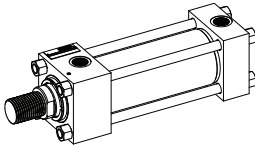
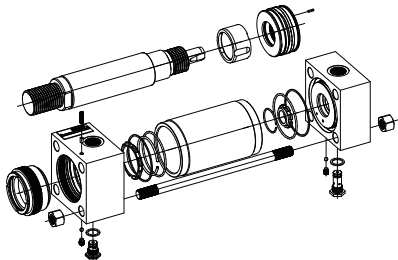

# Operating and maintenance norms for cylinders and servocylinders

These operating and maintenance norms are valid only for Atos hydraulic cylinders and are intended to provide useful information and to avoid risks when hydraulic cylinders are installed in a machine or a system. Information and notes on the transport and storage of hydraulic cylinders are also provided.

These norms must be strictly observed to avoid damages and ensure trouble-free operation. The respect of these operating and maintenance norms ensures an increased working life and thus reduced repairing cost of the hydraulic cylinders and system.

<p><b>Index</b></p> <ul style="list-style-type: none"> <li>1 SYMBOL CONVENTIONS</li> <li>2 GENERAL NOTES</li> <li>3 HARMONIZED STANDARDS</li> <li>4 WORKING CONDITIONS</li> <li>5 NAMEPLATES</li> <li>6 CE MARKING</li> <li>7 ATEX CERTIFICATION</li> <li>8 SAFETY NOTES</li> <li>9 MAINTENANCE</li> <li>10 TRANSPORT AND STORAGE</li> </ul>		
--	---	---

## 1 SYMBOLS CONVENTIONS



This symbol refers to additional notes mandatories for ATEX cylinders in potentially explosive atmospheres, see **tab. B400**



This symbol refers to possible danger which can cause serious injuries

## 2 GENERAL NOTES



**The cylinder operating instructions are a part of the operating instructions for the complete machine but they cannot replace it**



These operating instructions must always be kept near the machine where the cylinder is installed to ensure an easy and fast consultation

Atos is not liable for damages resulting from an incorrect observance of these instructions.

All the hydraulic cylinders have 1 year warranty; the expiration of warranty results from the following operations:

- Unauthorised mechanical or electronic interventions

- The hydraulic cylinders are not used exclusively for their intended purpose as defined in these operating and maintenance instructions

## 3 HARMONIZED STANDARDS

Hydraulic cylinders are manufactured in accordance with Directive 98/37/CE (Machine Directive) in the valid issue and associated technical rules. For an overall view relevant to application of the European directive in electrohydraulics, see **tab. P004**.



CKA cylinders meet the requirements laid down in the Explosion protection directive 94/9/CE with reference to European standards documentations:

- EN 13463-1 "Non electrical equipment for potentially explosive atmospheres - Basic method and requirements"
- EN 13463-5- c "Non electrical equipment for potentially explosive atmospheres - Protection by constructional safety"
- EN 13463-8- k "Non electrical equipment for potentially explosive atmospheres - Protection by liquid immersion"

The hydraulic cylinder must be exclusively used in areas and zones assigned to the equipment group and category. Also observe the other details about explosion protection given as follow. See section [7] for zones in relation to equipment groups and category.



**Check the code in the nameplate to ensure that the hydraulic cylinder is suitable for the installation area**

## 4 WORKING CONDITIONS



**The operation of hydraulic cylinders is not permitted at different operating and environmental conditions than those specified below**

Description	CK, CK', CH, CN	CC	CKA
Ambient temperature	-20 ÷ +120°C	-20 ÷ +120°C	-20 ÷ +70°C
Fluid temperature	-20 ÷ +120°C	-20 ÷ +120°C	-20 ÷ +70°C (T6)    -20 ÷ +120°C (T4) for seals type G2 (1)
Max surface temperature	-	-	≤ +85 °C (T6)    ≤ +135 °C (T4) for seals type G2 (1)
Max working pressure	16 MPa (160 bar)	25 MPa (160 bar)	16 MPa (160 bar)
Max pressure	25 MPa (250 bar)	32 MPa (320 bar)	25 MPa (250 bar)
Max frequency	5 Hz	5 Hz	5 Hz
Max speed	4 m/s		1 m/s    0,5 m/s for seals type G1
Recommended viscosity	15 ÷ 100 mm <sup>2</sup> /s		
Fluid contamination class according to ISO 4406	ISO 19/16 (achievable with in-line filters at 25 µm)		

**Note:** (1) Cylinders with seals type G2 may also be certified T6 limiting the max fluid temperature to 70°C

## 5 NAMEPLATES

**Nameplate 1 - Standard**

**Nameplate 2 - ATEX**

**Nameplate 1 - Standard (2)**

Pos.	Description
①	Delivery date
②	Cylinder code
③	Series number
④	Customer code (only if requested)
⑤	CE mark (see section 6)

**⊠ Nameplate 2 - ATEX (1)(2)**

Pos.	Description
①	Cylinder serial number
②	Marking according to ATEX directive
③	Working limit conditions
④	Notified body and certified number

**Working conditions - legend**

Sym.	Meaning
Tfmax	Max fluid temperature
Pmax	Max pressure
Tamb	Ambient temperature
fmax	Max frequency

**Notes:** (1) ATEX cylinders are supplied with 2 nameplates: standard and ATEX  
 (2) The position of the nameplate on the rear or front heads can change due to the cylinder overall dimensions

## 6 CE MARKING

Hydraulic cylinders are considered as pressure vessels and thus they are subject to the PED directive (97/23/CE), point 1.1 of article 3. Particularly they are designed to be used with fluids of group 2 (oil hydraulic fluids) and they have to be marked if the product  $P_{max} \times V$  (Volume under pressure) is higher than 10.000 bar x liter. Tables below show the minimum stroke over which the cylinders have to be CE marked. ATEX cylinders are CE marked according to ATEX directive (94/9/CE).

Cylinders CK, CH and CN - Pmax = 250 bar			
Bore [mm]	Rod [mm]	Stroke min [mm]	
		single rod	double rod
125	56	3255	4075
	70		4745
	90		5000
160	70	1985	2460
	90		2910
	110		3770
200	90	1270	1595
	140		2495
250	140	810	1185
320	180	495	725
400	220	315	455

Cylinders CC - Pmax = 320 bar			
Bore [mm]	Rod [mm]	Stroke min [mm]	
		single rod	double rod
100	70	3975	5000
125	90	2545	5000
140	90	2030	3455
160	110	1550	2945
180	110	1225	1960
200	140	990	1950
250	180	635	1320
320	220	385	735
400	280	245	485

## 7 ATEX CERTIFICATION

The user must define the overall areas of the system into different explosive atmospheres zones in accordance with directive 1999/92/CE. The table below shows the available installation zones related to the equipment group and category.

Equipment group to 94/9/CE	Category to 94/9/CE	Application, properties (excerpt from Directives)	Zones to 1999/92/CE
II	1G	Potentially explosive atmospheres, in which explosive gases, mists or vapors are likely to be present continuously, for long periods or frequently. <b>Very high level of protection</b>	0, 1, 2
II	2G	Potentially explosive atmospheres, in which explosive gases, mists or vapors are likely to occur occasionally. <b>High level of protection</b>	1, 2
II	3G	Potentially explosive atmospheres, in which explosive gases, mists or vapors are likely to occur for short periods. <b>Normal level of protection</b>	2
II	1D	Potentially explosive atmospheres, in which explosive dust/air mixtures are likely to be present continuously, for long periods or frequently. <b>Very high level of protection</b>	20, 21, 22
II	2D	Potentially explosive atmospheres, in which explosive dust/air mixtures are likely to occur occasionally. <b>High level of protection</b>	21, 22
II	3D	Potentially explosive atmospheres, in which explosive dust/air mixtures are likely to occur rarely or for short periods. <b>Normal level of protection</b>	22

**Note:** the permitted areas for the installation of Atos cylinders are keynoted in grey color

**!** The cylinder group and category may change when rod position transducers or proximity sensors are provided, see table below and tab. B400. For details about certification and safety notes consult the user's guides included in the supply

Cylinder type	Group	Equipment category	Gas group	Temperature class	Zone
CKA	II	2 GD	II C	T85°C(T6) / T135°C(T4)	1,2,21,22
CKA with ex-proof rod position transducer	II	GAS	II B	T6	1,2
		DUST	-	T85°C	22
CKA with ex-proof proximity sensors	II	3 G	II	T4	2

### Ex II 2GD ck IIC T85°C(T6)

#### GROUP II, ATEX certification

**Ex** = Equipment for explosive atmospheres

**II** = Group II for surface plants

**2** = High protection (equipment category)

**GD** = For gas, vapours and dust

**c,k** = Protection by constructional safety and by liquid immersion

**IIC** = Gas group

**T85°C / T135°C** = Surface temperature class for dust

**T6/T4** = Surface temperature class for gas

**Zone 1 (gas) and 21 (dust)** = Possibility of explosive atmospheres during normal functioning

**Zone 2 (gas) and 22 (dust)** = Low probability of explosive atmospheres

## 8 SAFETY NOTES

### 8.1 General

- The presence of cushioning can lead to a pick of pressure that can reduce the cylinder working life, ensure that the dissipated energy is less than the max value reported in **tab. B015**
- Make sure that the maximum working conditions, shown in section [4], are not exceeded
- Ensure to use hydraulic fluids compatible with the selected sealing system, see **tab. B137, B140, B160, B180, B241, B310 and B400**
- The rod must be handled with care to prevent damages on the surface coating which can deteriorate the sealing system and lead to the corrosion of the basic material
- The mounting screws must be free from shearing stress
- Transverse forces on the rods must always be avoided
- When the cylinder has to drive a rotating structure or where little alignment errors are expected, mounting style with spherical bearing should be used
- Contact surfaces, support elements in tolerance, elastic materials and labels must be covered before painting the cylinder

### 8.2 Proximity sensors

- Proximity sensors are supplied already adjusted, if other regulations are necessary see **tab. B137** or contact our technical office
- Ensure not to remove the sensor while the cylinder is under pressure
- The connectors must never be plugged or unplugged when the power supply is switched-on

### 8.3 Position measuring system

- Position transducers must never be removed, if not otherwise specified in **tab. B310**, while the cylinder is under pressure
- Observe the information provided in **tab. B310** for the electronic connections
- The connectors must never be plugged or unplugged when the power supply is switched-on

### 8.4 Installation

- Consult **tab. P002** for installation, commissioning and maintenance of electrohydraulic system
- The piping have to be dimensioned according to the max pressure and max flow rate required
- All pipes and surfaces must be cleaned from dirt before mounting
- Remove all plug screws and covers before mounting
- Make sure that connections are sealed before giving pressure to the system
- Ensure to not exchange the pipe ports when connecting the cylinders
- Bleed-off the system or the hydraulic cylinder
- Ensure that the cylinder mounting allow easy of acces for the purpose of maintenance and the adjustment of cushioning



- The max surface temperature indicated in the nameplate must be lower than the following values:

**GAS - 80% of gas ignition temperature**

**DUST - max value between dust ignition temperature - 75°C and 2/3 of dust ignition temperature**

- The ignition temperature of the fluid must be 50°C greater than the maximum surface temperature indicated in the nameplate

- The cylinder must be grounded using the threaded hole on the rear head, evidenced by the nameplate with ground symbol. The hydraulic cylinder must be put at the same electric potential of the machine



**For details about ex-proof proximity sensors or position transducer refer to the user's guide included in the supply**

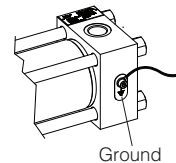

## 9 MAINTENANCE



**Maintenance must be carried out only by qualified personnel with a specific knowledge of hydraulics and electrohydraulics**

### 9.1 Preliminary check and ordinary maintenance

Atos hydraulic cylinders don't require any maintenance after commissioning. Anyway it is recommended to take into account the following remarks:

- Results of maintenance and inspection must be planned and documented
- Check oil escaping from oil ports or leakages at the cylinder heads
- Check for damages of the chromeplated surface of the rod: damages may indicate oil contamination or the presence of excessive transverse load
- Determine lubricating intervals for spherical clevises, trunnion and all parts not self-lubricated
- The rod should always be retracted during long stop of the machine or system
- Remove any salt, machining residuals or other dirt cumulated on the rod surface
- Follow the maintenance instructions of the fluid manufacturer



- Any planned maintenance must be performed only by experienced personnel, authorized by Atos

- Ordinary maintenance of the cylinder consist of cleaning of the external surfaces using a wet cloth to avoid accumulation of dust layer > 5 mm

- Do not use compressed air for cleaning to avoid any dangerous dust dispersion on the surrounding atmosphere

- Any sudden increment in temperature requires immediate stop of the system and inspection of the relevant components

### 9.2 Repairing

Before beginning any repairing observe the following guidelines:

- Unauthorized opening of the cylinder during the warranty period results in the warranty expiration
- Be sure to use only original spare parts manufactured or supplied by Atos
- Provide all the required tools to make the repair operations safely and not damage the components
- Read and follow all the safety notes given in section [8]
- Ensure that the cylinder is well locked before beginning any operation
- Disassembly or assembly the cylinder with the right order as indicated in section **9.3**
- When mounting rod or piston guides and seals observe the correct position as indicated in section **9.4**. Any bad positioning can result in oil leakages
- It is strongly recommended the use of expanding sleeves to insert the seals in the proper groove
- Tighten all the screws or nuts as follow: lubricates the threads, insert the screw or the nut by hand for some turns, tighten the screw crosswise with the tightening torque specified in the technical table (a pneumatic screw driver may be used)
- Rod bearing and piston must be locked respectively to the front head and to the rod by means of special pin to avoid unscrewing
- The replacement of wear parts such as seals, rod bearing and guide rings depends on the operating conditions, temperature and quality of the fluid



Any repairing must be performed only by experienced personnel, authorized by Atos

### 9.3 Cylinders exploded views

**CK, CKA** - For spare parts see **tab. KTR-B137**

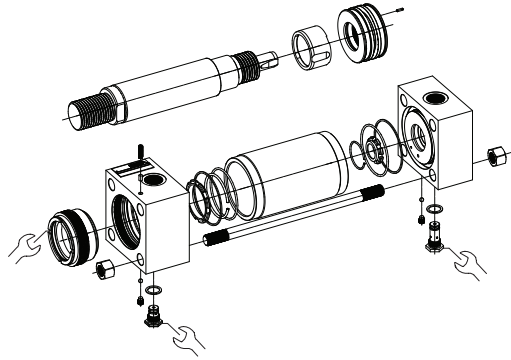

**CH** - For spare parts see **tab. KTR-B140 and KTR-B160**

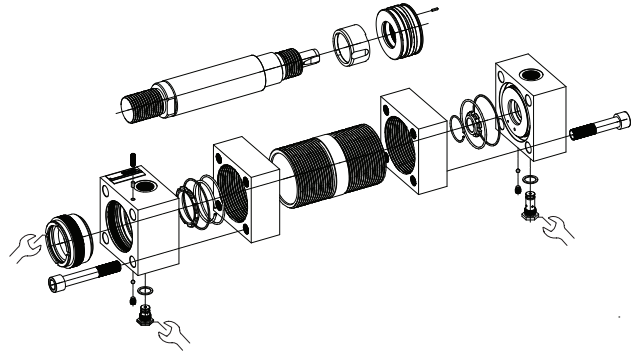

**CN** - For spare parts see **tab. KTR-B180**

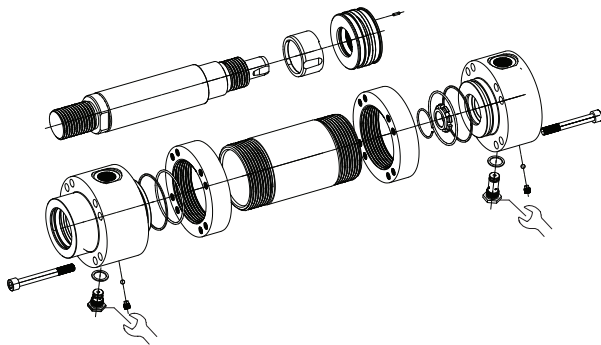

**CC** - For spare parts see **tab. KTR-B241**

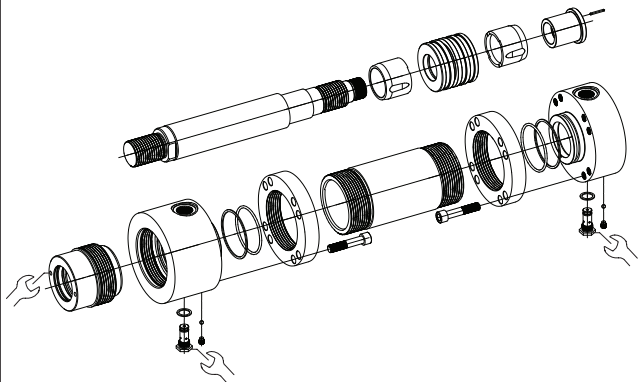

**Note:** this symbol means that a particular equipment is required for mounting, contact our technical office

### 9.4 Sealing system mounting

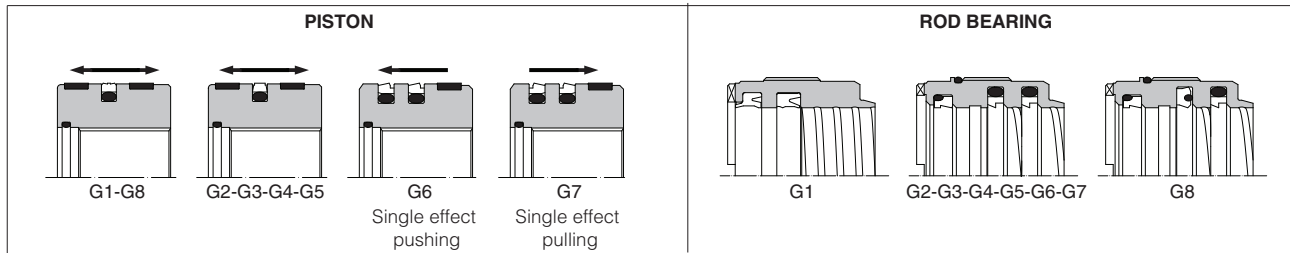

## 10 TRANSPORT AND STORAGE

### 10.1 Transport

Observe the following guidelines for transport of hydraulic cylinders:

- Cylinders have to be transported using a forklift truck or a lifting gear always ensuring a stable position of the cylinder
- Cylinders have to be transported in horizontal position in their original packaging
- Use soft lifting belts to move or lift the cylinders in order to avoid damages
- Before any movement check the cylinders weight (due to tolerances, the weight may be 10% greater than the values specified in the technical table)

**⚠ Additional parts such as pipes, subplates and transducers must never be used for lifting**

### 10.2 Storage

Corrosion protection is achieved with epoxy coatings: the primer grants a storage period up to 12 months. Additionally all cylinders are tested with mineral oil OSO 46; the oil film, presents in the cylinder chambers after testing, ensures the internal corrosion protection.

Anyway be care to observe the following remarks:

- When a storage in the open air is foreseen ensure that cylinders are well protected against water
- The cylinders must be inspected at least once a year and rotated through 90° every six months to preserve the seals

**⚠ In case of storage period longer than 12 months, contact our technical office**