

Flow control valves type QV-10, QV-20

pressure compensated, two or three way, ISO 6263 sizes 10 and 20

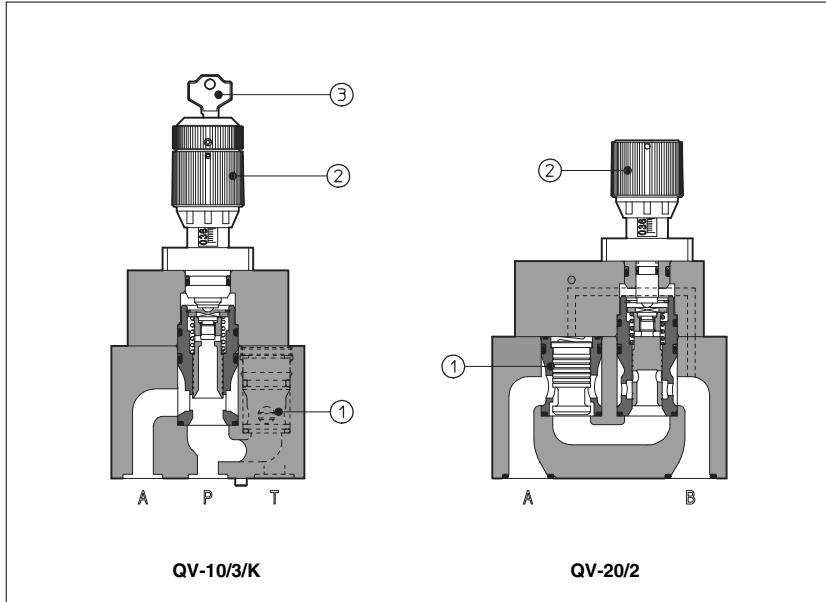

QV are flow control valves with pressure compensator ① (the controlled flow rate is independent of pressure variations), designed to operate in oil hydraulic systems.

The two-way type are available with a built-in check valve to allow the free flow in the opposite direction.

The flow adjustment is done by turning a graduate micrometer knob ②. Clockwise rotation increases the flow regulation. Optional versions with locking key ③ on the adjustment knob are available on request.

QV-10 = ISO 6263 size 10 interface: max flow 60 l/min, max pressure 250 bar.

QV-20 = ISO 6263 size 20 interface: flow up to 180 l/min (three-way version), max pressure 250 bar.

1 MODEL CODE

QV	-	10	/	3	/	K	**	/	*
Pressure compensated flow control valve		Size: 10 20		Options: /K = with lock key for the setting knob only for two-way valves /V = without by-pass check valve		Series number		Synthetic fluids: WG = water-glycol PE = phosphate ester	

2 HYDRAULIC CHARACTERISTICS

Hydraulic symbols

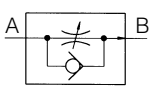

TWO-WAY VERSION

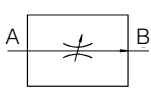

TWO-WAY VERSION WITHOUT CHECK VALVE

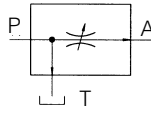

THREE-WAY VERSION

Valve model	QV-10/2	QV-10/2/V	QV-10/3	QV-20/2	QV-20/2/V	QV-20/3
Max regulated flow [l/min]	65	60		130	160	180
Min regulated flow [cm³/min]	120			120		
Max flow B → A through check valve (2-way versions) [l/min]	80	-	-	160	-	-
Regulating Δp [bar]	6		6	7		8
Max flow on port P (only 3-way versions) [l/min]	-	-	60	-	-	180
Max pressure [bar]	250			250		

3 MAIN CHARACTERISTICS OF FLOW CONTROL VALVES TYPE QV-10 AND QV-20

Assembly position	Any position
Subplate surface finishing	Roughness index $\sqrt{0.4}$, flatness ratio 0,01/100 (ISO 1101)
Ambient temperature	-20°C to + 70°
Fluid	Hydraulic oil as per DIN 51524...535, for other fluids see section 1
Recommended viscosity	15 ÷ 100 mm ² /s at 40°C (ISO VG 15 ÷ 100)
Fluid contamination class	ISO 19/16, achieved with in line filters at 25 µm value and $\beta_{25} \geq 75$ (recommended)
Fluid temperature	-20°C +60°C (standard and /WG seals) -20°C +80°C (/PE seals)

4 DIAGRAMS OF QV-10 based on mineral oil ISO VG 46 at 50°C

4.1 Regulation diagram

- 1 = QV-10/2
- 2 = QV-10/2N
- 3 = QV-10/3 with 60 l/min of inlet flow
- 4 = QV-10/3 with 30 l/min of inlet flow

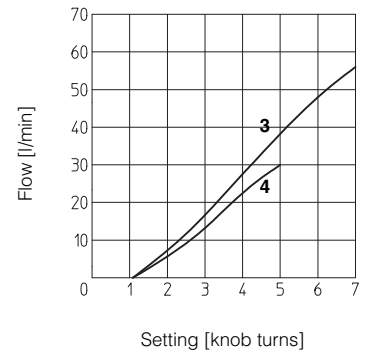
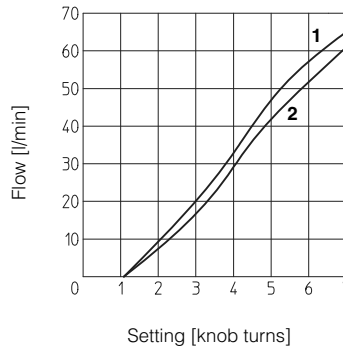

4.2 Q/Δp diagram through the check valve for free flow B → A (two-way valve)

- 5 = QV-10/2

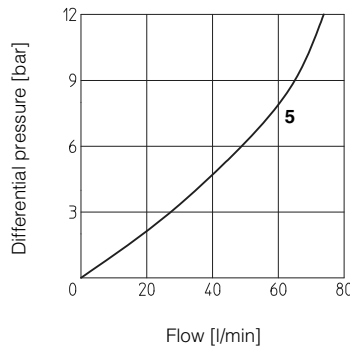

5 DIAGRAMS OF QV-20 based on mineral oil ISO VG 46 at 50°C

5.1 Regulation diagram

- 1 = QV-20/2
- 2 = QV-20/2N
- 3 = QV-20/3 with 180 l/min of inlet flow
- 4 = QV-20/3 with 90 l/min of inlet flow

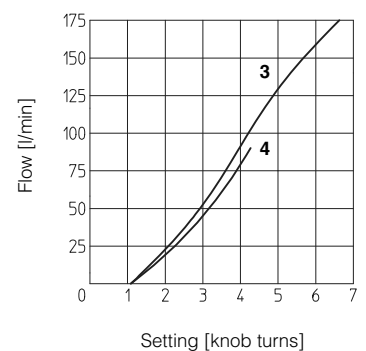
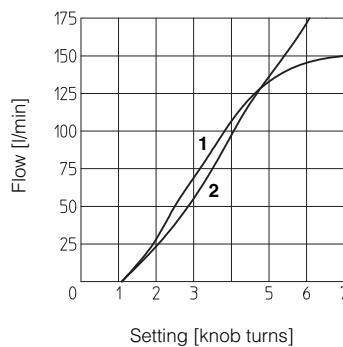

5.2 Q/Δp diagram through the check valve for free flow B → A (two-way valve)

- 5 = QV-20/2

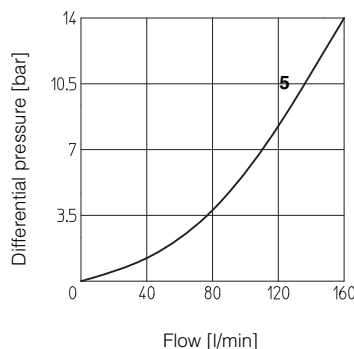

6 DIMENSIONS OF QV-10 [mm]

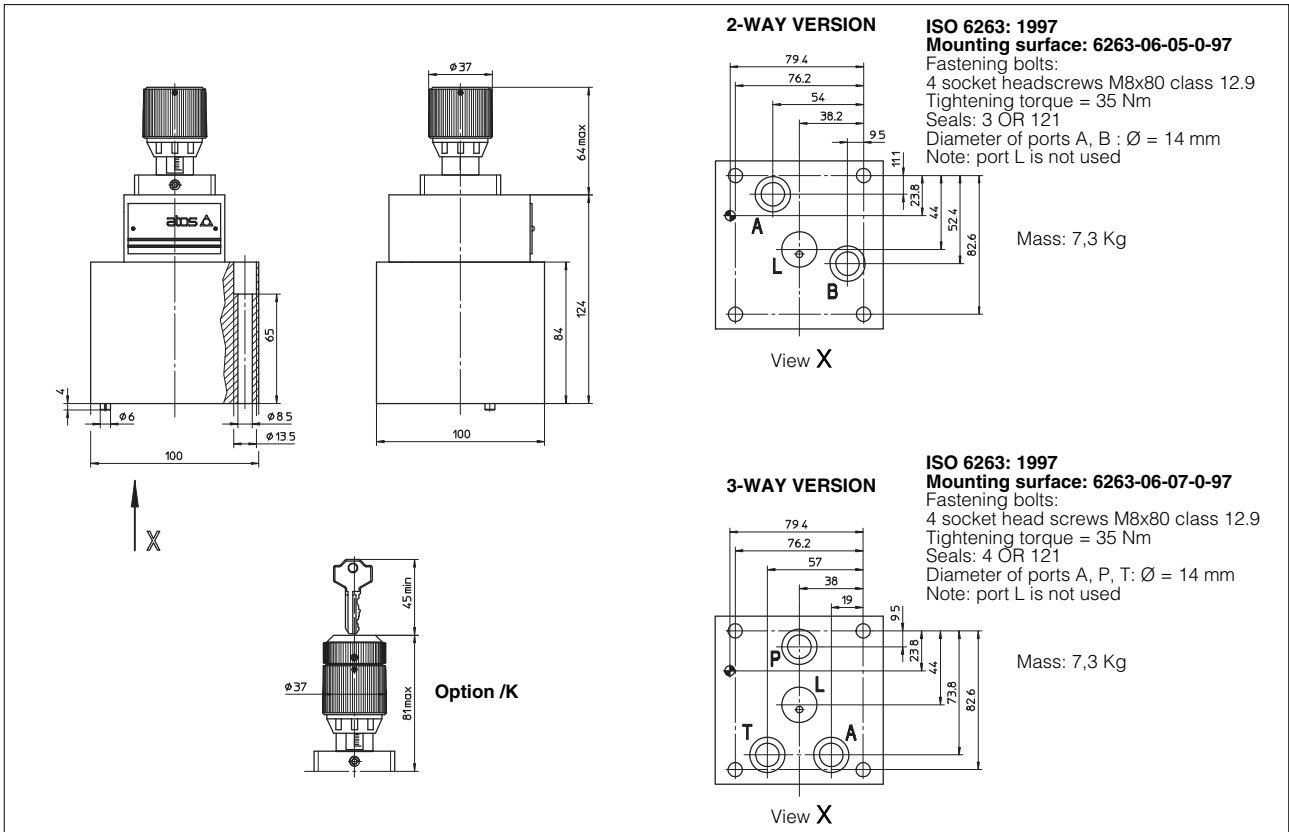

7 DIMENSIONS OF QV-20 [mm]

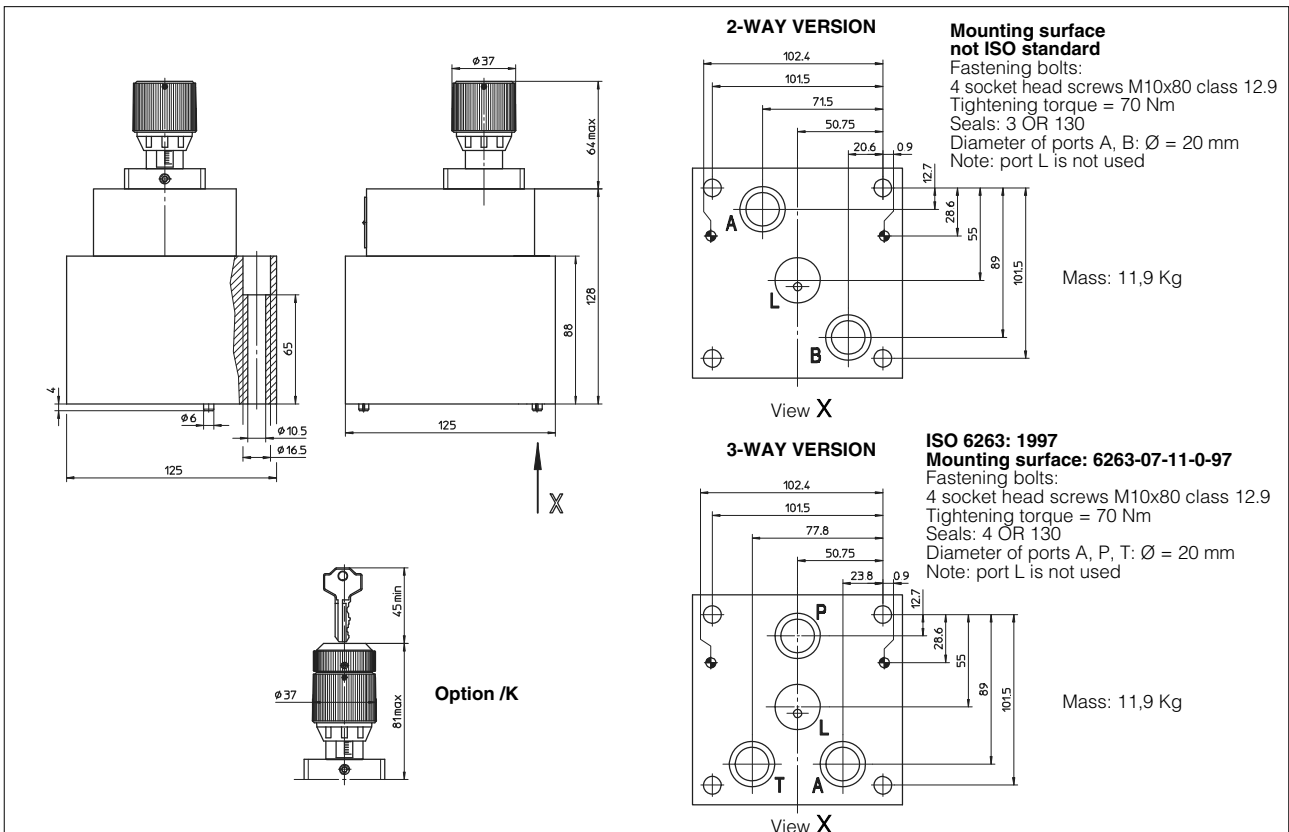

8 MOUNTING SUBPLATES

Valve	Subplate model	Port location	Ports A, B, P, T	\varnothing Counterbore [mm] A, B, P, T	Mass [Kg]
QV-10/2	BA-320	Ports A, B, underneath;	G 1/2"	30	4,2
QV-10/3	BA-322	Ports A, P, T, underneath;	G 1/2"	30	3,9
QV-20/2	BA-520	Ports A,B, underneath;	G 1"	46	5,5
QV-20/3	BA-522	Ports A, P, T, underneath;	G 1"	46	5,2

The subplates are supplied with fastening bolts. For further details see table K280.