

Modular sequence valves type HS-011 and KS-011

spool type, ISO 4401 size 06 and 10

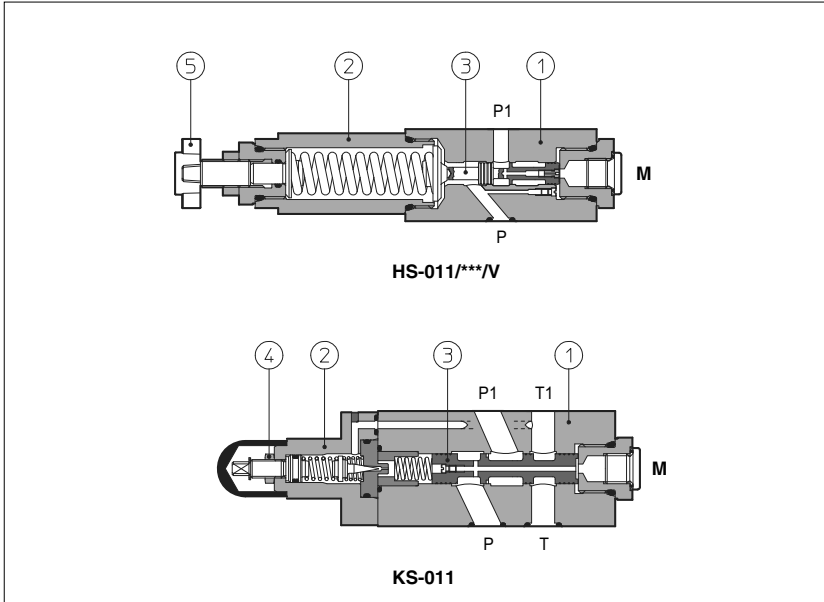

HS are direct sequence valves, spool type ③.
KS are double stage ① ② sequence valves, spool type ③.

Pressure adjustment is operated by loosening the locking nut ④ and turning the setting screw in the normal model.

Optional versions with a handwheel ⑤ are available on request.
Clockwise rotation increases the pressure.

HS = ISO 4401 size 06 interface: flow up to 40 l/min, pressure up to 210 bar.

KS = ISO 4401 size 10 interface: flow up to 80 l/min, pressure up to 210 bar.

Valves designed to operate in hydraulic systems with hydraulic mineral oil or synthetic fluid having similar lubricating characteristics.

1 MODEL CODE

HS	-	011	/	210	/V	**	/*
Modular sequence valve, size: HS = 06 KS = 10							Synthetic fluids: WG = water-glycol PE = phosphate ester
Configuration, see section 2 011 = single, acting on port P, drain to port T						Series number	
Pressure range: for HS: 32 = 3 - 32 bar 100 = 20 - 100 bar 210 = 50 - 210 bar for KS: 100 = 7 - 100 bar 210 = 8 - 210 bar					Options: /V = setting adjustment by handwheel instead of a grub screw protected by cap Only for HS: /VF = regulating knob /VS = regulating knob with safety locking		

2 HYDRAULIC CHARACTERISTICS

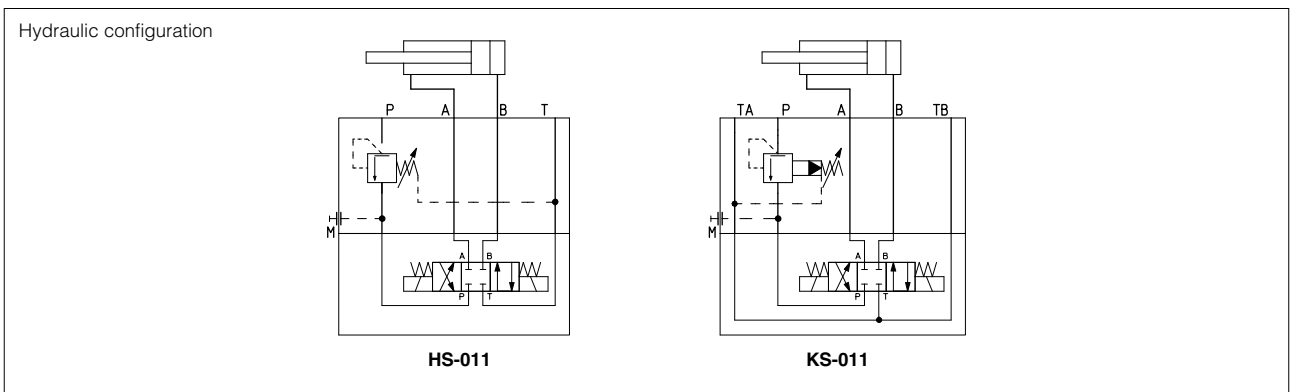

Valve model	HS-011/32	HS-011/100	HS-011/210	KS-011/100	KS-011/210
Max flow [l/min]		40			80
Max drain [cm ³ /min]		50			50
Pressure range [bar]	3 - 32	20 - 100	50 - 210	7 - 100	8 - 210
Max inlet pressure [bar]		350			315
Max pressure on port T [bar]		160			160

3 MAIN CHARACTERISTICS OF MODULAR SEQUENCE VALVES TYPE HS, KS

Assembly position	Any position
Subplate surface finishing	Roughness index $\sqrt{0.4}$; flatness ratio 0,01/100 (ISO 1101)
Ambient temperature	-20°C to + 70°
Fluid	Hydraulic oil as per DIN 51524...535, for other fluids see section I
Recommended viscosity	15 ÷ 100 mm ² /s at 40°C (ISO VG 15 ÷ 100)
Fluid contamination class	ISO 19/16, achieved with in line filters at 25 µm value and $\beta_{25} \geq 75$ (recommended)
Fluid temperature	-20°C +60°C (standard and /WG seals) -20°C +80°C (/PE seals)

4 REGULATED PRESSURE VERSUS FLOW DIAGRAMS based on mineral oil ISO VG 46 at 50°C

1 = HS
2 = KS

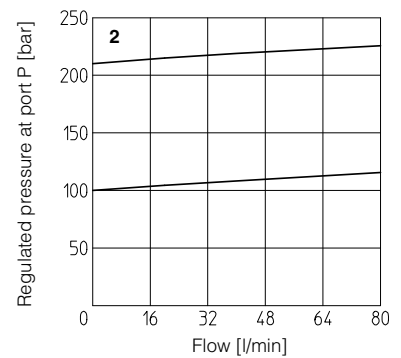
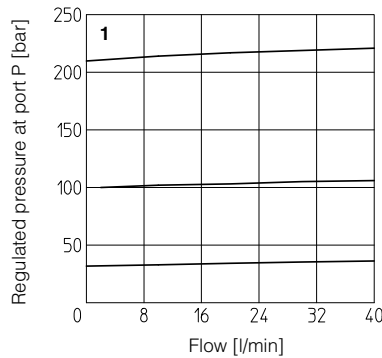

5 INSTALLATION DIMENSIONS [mm]

HS-011

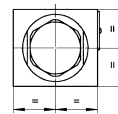
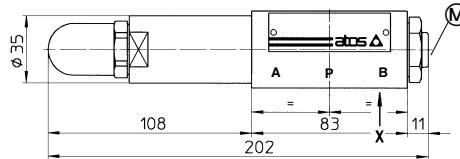
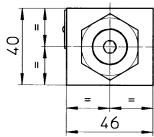

(M) = Pressure gauge port = G 1/4"

Adjustment device for option/V

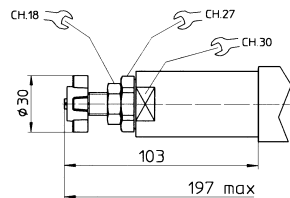

ISO 4401: 2005

Mounting surface: 4401-03-02-0-05

Diameter of ports A, B, P, T: Ø = 7,5 mm
Seals: 4 OR 108

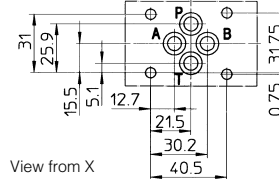

View from X

Adjustment device for option /VF and /VS

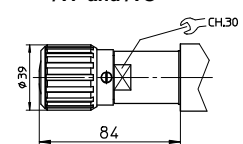

Fastening bolts: n°4 socket head screws M5. The length depends on number and type of modular elements associated.

Mass: 2 Kg

KS-011

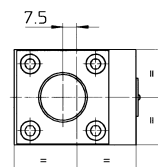
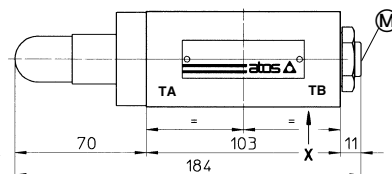
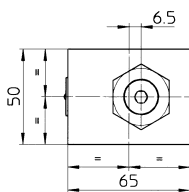

(M) = Pressure gauge port = G 1/4"

Adjustment device for option/V

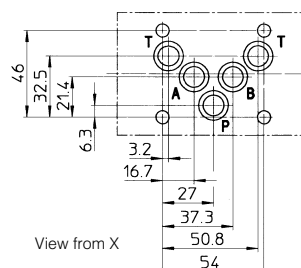
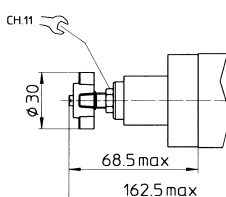

View from X

ISO 4401: 2005

Mounting surface: 4401-05-04-0-05

Diameter of ports A, B, P, T: Ø = 11,2 mm
Seals: 5 OR 2050

Fastening bolts: n°4 socket head screws M6. The length depends on number and type of modular elements associated.

Mass: 3 Kg