

Proportional reducing valves type AGRCZO-A*

two stages, normally closed, without integral pressure transducer, ISO 5781 size 10 and 20

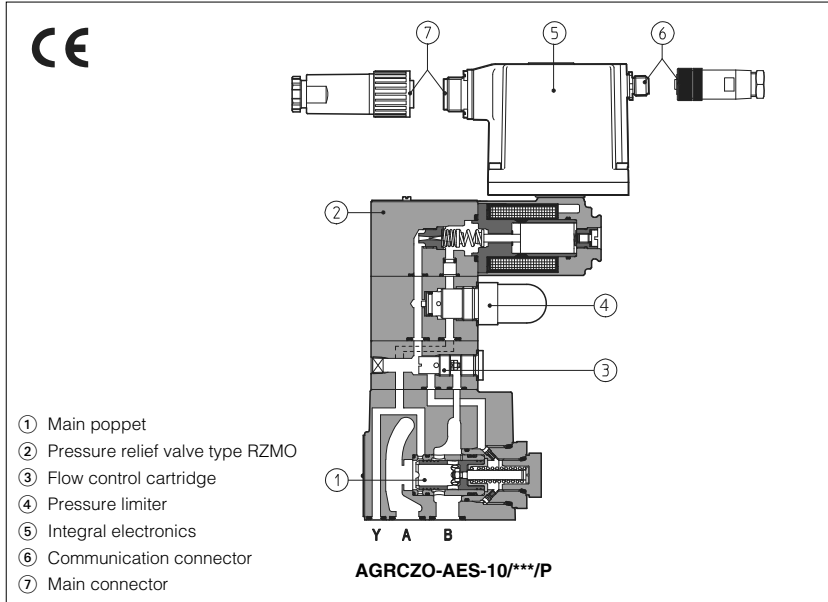

1 MODEL CODE

AGRCZO		- AES	- PS	- 10	/ 315	/ *	**	/	*
Proportional pressure reducing valve									Synthetic fluids WG = water-glycol PE = phosphate ester
A = without integral transducer AE = as A plus integral electronics AES = as A plus integral digital electronics									Series number
Communication interfaces (only for AES)									
PS = Serial BC = CANopen BP = PROFIBUS DP									
Size: 10, 20									
Pressure range									
50 = 50 bar 100 = 100 bar 210 = 210 bar 315 = 315 bar									
									Hydraulic options: P = with integral mechanical pressure limiter R = with check valve for free reverse flow Options for -A execution, see section 15: 6 = with 6 V _{DC} coil instead of standard 12V _{DC} coil 18 = with 18 V _{DC} coil instead of standard 12V _{DC} coil Electronics options for -AE execution, see section 17: I = current reference (4÷20 mA) Q = enable signal Electronics options for -AES execution, see section 17: I = current reference 4÷20 mA Z = double power supply, enable fault and monitor (12 pin connector)

AGRCZO are two-stage normally closed proportional pressure reducing valves without integral pressure transducer, which provide pressure regulation proportional to electronic reference signal.

They operate in association with electronic drivers, see table 2 which supply the proportional valve with proper current signal to align valve regulation to the reference signal supplied to the electronic driver.

They are available in different executions:

- -A, without integral pressure transducer.
- -AE, -AES, as -A plus analogue (AE) or digital (AES) integral electronics 5.

The piloting pressure to the poppet 1 is modulated by a proportional pressure relief valve type RZMO 2, see tab. F007.

A modular pressure compensated flow control cartridge 3 assures constant pilot flow and therefore high pressure stability.

The integral electronics 5 ensures factory presetting, fine functionality plus valve-to-valve interchangeability and simplified wiring and installation.

The electronic main connector 7 is fully interchangeable for -AE and -AES executions. Standard 7 pin connector is used for power supply, analog input reference and monitor signals.

12 pin connector is used option /Z (AES).

Following communication interfaces 4 are available for the digital -AES execution:

- -PS, Serial communication interface. The valve reference signal is provided with analogue commands
- -BC, CANopen interface
- -BP, PROFIBUS DP interface

The valves with -BC and -BP interfaces can be integrated into a fieldbus communication network and thus digitally operated by the machine control unit.

The coils are fully plastic encapsulated (insulation class H), and the valves have antivibration, antishock and weather-proof features.

Surface mounting: ISO 5781 size 10 and 20.
Max flow: 160, 300 l/min respectively
Max pressure: 315 bar.

2 ELECTRONIC DRIVERS FOR AGRCZO

Valve model	-A						-AE	-AES
	E-MI-AC-01F	E-MI-AS-IR	E-BM-AC-01F	E-BM-AS-PS	E-ME-AC-01F	E-RP-AC-01F		
Drivers model	E-MI-AC-01F	E-MI-AS-IR	E-BM-AC-01F	E-BM-AS-PS	E-ME-AC-01F	E-RP-AC-01F	E-RI-AE	E-RI-AES
Data sheet	G010	G020	G025	G030	G035	G100	G110	G115

Note: for power supply and communication connector see section 15

3 HYDRAULIC CHARACTERISTICS (based on mineral oil ISO VG 46 at 50 °C)

Hydraulic symbols	AGRCZO-A, AGRCZO-A*/R		AGRCZO-AE, -AES, AGRCZO-AE*/R, -AES/R	
	10	20	10	20
Size	10	20	10	20
Max regulated pressure (Q = 10 l/min) [bar]	50; 100; 210; 315			
Min regulated pressure at port A [bar]	1			
Max pressure at port B [bar]	315			
Max pressure at port A [bar]	315			
Max flow [l/min]	160	300	160	300
Response time 0 - 100% step signal (depending on installation) [ms]	50	60	50	60
Hysteresis [% of the max pressure]	≤ 2			
Linearity [% of the max pressure]	≤ 3			
Repeatability [% of the max pressure]	≤ 2			

Above performance data refer to valves coupled with Atos electronic drivers, see section 2.

4 GENERAL NOTES

AGRCZO proportional valves are CE marked according to the applicable Directives (e.g. Immunity/Emission EMC Directive).

Installation, wirings and start-up procedures must be performed according to the general prescriptions shown in table F003 and in the installation notes supplied with relevant components.

The electrical signals of the valve (e.g. monitor signals) must not be directly used to activate safety functions, like to switch-ON/OFF the machine's safety components, as prescribed by the European standards (Safety requirements of fluid technology systems and components-hydraulics, EN-892).

5 OPTIONS FOR -A EXECUTION

5.1 Option /6 6 Vdc coil instead of standard 12 Vdc, to be used in case of power supply 12 Vdc

5.2 Option /18 18 Vdc coil instead of standard 12 Vdc, to be used with electronic drivers not supplied by Atos

6 CONNECTIONS FOR -A EXECUTION

SOLENOID POWER SUPPLY CONNECTOR	
PIN	Signal description
1	SUPPLY
2	SUPPLY
3	GND

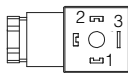

7 ANALOG INTEGRAL DRIVERS -AE - OPTIONS

Standard driver execution provides on the 7 pin main connector:

Power supply - 24Vdc must be appropriately stabilized or rectified and filtered; a 2,5 A safety fuse is required in series to the driver power supply. Apply at least a 10000 µF/40 V capacitance to single phase rectifiers or a 4700 µF/40 V capacitance to three phase rectifiers

Reference input signal - analog differential input with 0÷+10Vdc nominal range (pin D,E), proportional to desired coil current

Monitor output signal - analog output signal proportional to the actual valve's coil current (1V monitor = 1A coil current)

Following options are available to adapt standard execution to special application requirements:

7.1 Option /I

It provides the 4±20 mA current reference signal instead of the standard 0÷+10 Vdc. Monitor output signal is still the standard 0÷+10Vdc.

It is normally used in case of long distance between the machine control unit and the valve or where the reference signal can be affected by electrical noise; the valve functioning is disabled in case of reference signal cable breakage.

7.2 Option /Q

It provides the possibility to enable or disable the valve functioning without cutting the power supply (the valve functioning is disabled but the driver current output stage is still active). To enable the driver supply a 24Vdc on the enable input signal.

7.3 Possible combined option: /IQ

8 DIGITAL INTEGRAL DRIVERS -AE - MAIN FUNCTIONS AND ELECTRONIC CONNECTIONS

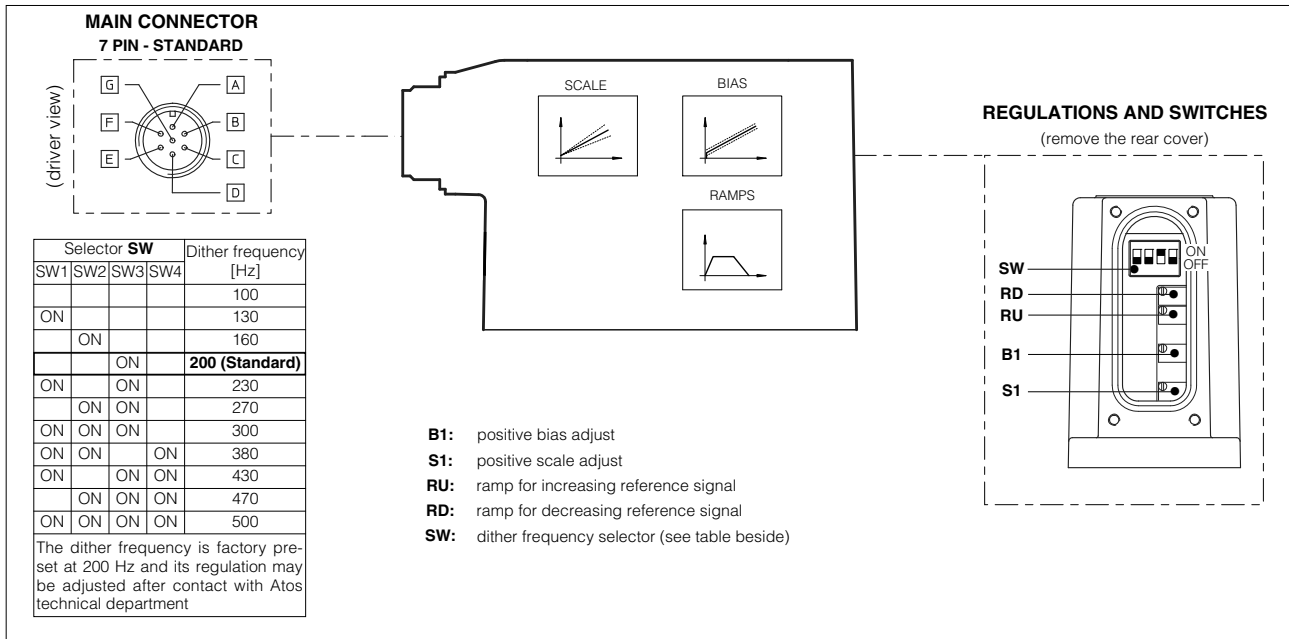

8.1 ELECTRONIC CONNECTIONS - 7 PIN MAIN CONNECTORS

PIN	SIGNAL	TECHNICAL SPECIFICATIONS	NOTES
A	V+	Power supply 24 Vdc for solenoid power stage and driver logic	Input - power supply
B	V0	Power supply 0 Vdc for solenoid power stage and driver logic	Gnd - power supply
C ⁽¹⁾	AGND	Ground - signal zero for MONITOR signal	Gnd - analog signal
	ENABLE	Enable (24 Vdc) or disable (0 Vdc) the driver (for /Q option)	Input - on/off signal
D	INPUT+	Reference analog input: 0÷+10 Vdc maximum range (4 ÷ 20 mA for /I option)	Input - analog signal
E	INPUT -	Normal working range 0÷+10 Vdc (4 ÷ 20 mA for /I option)	
F	MONITOR	Monitor analog output: 0÷+10 Vdc maximum range	Output - analog signal
G	EARTH	Internally connected to the driver housing	

Note: (1) with /Q option ENABLE signal replaces AGND on pin C; MONITOR signal is referred to pin B.

A minimum time of 60ms to 160ms have to be considered between the driver energizing with the 24 Vdc power supply and when the valve is ready to operate. During this time the current to the valve coils is switched to zero

9 DIGITAL INTEGRAL DRIVERS -AES - OPTIONS

Standard driver execution provides on the 7 pin main connector:

Power supply - 24Vdc must be appropriately stabilized or rectified and filtered; a 2,5 A safety fuse is required in series to each driver power supply. Apply at least a 10000 µF/40 V capacitance to single phase rectifiers or a 4700 µF/40 V capacitance to three phase rectifiers.

Reference input signal - analog differential input with 0÷+10 Vdc nominal range (pin D,E), proportional to desired coil current

Monitor output signal - analog output signal proportional to the actual valve's coil current (1V monitor = 1A coil current)

Following options are available to adapt standard execution to special application requirements:

9.1 Option /I

It provides 4÷20 mA current reference signal instead of the standard 0÷+10 Vdc. Monitor output signal is still the standard 0÷+10 Vdc

It is normally used in case of long distance between the machine control unit and the valve or where the reference signal can be affected by electrical noise; the valve functioning is disabled in case of reference signal cable breakage.

9.2 Option /Z

It provides on a 12 pin main connector the above standard features plus:

Logic power supply

Option /Z provides separate power supply for the solenoid (pin 1, 2) and for the digital electronic circuits (pin 9, 10).

Cutting solenoid power supply allows to interrupt the valve functioning but keeping energized the digital electronics thus avoiding fault conditions of the machine fieldbus controller. This condition allows to realize safety systems in compliance with European Norms EN13849-1 (ex EN954-1).

Enable Input Signal

To enable the driver, supply a 24Vdc on pin 3 referred to pin 2: when the Enable signal is set to zero the valve functioning is disabled (zero current to the solenoid) but the driver current output stage is still active. This condition does not comply with European Norms EN13849-1 (ex EN954-1).

Fault Output Signal

Fault output signal indicates fault conditions of the driver (solenoid short circuits/not connected, reference signal cable broken for 4÷20mA input, etc.). Fault presence corresponds to 0 Vdc, normal working corresponds to 24Vdc (pin 11 referred to pin 2): Fault status is not affected by the Enable input signal.

9.3 Possible combined option: /IZ

10 DIGITAL INTEGRAL DRIVERS -AES - MAIN FUNCTIONS AND ELECTRONIC CONNECTIONS

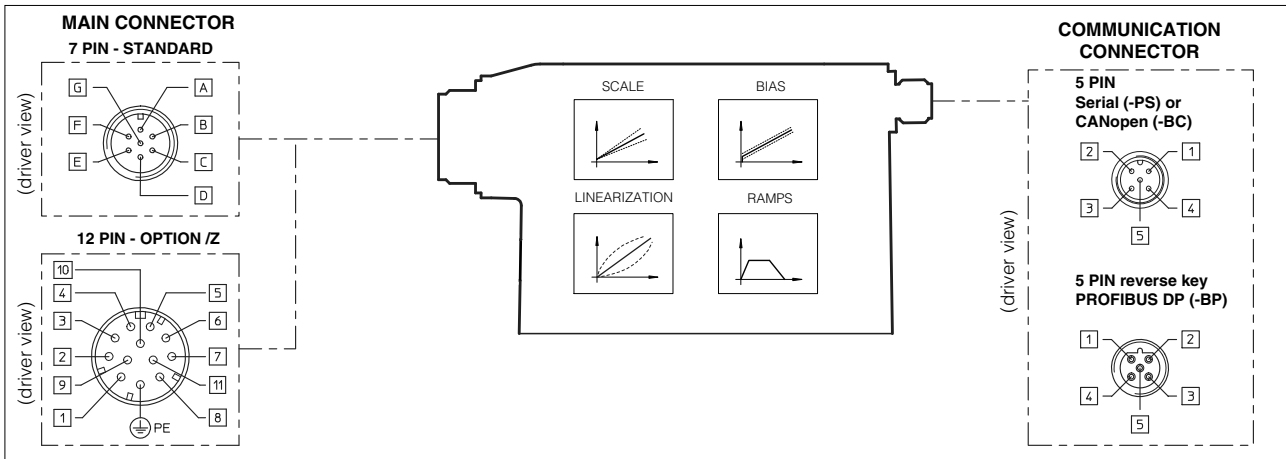

10.1 ELECTRONIC CONNECTIONS - 7 & 12 PIN MAIN CONNECTORS

Standard 7pin	/Z option 12pin	SIGNAL	TECHNICAL SPECIFICATIONS	NOTES
A	1	V+	Power supply 24 Vdc for solenoid power stage (and for driver logic on 7 pin connection)	Input - power supply
B	2	V0	Power supply 0 Vdc for solenoid power stage (and for driver logic on 7 pin connection)	Gnd - power supply
-	3	ENABLE	Enable (24 Vdc) or disable (0 Vdc) the driver	Input - on/off signal
D	4	INPUT+	Reference analog input: ± 10 Vdc maximum range ($4 \div 20$ mA for /I option)	Input - analog signal
E	-	INPUT -	Normal working range $0 \div +10$ Vdc ($4 \div 20$ mA for /I option) standard: differential input; /Z option: common mode INPUT+ referred to AGND	
C	5	AGND	Ground - signal zero for MONITOR signal signal zero for INPUT+ signal (only for /Z option)	Gnd - analog signal
F	6	MONITOR	Monitor analog output: $0 \div +10$ Vdc maximum range	Output - analog signal
-	7	NC	do not connect	
-	8	NC	do not connect	
-	9	VL+	Power supply 24 Vdc for driver logic	Input - power supply
-	10	VLO	Power supply 0 Vdc for driver logic	Gnd - power supply
-	11	FAULT	Fault (0 Vdc) or normal working (24 Vdc)	Output - on/off signal
G	PE	EARTH	Internally connected to the driver housing	

Note: A minimum time of 270 to 340 ms have be considered between the driver energizing with the 24Vdc power supply and when the valve is ready to operate. During this time the current to the valve coils is switched to zero.

10.2 ELECTRONIC CONNECTIONS - 5 PIN COMMUNICATION CONNECTORS

PIN	-PS Serial		-BC CANopen		-BP PROFIBUS DP	
	SIGNAL	TECHNICAL SPECIFICATION	SIGNAL	TECHNICAL SPECIFICATION	SIGNAL	TECHNICAL SPECIFICATION
1	NC	do not connect	CAN_SHLD	Shield	+5V	for termination
2	NC	do not connect	NC	do not connect	LINE-A	Bus line (high)
3	RS_GND	Signal zero data line	CAN_GND	Signal zero data line	DGND	data line and termination Signal zero
4	RS_RX	Valves receiving data line	CAN_H	Bus line (high)	LINE-B	Bus line (low)
5	RS_TX	Valves transmitting data line	CAN_L	Bus line (low)	SHIELD	

11 SOFTWARE TOOLS

The functional parameters of digital valves, as the bias, scale ramp and linearization of the regulation characteristic, can be easily set and optimized with the Atos E-SW programming software, available in three different versions according to the driver's communication interfacing: E-SW-PS (Serial), E-SW-BC (CANopen) and E-SW-BP (PROFIBUS DP).

A proper connection is required between the PC and the electronic driver communication port: for a more detailed description of software interface, PC requirements, adapters, cables and terminators, please see table G500.

Proportional valves with fieldbus communication interface (-BC and -BP) can be directly managed by the machine control unit; it is required to implement in the machine control the standard communication as described in the user manuals supplied with the relevant programming software. For detailed description of available fieldbus feature, see table G510.

On first supply of the E-SW software, it is required to apply for the registration in the Atos download area: www.download.atos.com

Once the registration is completed, the password will be sent by email.

The software remains active for 10 days from the installation date and then it stops until the user inputs his password.

With the password you can also download, in your personal area, the latest releases of the Atos software, manuals, drivers and configuration files.

12 MAIN CHARACTERISTICS OF PROPORTIONAL PRESSURE REDUCING VALVES TYPE AGRCZO

Assembly position	Any position
Subplate surface finishing	Roughness index, $\sqrt{0.4}$ flatness ratio 0,01/100 (ISO 1101)
Ambient temperature	$-20^{\circ}\text{C} \div +70^{\circ}\text{C}$ for -A execution; $-20^{\circ}\text{C} \div +60^{\circ}\text{C}$ for -AE and -AES executions
Fluid	Hydraulic oil as per DIN 51524 ... 535 for other fluids see section 11
Recommended viscosity	$15 \div 100$ mm ² /s at 40°C (ISO VG 15÷100)
Fluid contamination class	ISO 18/15 achieved with in line filters of 10 μm and $\beta_{10} \geq 75$ (recommended)
Fluid temperature	$-20^{\circ}\text{C} +60^{\circ}\text{C}$ (standard and WG seals) $-20^{\circ}\text{C} +80^{\circ}\text{C}$ (PE seals)
Coil resistance R at 20°C	$3 \div 3.3 \Omega$ for standard 12 Vdc coil; $2 \div 2.2 \Omega$ for 6 Vdc coil; $13 \div 13.4 \Omega$ for 18 Vdc coil
Max solenoid current	2,6 A for standard 12 Vdc coil; 3,25 A for 6 Vdc coil; 1,5 A for 18 Vdc coil
Max power	40 Watt
Protection degree (CEI EN-60529)	IP65 for -A execution; IP65÷67 for -AE and AES executions, depending to the connector type see sect. 15
Duty factor	Continuous rating (ED=100%)

13 DIAGRAMS (based on mineral oil ISO VG 46 at 50 °C)

13.1 Regulation diagrams
with flow rate Q = 10 l/min

1 = AGRCZO-A, AGRCZO-AE; AGRCZO-AES

Note:

The presence of counter pressure at port T can affect the effective pressure regulation.

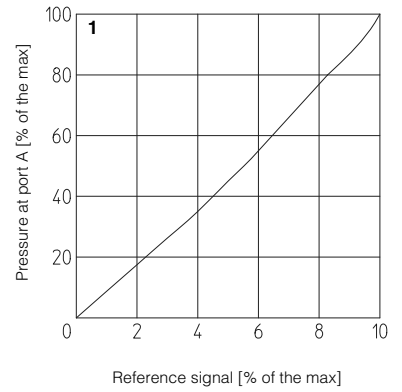

13.2 Pressure/flow diagrams

with reference pressure set with Q = 10 l/min

2 = AGRCZO-A, AGRCZO-AE, AGRCZO-AES

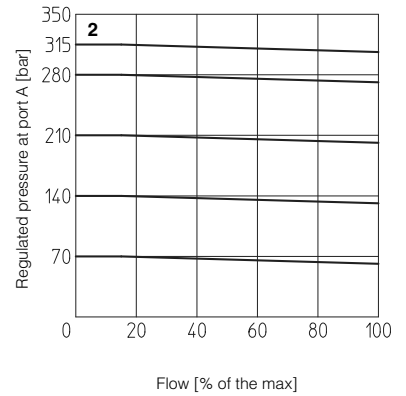

13.3 Pressure drop/flow diagrams

3 = AGRCZO-* -10

4 = AGRCZO-* -20

5 = AGRCZO-* -10*/R

6 = AGRCZO-* -20*/R

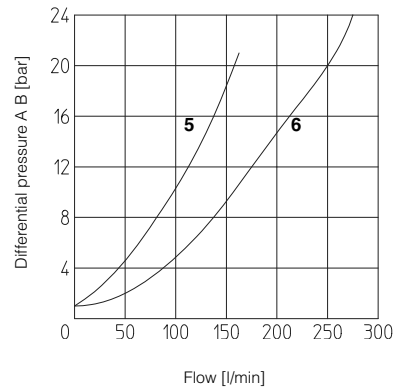
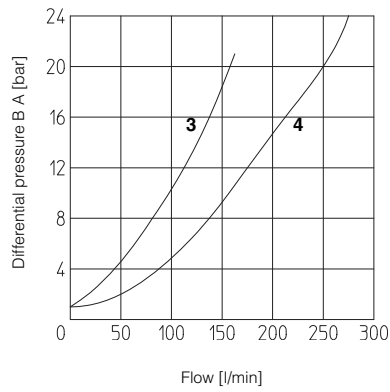

14 INSTALLATION DIMENSIONS of AGRCZO [mm]

AGRCZO-*-10

ISO 5781: 2000
 Mounting surface: 5781-06-07-0-00
 (see table P005)

Fastening bolts:
 4 socket head screws M10x45 class 12.9
 Tightening torque = 70 Nm
 Seals: 2 OR 109/70 ; 2 OR 3068
 Diameters of ports A, B: $\varnothing = 14$ mm
 Diameters of ports X, Y: $\varnothing = 5$ mm

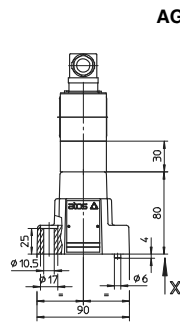

AGRCZO-A-10

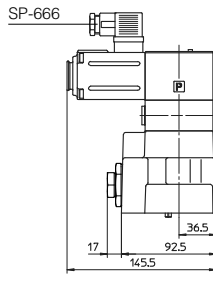

Mass: 5 Kg

AGRCZO-A/**/P

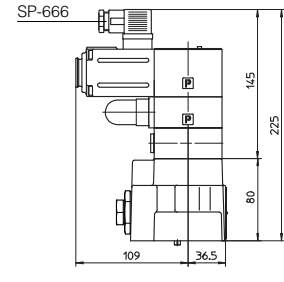

Mass: 5,5 Kg

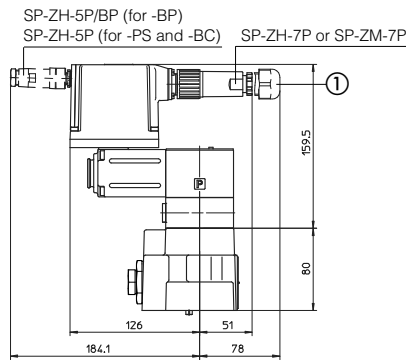

AGRCZO-AE-10
 (-AES-* dotted line)

Mass: 5,6 Kg

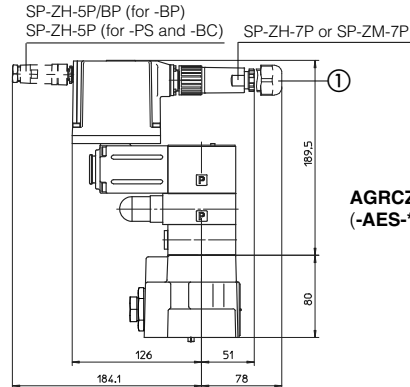

AGRCZO-AE-10/**/P
 (-AES-* dotted line)

Mass: 6,1 Kg

① = 12 pin connector SP-ZH-12P (option/Z)

AGRCZO-*-20

ISO 5781: 2000
 Mounting surface: 5781-08-10-0-00
 (see table P005)

Fastening bolts:
 4 socket head screws M10x45 class 12.9
 Tightening torque = 70 Nm
 Seals: 2 OR 109/70 ; 2 OR 4100
 Diameters of ports A, B: $\varnothing = 22$ mm
 Diameters of ports X, Y: $\varnothing = 5$ mm

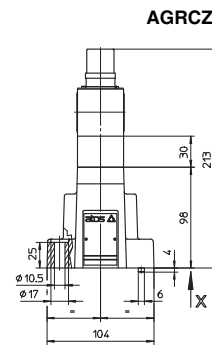

AGRCZO-A-20

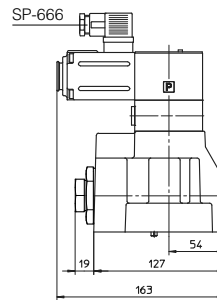

Mass: 7,5 Kg

AGRCZO-A/**/P

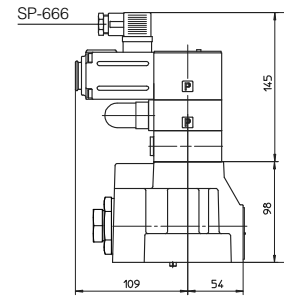

Mass: 8 Kg

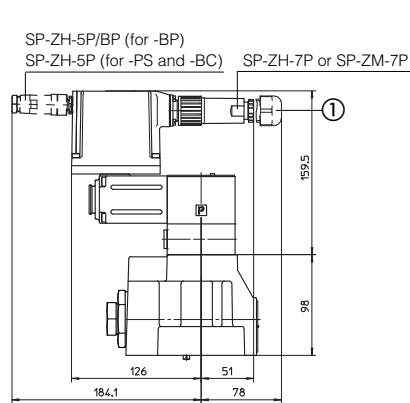

AGRCZO-AE-20
 (-AES-* dotted line)

Mass: 8,1 Kg

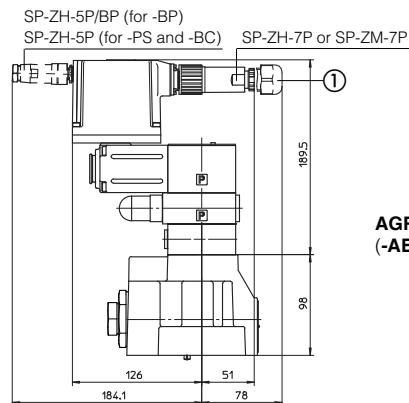

AGRCZO-AE-20/**/P
 (-AES-* dotted line)

Mass: 8,6 Kg

① = 12 pin connector SP-ZH-12P (option/Z)

15 MODEL CODES OF POWER SUPPLY AND COMMUNICATION CONNECTORS (to be ordered separately)

VALVE VERSION	-A	-AE, -AES		-AES/Z	-Serial (-PS) or CANopen (-BC)	PROFIBUS DP (-BP)
CONNECTOR CODE	SP-666	SP-ZH-7P	SP-ZM-7P	SP-ZH-12P	SP-ZH-5P	SP-ZH-5P/BP
PROTECTION DEGREE	IP65	IP67	IP67	IP65	IP67	IP67
DATA SHEET	K500	G110, G115, K500			G115, K500	

connectors supplied with the valve