

Proportional relief valves type **RZMO-TERS, AERS**

pilot operated, with integral or remote pressure transducer, ISO 4401 size 06

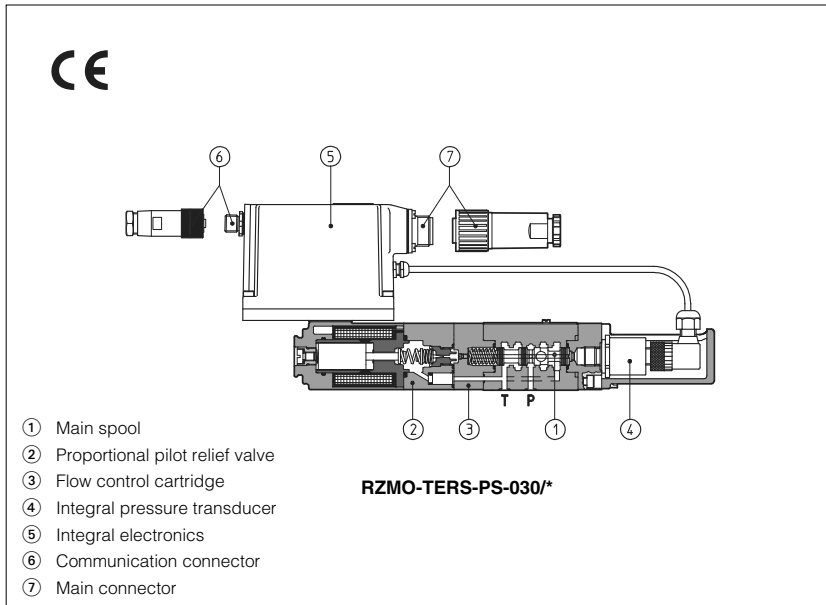

RZMO are spool type proportional pressure relief valves, pilot operated with integral or remote pressure transducer, which provide pressure regulation proportional to electronic reference signals.

They operate in association with electronic drivers, see section 2, which supply the proportional valve with proper current to align valve regulation to the reference signal supplied to the electronic driver.

They are available in different executions:

- -TERS with integral pressure transducer ④ plus digital electronics ⑤ preset in closed loop, featuring improved static and dynamic performances.
- -AERS as -TERS but without integral pressure transducer (predisposed for connection of remote pressure transducer).

The system pressure is controlled by the main spool ①, piloted by the proportional pilot relief valve ②.

The intermediate compensated flow control cartridge ③ assures constant pilot flow and therefore high pressure stability.

The integral electronics ensures factory presetting, fine functionality plus valve-to-valve interchangeability and simplified wiring and installation.

The electronic main connector ⑦ is fully interchangeable for -TERS and -AERS. Standard 7 pin connector is used for power supply, analog input reference and monitor signals.

12 pin connector is used for option /Z.

Following communication interfaces ⑥ are available:

- -PS, Serial communication interface. The valve reference signal is provided with analogue commands
- -BC, CANopen interface
- -BP, PROFIBUS DP interface

The valves with -BC and -BP interfaces can be integrated into a fieldbus communication network and thus digitally operated by the machine control unit.

The coils are fully plastic encapsulated (insulation class H), and the valves have antivibration, antishock and weather-proof features.

Mounting surface: ISO 4401, size 06

Max flow: 40 l/min

Max pressure: 315 bar.

1 MODEL CODE

| | | |
|---|------------------------------------|---|
| RZMO | - TERS - PS - 030 / 315 / * | ** / * |
| Proportional pressure relief valve size 06 | | Synthetic fluids WG = water-glycol PE = phosphate ester |
| TERS = with integral digital electronics and pressure transducer AERS = as TERS but predisposed for connection of remote pressure transducer (to be ordered separately, see tab. G465) | | Series number |
| Communication interfaces: PS = Serial BC = CANopen BP = PROFIBUS-DP | | Electronics options, see section 1: I = current reference input and monitor (4 ÷ 20 mA) signals Z = double power supply, enable fault and monitor signals (12 pin connector) C = remote pressure transducer with current feedback 4÷20 mA (only for AERS executions) |
| Configuration: 030 = regulation on port P, discharge in T | | |
| Pressure range: 100 = 100 bar 210 = 210 bar 315 = 315 bar | | |

2 ELECTRONIC DRIVERS FOR RZMO

| | | |
|---------------|--------------|--------------|
| Valve model | -TERS | -AERS |
| Drivers model | E-RI-TERS | E-RI-AERS |
| Data sheet | G205 | |

Note: for power supply and communication connector see section 11

3 HYDRAULIC CHARACTERISTICS (based on mineral oil ISO VG 46 at 50 °C)

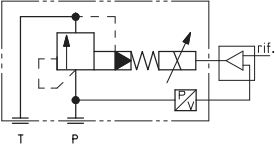
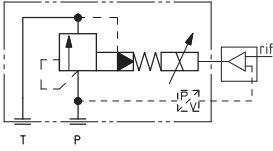
| Hydraulic symbols | |
|--|--|
|  RZMO-TERS-030 |  RZMO-AERS-030 |
| Valve model | RZMO-TERS, RZMO-AERS |
| Max. regulated pressure (Q = 10 l/min) | 100 210 315 |
| Min. regulated pressure (Q = 10 l/min) [bar] | 6 |
| Max. pressure at ports P, T [bar] | port P = 315 bar; port T 210 bar |
| Minimum flow [l/min] | 2,5 |
| Maximum flow [l/min] | 40 |
| Response time 0-100% step signal (depending on installation) - see section 9.4 [ms] | 45 |
| Hysteresis [% of the max regulated pressure] | ≤ 0,5 |
| Linearity [% of the max regulated pressure] | ≤ 1,0 |
| Repeatability [% of the max regulated pressure] | ≤ 0,2 |
| Thermal drift | zero point displacement < 1% at ΔT = 40°C |

4 MAIN CHARACTERISTICS OF PROPORTIONAL RELIEF VALVES

| | |
|----------------------------------|---|
| Assembly position | Any position |
| Subplate surface finishing | Roughness index, \sqrt{Ra} flatness ratio 0,01/100 (ISO 1101) |
| Ambient temperature | -20°C ÷ +50°C for -TERS and -AERS executions |
| Fluid | Hydraulic oil as per DIN 51524 ... 535 for other fluids see section 11 |
| Recommended viscosity | 15 ÷ 100 mm ² /s at 40°C (ISO VG 15÷100) |
| Fluid contamination class | ISO 18/15 achieved with in line filters of 10 μm and β ₁₀ ≥ 75 (recommended) |
| Fluid temperature | -20°C +60°C (standard and /WG seals) -20°C +80°C (/PE seals) |
| Coil resistance R at 20°C | 3 ÷ 3.3 Ω |
| Max solenoid current | 2,6 A |
| Max power | 40 Watt |
| Protection degree (CEI EN-60529) | IP65÷67, depending to the connector type see sect 11 |
| Duty factor | Continuous rating (ED=100%) |

5 GENERAL NOTES

RZMO proportional valve are CE marked according to the applicable Directives (e.g. Immunity/Emission EMC Directive).

Installation, wirings and start-up procedures must be performed according to the general prescriptions shown in table F003 and in the installation notes supplied with relevant components.

The electrical signals of the valve (e.g. monitor signals) must not be directly used to activate safety functions, like to switch-ON/OFF the machine's safety components, as prescribed by the European standards (Safety requirements of fluid technology systems and components-hydraulics, EN-982).

6 DIGITAL INTEGRAL DRIVERS -TERS and -AERS -OPTIONS

Standard driver execution provides on the 7 pin main connector:

Power supply - 24V_{dc} must be appropriately stabilized or rectified and filtered; a 2,5 A safety fuse is required in series to each driver power supply
Apply at least a 10000 μF/40 V capacitance to single phase rectifiers or a 4700 μF/40 V capacitance to three phase rectifiers

Reference input signal - analog differential input with 0÷+10 V_{dc} nominal range (pin D,E), proportional to desired valve pressure regulation

Monitor output signal - analog output signal proportional to the actual valve pressure regulation = 0÷+10 V_{dc} nominal range

Following options are available to adapt standard execution to special application requirements:

6.1 Option /I

It provides 4÷20 mA current reference and monitor signals instead of the standard 0÷+10 V_{dc}.

It is normally used in case of long distance between the machine control unit and the valve or where the reference signal can be affected by electrical noise; the valve functioning is disabled in case of reference signal cable breakage.

6.2 Option /Z

It provides on a 12 pin main connector the above standard features plus:

Logic power supply

Option /Z provides separate power supply for the solenoid (pin 1, 2) and for the digital electronic circuits (pin 9, 10).

Cutting solenoid power supply allows to interrupt the valve functioning but keeping energized the digital electronics thus avoiding fault conditions of the machine fieldbus controller. This condition allows to realize safety systems in compliance with European Norms EN13849-1 (ex EN954-1).

Enable Input Signal

To enable the driver, supply a 24V_{dc} on pin 3 referred to pin 2: when the Enable signal is set to zero the valve functioning is disabled (zero current to the solenoid) but the driver current output stage is still active. This condition does not comply with European Norms EN13849-1 (ex EN954-1).

Fault Output Signal

Fault output signal indicates fault conditions of the driver (solenoid short circuits/not connected, reference signal cable broken for 4÷20mA input, etc.). Fault presence corresponds to 0 V_{dc}, normal working corresponds to 24V_{dc} (pin 11 referred to pin 2): Fault status is not affected by the Enable input signal

6.3 Option /C (only for -AERS version)

The valve electronics is set to receive the 4÷20 mA feedback signal from the remote pressure transducer, instead of the standard 0÷10 V.

6.4 Possible combined options: /CI, /CIZ, /CZ (only for -AERS) and /IZ.

7 DIGITAL INTEGRAL DRIVERS -TERS and -AERS -main functions and electronic connectors

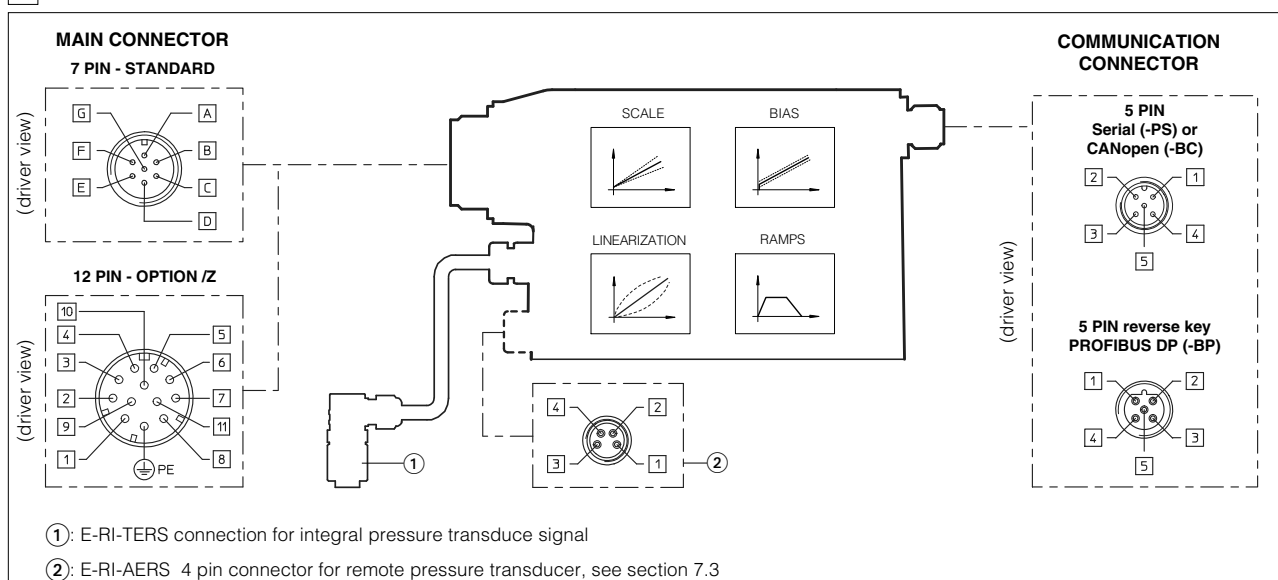

7.1 ELECTRONIC CONNECTIONS - 7 & 12 PIN MAIN CONNECTOR

| Standard 7pin | /Z option 12pin | SIGNAL | TECHNICAL SPECIFICATIONS | NOTES |
|---------------|-----------------|---------|---|------------------------|
| A | 1 | V+ | Power supply 24 V _{dc} for solenoid power stage (and for driver logic on 7 pin connection) | Input - power supply |
| B | 2 | V0 | Power supply 0 V _{dc} for solenoid power stage (and for driver logic on 7 pin connection) | Gnd - power supply |
| - | 3 | ENABLE | Enable (24 V _{dc}) or disable (0 V _{dc}) the driver | Input - on/off signal |
| D | 4 | INPUT+ | Reference analog input: ±10 V _{dc} maximum range (4 ÷ 20 mA for /I option) Normal working range 0 ÷ +10 V _{dc} (4 ÷ 20 mA for /I option) | Input - analog signal |
| E | - | INPUT - | differential INPUT+ and INPUT- (for 7 pin standard execution) common mode INPUT+ referred to AGND (only for /Z option) | |
| C | 5 | AGND | Ground : signal zero for MONITOR signal (pin F of 7 pin standard or pin 6 of /Z option) signal zero for INPUT+ signal (only for /Z option) | Gnd - analog signal |
| F | 6 | MONITOR | Monitor analog output: ±10 V _{dc} maximum range | Output - analog signal |
| - | 7 | NC | do not connect | |
| - | 8 | NC | do not connect | |
| - | 9 | VL+ | Power supply 24 V _{dc} for driver's logic | Input - power supply |
| - | 10 | VLO | Power supply 0 V _{dc} for driver's logic | Gnd - power supply |
| - | 11 | FAULT | Driver status : Fault (0V _{dc}) or normal working (24 V _{dc}) | Output - on/off signal |
| G | PE | EARTH | Internally connected to driver housing | |

Note: A minimum time of 270 to 590 ms have be considered between the driver energizing with the 24 V_{dc} power supply and when the valve is ready to operate. During this time the current to the valve coils is switched to zero

7.2 ELECTRONIC CONNECTIONS - 5 PIN COMMUNICATION CONNECTORS

| PIN | -PS Serial | | -BC CANopen | | -BP PROFIBUS DP | |
|-----|------------|-------------------------------|-------------|-------------------------|-----------------|---------------------------------------|
| | SIGNAL | TECHNICAL SPECIFICATION | SIGNAL | TECHNICAL SPECIFICATION | SIGNAL | TECHNICAL SPECIFICATION |
| 1 | NC | do not connect | CAN_SHLD | Shield | +5V | for termination |
| 2 | NC | do not connect | NC | do not connect | LINE-A | Bus line (high) |
| 3 | RS_GND | Signal zero data line | CAN_GND | Signal zero data line | DGND | data line and termination Signal zero |
| 4 | RS_RX | Valves receiving data line | CAN_H | Bus line (high) | LINE-B | Bus line (low) |
| 5 | RS_TX | Valves transmitting data line | CAN_L | Bus line (low) | SHIELD | |

7.3 ELECTRONIC CONNECTIONS - 4 PIN REMOTE PRESSURE TRANSDUCER M8 CONNECTOR (only for AERS)

| PIN | standard version | | /C option (Ri = 316 Ω) | |
|-----|------------------|---|------------------------|--|
| 1 | TR | remote trasducer pressure signal (0 ÷ +10 V _{dc}) | TR | remote trasducer pressure signal (4 ÷ 20 mA) |
| 2 | NC | reserved (do not connect) | NC | reserved (do not connect) |
| 3 | VT | remote transducer power supply +24 V _{dc} | VT | remote transducer power supply +24 V _{dc} |
| 4 | AGND | signal zero for power supply and signal | NC | reserved (do not connect) |

See tab. G465 for the pressure transducer characteristics and connections.

8 SOFTWARE TOOLS

The functional parameters of digital valves, as the bias, scale ramp and linearization of the regulation characteristic, can be easily set and optimized with the Atos E-SW programming software, available in three different versions according to the driver's communication interfacing: E-SW-PS (Serial), E-SW-BC (CANopen) and E-SW-BP (PROFIBUS DP).

A proper connection is required between the PC and the electronic driver communication port: for a more detailed description of software interface, PC requirements, adapters, cables and terminators, please **see table G500**.

Proportional valves with fieldbus communication interface (-BC and -BP) can be directly managed by the machine control unit; it is required to implement in the machine control the standard communication as described in the user manuals supplied with the relevant programming software. For detailed description of available fieldbus feature, **see table G510**.

On first supply of the E-SW software, it is required to apply for the registration in the Atos download area: www.download.atos.com

Once the registration is completed, the password will be sent by email.

The software remains active for 10 days from the installation date and then it stops until the user inputs his password.

With the password you can also download, in your personal area, the latest releases of the Atos software, manuals, drivers and configuration files.

9 DIAGRAMS (based on mineral oil ISO VG 46 at 50 °C)

9.1 Regulation diagrams
with flow rate Q = 10 l/min

1 = RZMO-TERS, RZMO-AERS

Note:

The presence of counter pressure at port T can affect the effective pressure regulation.

9.2 Pressure/flow diagrams
with reference signal set at Q = 10 l/min

2 = RZMO-TERS, RZMO-AERS

9.3 Minimum pressure/flow diagrams
with zero reference signal

3 = RZMO-TERS, RZMO-AERS

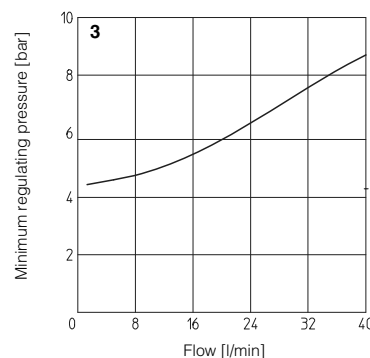
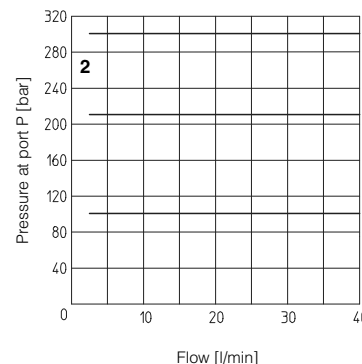
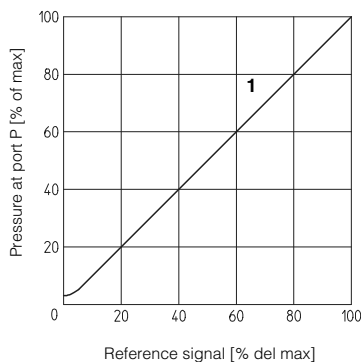

9.4 Dynamic response

The response times in section 8 have to be considered as average values.

The pressure variation in consequence of a modification of the reference input signal to the valve is affected by the stiffness of the hydraulic circuit: greater is the stiffness of the circuit, faster is the dynamic response. The valves dynamic performances can be optimized depending on the stiffness characteristics of the hydraulic circuit, by setting the internal software parameters. This regulation is particularly helpful in case of circuits with accumulators and/or with great fluid volumes and/or with long hoses.

10 INSTALLATION DIMENSIONS [mm]

ISO 4401: 2000

Mounting surface: 4401-03-02-0-05
(see table P005)

Fastening bolts:
4 socket head screws M5X50 bolts class 12.9
Tightening torque = 8 Nm
Seals: 4 OR 108
Ports A, B not used

RZMO-TERS-*
Mass: 3,3 Kg

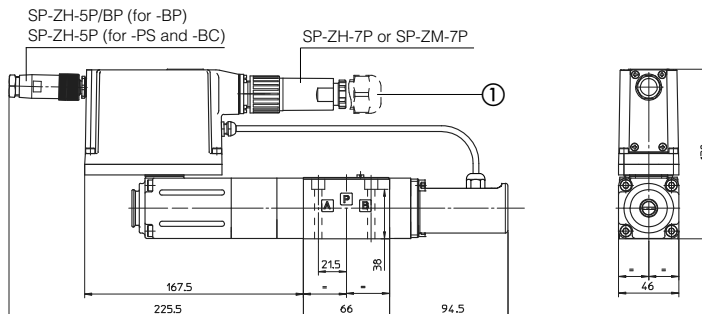

RZMO-AERS-*
Mass: 3,9 Kg

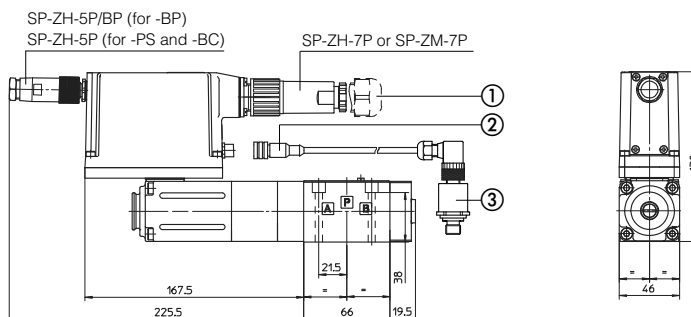

- ① = 12 pin connector SP-ZH-12P (option/Z)
- ② = 4 pin connector SP-ZH-4P-M8/5 (see tab. G205)
- ③ = remote pressure transducer, to be ordered separately (see tab. G465)

11 MODEL CODES OF POWER SUPPLY AND COMMUNICATION CONNECTORS (to be ordered separately)

| VALVE VERSION | -AERS, -TERS | | -AERS/Z -TERS/Z | -Serial (-PS) or CANopen (-BC) | PROFIBUS DP (-BP) | Pressure transducer only for -AERS |
|-------------------|--------------|----------|--------------------|-----------------------------------|-------------------|---------------------------------------|
| CONNECTOR CODE | SP-ZH-7P | SP-ZM-7P | SP-ZH-12P | SP-ZH-5P | SP-ZH-5P/BP | SP-ZH-4P-M8/5 (1) |
| PROTECTION DEGREE | IP67 | IP67 | IP65 | IP67 | IP67 | IP67 |
| DATA SHEET | G205, K500 | | | | | |

(1) M8 connector SP-ZH-4P-M8/5 moulded on cable 5 mt length for pressure transducer