

# Servoproportional valves type DLHZO and DLKZOR

sleeve execution, direct operated, with position transducer, ISO 4401 size 06 and 10

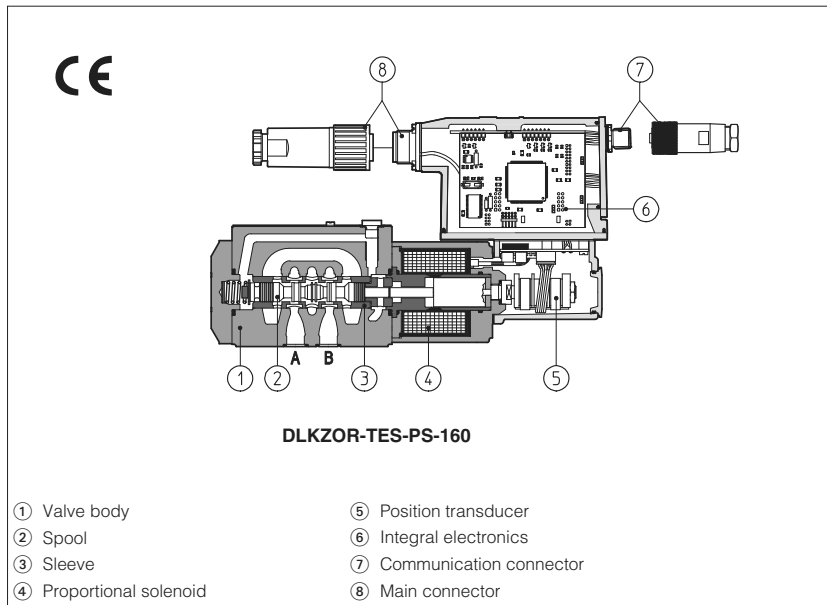

## 1 MODEL CODE

**DLHZO - TES - PS - 0 4 0 - L 7 3 / \* / \*\* / \***

**DLHZO** = size 06  
**DLKZOR** = size 10

**T** = with position transducer  
**TE** = as T plus integral electronics  
**TES** = as T plus integral digital electronics

Communication interfaces (only for TES)  
**PS** = Serial  
**BC** = CANopen  
**BP** = PROFIBUS DP

Valve size, see section 2  
**0** = ISO 4401 size 06 **1** = ISO 4401 size 10

Valve configuration, see section 2  
**4** = 2 external position, spring offset, fail safe  
**6** = 2 external position, spring offset

**0** = zero overlapping

Spool type (regulating characteristics)  
**L** = linear;  
**D** = differential-linear (as L, but with P-A = Q, P-B = Q/2) (1)  
**DT** = as D, but with non linear regulation (1)  
**T** = not linear regulation (1)  
**V** = progressive

**0, 1, 3, 5, 7** = spool size, see section 3

Fail safe configuration (de-energized solenoid):  
**1** = A, B, P, T with positive overlapping (20% of spool stroke)  
**3** = P positive overlapping (20% of spool stroke); A, B, T negative

### Note:

(1) Spool type **D**, **DT** and **T** are available only for valve configuration with fail safe position DLHZO\*-040 and DLKZOR\*-140

Synthetic fluids  
**WG** = water-glycol  
**PE** = phosphate ester

Series number

### Hydraulic options, see section 4:

**B** = solenoid, integral electronics and position transducer at side of port A  
**Y** = external drain

### Electronics options, for -TE execution see section 7:

**F** = fault signal  
**I** = current reference input and monitor (4÷20 mA)  
**Q** = enable signal  
**Z** = enable, fault and monitor signals (12 pin connector)

### Electronics options, for -TES execution see section 9:

**I** = current reference input and monitor (4÷20mA)  
**Z** = double power supply, enable fault and monitor signals (12 pin connector)

### Special options for -TES execution see section 9:

**SF** = additional closed loop force control, with two remote pressure transducers  
**SL** = additional closed loop force control with one remote load cell  
**SP** = additional closed loop pressure control with one remote pressure transducer  
**C** = current feedback interface for transducer(s) **only for options /SF, /SL, /SP**

DLHZO and DLKZOR are high performance servoproportional valves, direct operated, with sleeve execution and LVDT position transducer, which provide both directional and non compensated flow control according to the electronic reference signal.

They operate in association with electronic drivers, see section 2, which supply the proportional valves with proper current to align valve regulation to the reference signal supplied to the electronic driver.

They are available in different executions:

- -T, with integral position transducer ⑤;
- -TE, -TES as -T plus analog (TE) or digital (TES) integral electronics ⑥.

The 4-way spool ② is sliding into a precision - machined and hardened sleeve ③ for maximum overlapping accuracy. The sleeve ③ is mechanically forced into a 5-chambers body ①. The spool is directly operated by a proportional solenoids ④ and it is controlled in closed loop position by means of the LVDT position transducer ⑤.

The integral electronics ⑥ ensures factory presetting, fine functionality plus valve-to-valve interchangeability and simplified wiring and installation.

The electronic main connector ⑧ is fully interchangeable for -TE and -TES executions.

Standard 7 pin main connector is used for power supply, analog input reference and monitor signals.

12 pin connector is used for options /Z and /S\*.

The special /S\* options add a closed loop control of pressure (/SP) or force (/SF and /SL) to the basic closed loop spool position one.

Following communication interfaces ⑦ are available for the digital -TES execution:

- -PS, Serial communication interface. The valve reference signal is provided with analogue commands

- -BC, CANopen interface
- -BP, PROFIBUS DP interface

The valves with -BC and -BP interfaces can be integrated into a fieldbus communication network and thus digitally operated by the machine control unit.

The coils are fully plastic encapsulated (insulation class H) and the valves have antivibration, antishock and weather-proof features.

Mounting Surface: ISO 4401 sizes 06 and 10.

Max flow respectively up to 40 l/min and 100 l/min with valve differential pressure  $\Delta p = 70$  bar, see table 3.

Max pressure = 350 bar

## 2 ELECTRONIC DRIVERS

Valve model	-T	-TE	-TES	-TES / SF, SL, SP
Drivers model	E-ME-T	E-RI-TE	E-RI-TES	E-RI-TES / SF, SL, SP
Data sheet	G140	G200	G210	G212

Note: For power supply and communication connector see section 15 and 17

### 3 HYDRAULIC CHARACTERISTICS (based on mineral oil ISO VG 46 at 50 °C)

Hydraulic symbols		*40-L*3 *40-D*3 *40-DT*3 *40-T*3 *40-V*3		*40-L*1 *40-D*1 *40-DT*1 *40-T*1 *40-V*1		*60-L*1 *60-V*1												
		*40-L*3/B *40-D*3/B *40-DT*3/B *40-T*3/B *40-V*3/B		*40-L*1/B *40-D*1/B *40-DT*1/B *40-T*1/B *40-V*1/B		*60-L*1/B *60-V*1/B												
Valve model	<b>DLHZO-T*</b>				<b>DLKZOR-T*</b>													
Pressure limits [bar]	ports P, A, B = 350; T = 210 (250 with external drain /Y)				ports P, A, B = 315; T = 210 (250 with external drain /Y)													
Spool	<b>L0</b>	<b>L1</b>	<b>V1</b>	<b>L3</b>	<b>V3</b>	<b>L5</b>	<b>T5</b>	<b>L7</b>	<b>T7</b>	<b>V7</b>	<b>D7</b>	<b>DT7</b>	<b>L3</b>	<b>L7</b>	<b>T7</b>	<b>V7</b>	<b>D7</b>	<b>DT7</b>
Max flow (1) [l/min]	2,5	4,5	5	9	13	18		26		26÷13			40		60		60÷33	
at Δp = 30 bar	4	7	8	14	20	28		40		40÷20			60		100		100÷50	
at Δp = 70 bar	10	18	18	32	40	50		70		70÷40			90		160		160÷80	
max permissible flow																		
Leakage [cm <sup>3</sup> /min] at P = 100 bar (2)	<100	<200	<100	<300	<150	<500	<200	<900	<200	<200	<700	<200	<1000	<1500	<400	<400	<1200	<400
Response time [ms]	≤ 10																	
Hysteresis [%]	≤ 0,1%																	
Thermal drift	zero point displacement < 1% at ΔT = 40°C																	

#### Notes:

- Above performance data refer to valves coupled with Atos electronic drivers, see sections [2].
- The flow regulated by the directional proportional valves is not pressure compensated, thus it is affected by the load variations. To keep constant the regulated flow under different load conditions, modular pressure compensators are available (see tab. D150).

(1) For different Δp, the max flow is in accordance to the diagrams in section 13.2

(2) Referred to spool in neutral position and 50°C oil temperature.

### 4 HYDRAULIC OPTIONS

**4.1 Option /B** Solenoid, integral electronics and position transducer at side of port A.

**4.2 Option /Y** External drain is mandatory if the pressure in port T exceeds 160 bar.

### 5 GENERAL NOTES

DLHZO and DLKZOR servoproportional valves are CE marked according to the applicable Directives (e.g. Immunity/Emission EMC Directive).

Installation, wirings and start-up procedures must be performed according to the general prescriptions shown in table F003 and in the installation notes supplied with relevant components.

The electrical signals of the valve (e.g. monitor signals) must not be directly used to activate safety functions, like to switch-ON/OFF the machine's safety components, as prescribed by the European standards (Safety requirements of fluid technology systems and components-hydraulics, EN-982).

### 6 CONNECTIONS FOR -T EXECUTION

SOLENOID POWER SUPPLY CONNECTOR	
PIN	Signal description
<b>1</b>	SUPPLY
<b>2</b>	SUPPLY
<b>3</b>	GND

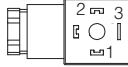

POSITION TRANSDUCER CONNECTOR	
PIN	Signal description
<b>1</b>	OUTPUT SIGNAL
<b>2</b>	SUPPLY -15 V <sub>DC</sub>
<b>3</b>	SUPPLY +15 V <sub>DC</sub>
<b>4</b>	GND

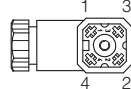

### 7 ANALOG INTEGRAL DRIVERS -TE - OPTIONS

Standard driver execution provides on the 7 pin main connector:

- Power supply** - 24V<sub>DC</sub> must be appropriately stabilized or rectified and filtered; a 2,5 A safety fuse is required in series to the driver power supply. Apply at least a 10000 μF/40 V capacitance to single phase rectifiers or a 4700 μF/40 V capacitance to three phase rectifiers
- Reference input signal** - analog differential input with ±10 V<sub>DC</sub> nominal range (pin D,E), proportional to desired valve spool position
- Monitor output signal** - analog output signal proportional to the actual valve's spool position with ±10 V<sub>DC</sub> nominal range

Following options are available to adapt standard execution to special application requirements:

#### 7.1 Option /F

It provides a Fault output signal in place of the Monitor output signal, to indicate fault conditions of the driver (cable interruption of spool transducers or reference signal - for /I option): Fault presence corresponds to 0 V<sub>DC</sub>, normal working corresponds to 24 V<sub>DC</sub>.

#### 7.2 Option /I

It provides the 4÷20 mA current reference and monitor signals instead of the standard ±10 V<sub>DC</sub>. It is normally used in case of long distance between the machine control unit and the valve or where the reference signal can be affected by electrical noise; the valve functioning is disabled in case of reference signal cable breakage.

#### 7.3 Option /Q

It provides the possibility to enable or disable the valve functioning without cutting the power supply (the valve functioning is disabled but the driver current output stage is still active). To enable the driver supply a 24V<sub>DC</sub> on the enable input signal.

#### 7.4 Option /Z

This option includes /F and /Q features, plus the Monitor output signal. When the driver is disabled (0 V<sub>DC</sub> on Enable signal) Fault output is forced to 0 V<sub>DC</sub>.

#### 7.5 Possible combined options: /FI and /IZ

## 8 ANALOG INTEGRAL DRIVERS -TE - MAIN FUNCTIONS AND ELECTRONIC CONNECTIONS

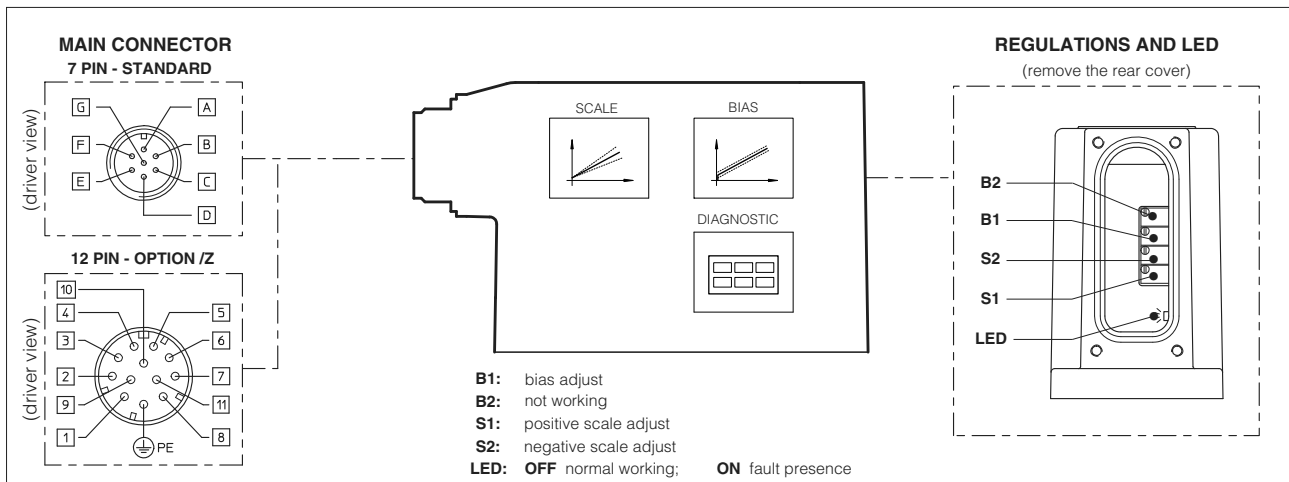

### 8.1 ELECTRONIC CONNECTIONS - 7 & 12 PIN MAIN CONNECTORS

Standard 7pin	/Z option 12pin	SIGNAL	TECHNICAL SPECIFICATIONS	NOTES
A	1	V+	Power supply 24 Vdc for solenoid power stage and driver logic	Input - power supply
B	2	V0	Power supply 0 Vdc for solenoid power stage and driver logic	Gnd - power supply
C <sup>(1)</sup>	7	AGND	Ground - signal zero for MONITOR signal (for standard and /Z options)	Gnd - analog signal
	3	ENABLE	Enable (24 Vdc) or disable (0 Vdc) the driver (for /Q and /Z options)	Input - on/off signal
D	4	INPUT+	Reference analog differential input: $\pm 10$ Vdc maximum range (4 $\div$ 20 mA for /I option)	Input - analog signal
E	5	INPUT -		
F <sup>(2)</sup>	6	MONITOR	Monitor analog output: $\pm 10$ Vdc maximum range (4 $\div$ 20 mA for /I option)	Output - analog signal
	11	FAULT	Fault (0V) or normal working (24V) (for F and /Z options)	Output - on/off signal
-	8	R_ENABLE	Repeat Enable - output repetition of Enable input	Output - on/off signal
-	9	NC	do not connect	Output - on/off signal
-	10	NC	do not connect	Output - on/off signal
G	PE	EARTH	Internally connected to the driver housing	

**Notes** (1) with /Q option ENABLE signal replaces AGND on pin C; MONITOR signal is referred to pin B

(2) with /F option FAULT signal replaces MONITOR on pin F.

A minimum time of 50ms to 100ms have to be considered between the driver energizing with the 24 Vdc power supply and when the valve is ready to operate. During this time the current to the valve coils is switched to zero.

## 9 DIGITAL INTEGRAL DRIVERS -TES - OPTIONS

Standard driver execution provides on the 7 pin main connector:

**Power supply** - 24Vdc must be appropriately stabilized or rectified and filtered; a 2,5 A safety fuse is required in series to each driver power supply. Apply at least a 10000  $\mu$ F/40 V capacitance to single phase rectifiers or a 4700  $\mu$ F/40 V capacitance to three phase rectifiers

**Reference input signal** - analog differential input with  $\pm 10$ Vdc nominal range (pin D,E), proportional to desired valve spool position

**Monitor output signal** - analog output signal proportional to the actual valve's spool position with  $\pm 10$ Vdc nominal range

Following options are available to adapt standard execution to special application requirements:

### 9.1 Option /I

It provides 4 $\div$ 20 mA current reference and monitor signals instead of the standard  $\pm 10$  V.

It is normally used in case of long distance between the machine control unit and the valve or where the reference signal can be affected by electrical noise; the valve functioning is disabled in case of reference signal cable breakage.

### 9.2 Option /Z

It provides on a 12 pin main connector the above standard features plus:

#### Logic power supply

Option /Z provides separate power supply for the solenoid (pin 1, 2) and for the digital electronic circuits (pin 9, 10).

Cutting solenoid power supply allows to interrupt the valve functioning but keeping energized the digital electronics thus avoiding fault conditions of the machine fieldbus controller. This condition allows to realize safety systems in compliance with European Norms EN13849-1 (ex EN954-1).

#### Enable Input Signal

To enable the driver, supply a 24Vdc on pin 3 referred to pin 2: when the Enable signal is set to zero the valve functioning is disabled (zero current to the solenoid) but the driver current output stage is still active. This condition does not comply with European Norms EN13849-1 (ex EN954-1).

#### Fault Output Signal

Fault output signal indicates fault conditions of the driver (solenoid short circuits/not connected, reference signal cable broken for 4 $\div$ 20mA input, etc.). Fault presence corresponds to 0 Vdc, normal working corresponds to 24Vdc (pin 11 referred to pin 2): Fault status is not affected by the Enable input signal

### 9.3 Options /SP, /SF and /SL

These options add the closed loop control of pressure (/SP) or force (/SF and /SL) to the basic functions of proportional directional valves: a dedicated software alternates pressure (force) and valve's spool position controls depending on the actual hydraulic system conditions.

A dedicated connector is available for the additional transducers that are required to be interfaced to the valve's driver (1 pressure transducer for /SP, 2 pressure transducers for /SF or 1 load cell for /SL).

Main 12 pin connector is the same as /Z option plus two analog signals specific for the pressure (force) control: one for reference (pin 7) and one for monitor (pin 8).

For further details please refer to the driver technical table **G212**.

### 9.4 Options /C

Options /CSP, /CSF and /CSL are available to connect pressure (force) transducers with 4  $\div$  20mA current output signal.

### 9.5 Possible combined options: /ISP, /ISF, /ISL, /CSP, /CSF, /CSL, /CISP, /CISF, /CISL and /IZ

## 10 DIGITAL INTEGRAL DRIVERS -TES - MAIN FUNCTIONS AND ELECTRONIC CONNECTIONS

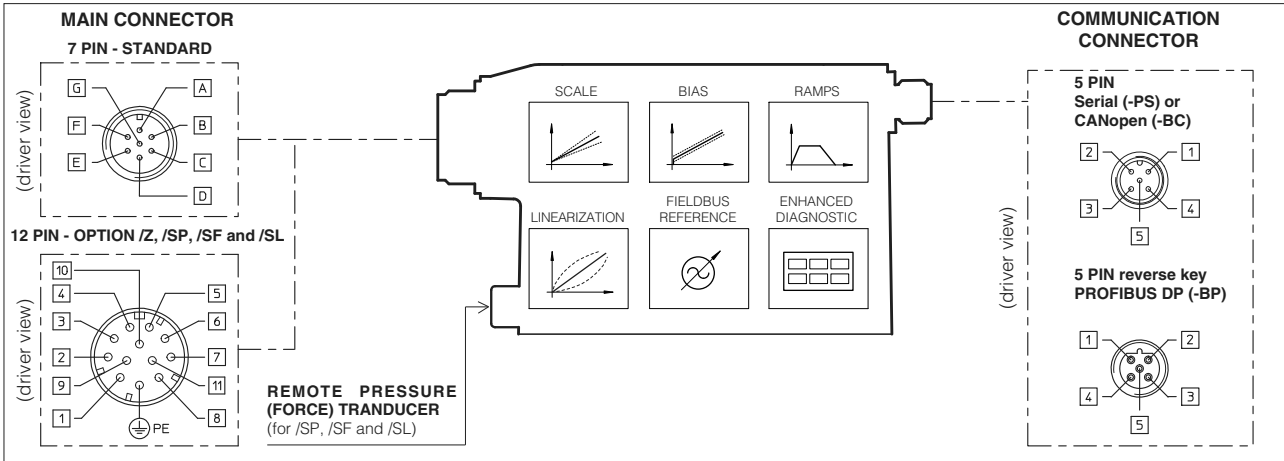

### 10.1 ELECTRONIC CONNECTIONS - 7 & 12 PIN MAIN CONNECTORS

Standard 7pin	/Z option 12pin	SIGNAL	TECHNICAL SPECIFICATIONS	NOTES
A	1	V+	Power supply 24 V <sub>DC</sub> for solenoid power stage (and for driver logic on 7 pin connection)	Input - power supply
B	2	V0	Power supply 0 V <sub>DC</sub> for solenoid power stage (and for driver logic on 7 pin connection)	Gnd - power supply
-	3	ENABLE	Enable (24 V <sub>DC</sub> ) or disable (0 V <sub>DC</sub> ) the driver	Input - on/off signal
D	4	INPUT+	Reference analog input: ±10 V <sub>DC</sub> maximum range (4 ÷ 20 mA for /I option) standard: differential input; /Z option: common mode INPUT+ referred to AGND	Input - analog signal
E	-	INPUT -		
C	5	AGND	Ground - signal zero for MONITOR signal signal zero for INPUT+ signal ( only for /Z option)	Gnd - analog signal
F	6	MONITOR	Monitor analog output: ±10 V <sub>DC</sub> maximum range (4 ÷ 20 mA for /I option)	Output - analog signal
-	7	NC	do not connect ( pressure/force input for /SP, /SF and /SL options, see 9.3 )	
-	8	NC	do not connect ( pressure/force monitor for /SP, /SF and /SL options, see 9.3 )	
-	9	VL+	Power supply 24 V <sub>DC</sub> for driver logic	Input - power supply
-	10	VL0	Power supply 0 V <sub>DC</sub> for driver logic	Gnd - power supply
-	11	FAULT	Fault (0V) or normal working (24V)	Output - on/off signal
G	PE	EARTH	Internally connected to the driver housing	

**Note:** A minimum time of 300 to 500 ms have be considered between the driver energizing with the 24 VDC power supply and when the valve is ready to operate. During this time the current to the valve coils is switched to zero.

### 10.2 ELECTRONIC CONNECTIONS - 5 PIN COMMUNICATION CONNECTORS

PIN	-PS Serial		-BC CANopen		-BP PROFIBUS DP	
	SIGNAL	TECHNICAL SPECIFICATION	SIGNAL	TECHNICAL SPECIFICATION	SIGNAL	TECHNICAL SPECIFICATION
1	NC	do not connect	CAN_SHLD	Shield	+5V	for termination
2	NC	do not connect	NC	do not connect	LINE-A	Bus line (high)
3	RS_GND	Signal zero data line	CAN_GND	Signal zero data line	DGND	data line and termination Signal zero
4	RS_RX	Valves receiving data line	CAN_H	Bus line (high)	LINE-B	Bus line (low)
5	RS_TX	Valves transmitting data line	CAN_L	Bus line (low)	SHIELD	

## 11 SOFTWARE TOOLS

The functional parameters of digital valves, as the bias, scale ramp and linearization of the regulation characteristic, can be easily set and optimized with the Atos E-SW programming software, available in three different versions according to the driver's communication interfacing: E-SW-PS (Serial), E-SW-BC (CANopen) and E-SW-BP (PROFIBUS DP).

A proper connection is required between the PC and the electronic driver communication port: for a more detailed description of software interface, PC requirements, adapters, cables and terminators, please **see table G500**.

Proportional valves with fieldbus communication interface (-BC and -BP) can be directly managed by the machine control unit; it is required to implement in the machine control the standard communication as described in the user manuals supplied with the relevant programming software. For detailed description of available fieldbus feature, **see table G510**.

On first supply of the E-SW software, it is required to apply for the registration in the Atos download area: [www.download.atos.com](http://www.download.atos.com)

Once the registration is completed, the password will be sent by email.

The software remains active for 10 days from the installation date and then it stops until the user inputs his password.

With the password you can also download, in your personal area, the latest releases of the Atos software, manuals, drivers and configuration files.

## 12 MAIN CHARACTERISTICS OF PROPORTIONAL DIRECTIONAL VALVES

Assembly position	Any position	
Subplate surface finishing	Roughness index, $\sqrt{Ra}$ flatness ratio 0,01/100 (ISO 1101)	
Ambient temperature	-20°C ÷ +70°C for -T execution; -20°C ÷ +60°C for -TE and TES executions	
Fluid	Hydraulic oil as per DIN 51524 ... 535 for other fluids see section [1]	
Recommended viscosity	15 ÷ 100 mm <sup>2</sup> /s at 40°C (ISO VG 15÷100)	
Fluid contamination class	ISO 18/15 achieved with in line filters of 10 µm and $\beta_{10} \geq 75$ (recommended)	
Fluid temperature	-20°C +60°C (standard and /WG seals) -20°C +80°C (/PE seals)	
Valve model	<b>DLHZO-T*</b>	<b>DLKZOR-T*</b>
Coil resistance R at 20°C	3 ÷ 3,3 Ω	3,8 ÷ 4,1 Ω
Max. solenoid current	2,6 A	3 A
Max. power	35 Watt	40 Watt
Insulation class	H (180°) Due to the occurring surface temperatures of the solenoid coils, the European standards ISO 13732-1 and EN982 must be taken into account	
Protection degree (CEI EN-60529)	IP65 for -T execution; IP65÷67 for -TE and -TES executions, depending to the connector type (see sect. [15] [17])	
Duty factor	Continuous rating (ED=100%)	

**13 DIAGRAMS** (based on mineral oil ISO VG 46 at 50 °C)

**13.1 Regulation diagrams**

- 1 = Linear spools L
- 2 = Differential - linear spool D7

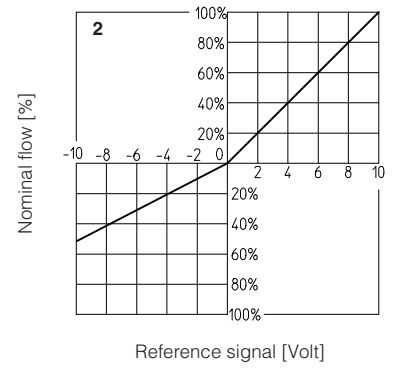
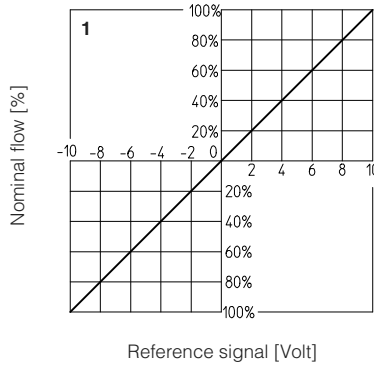

- 3 = Differential non linear spool DT7
- 4 = Non linear spool T5 (only for DLHZO)

T5 and T7 spool types are specific for fine low flow control in the range from 0 to 40% (T5) and 0 to 60% (T7) of max spool stroke. The non linear characteristics of the spool is compensated by the electronic driver, so the final valve regulation is resulting linear respect the reference signal (dotted line).

DT7 has the same characteristic of T7 but it is specific for applications with cylinders with area ratio 1:2

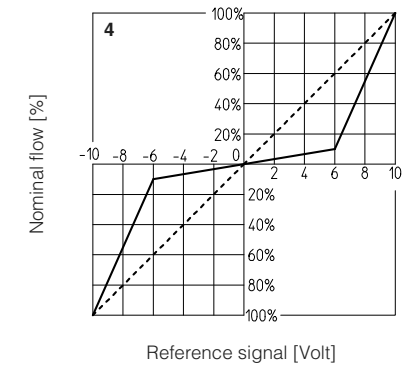
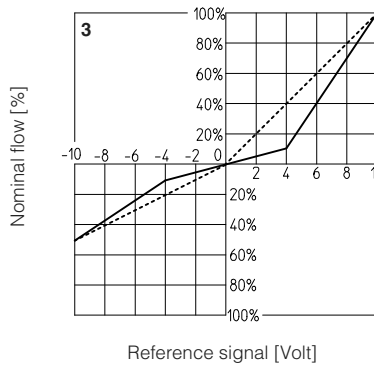

- 5 = Non linear spool T7
- 6 = Progressive spool V

**Note:**  
Hydraulic configuration vs. reference signal:  
Reference signal 0 ÷ +10 V P → A / B → T  
12 ÷ 20 mA

Reference signal 0 ÷ -10 V P → B / A → T  
4 ÷ 12 mA

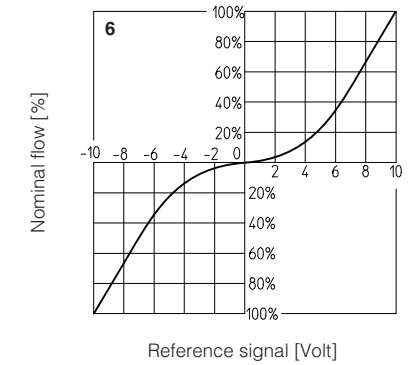
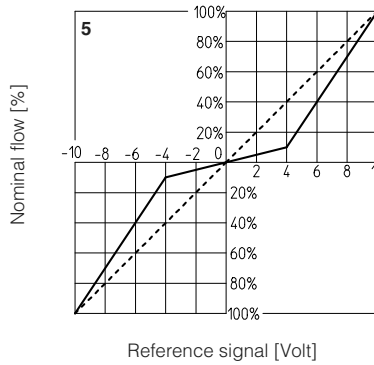

- 7 = Pressure gain

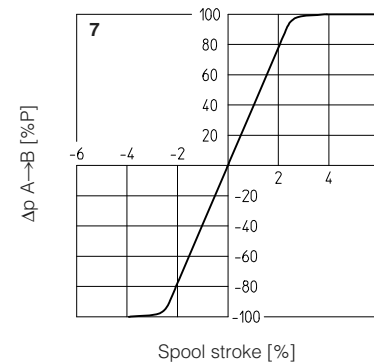

### 13.2 Flow / $\Delta p$ diagrams

Stated at 100% of spool stroke

DLHZO:

1 = spool L7, T7, V7, D7, DT7

2 = spool L5, T5

3 = spool V3

4 = spool L3

5 = spool L1, V1

6 = spool L0

DLKZOR:

7 = spool L7, T7, V7, D7, DT7

8 = spool L3

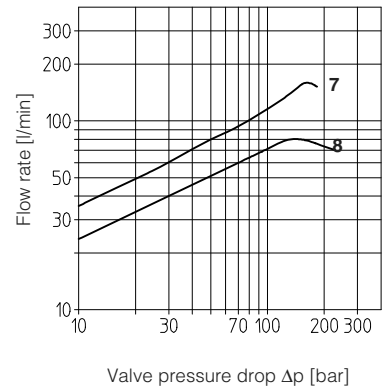
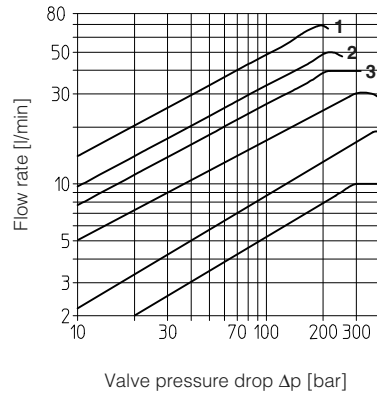

### 13.3 Bode diagrams

Stated at nominal hydraulic conditions

DLHZO:

1 =  $\pm$  100% nominal stroke

2 =  $\pm$  5% nominal stroke

DLKZOR:

3 =  $\pm$  100% nominal stroke

4 =  $\pm$  5% nominal stroke

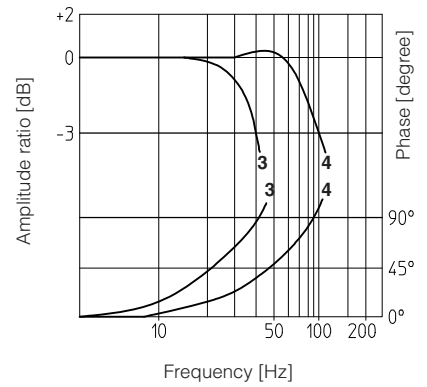
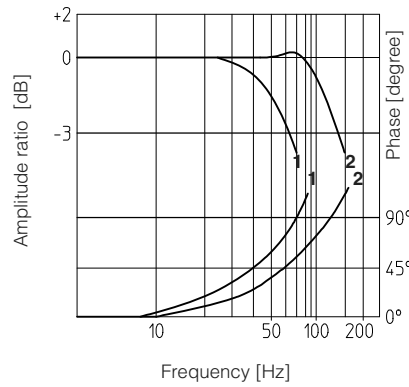

### 13.4 Dynamic response

The response times in section 13.1 have to be considered as average values.

For the valves with digital electronics the dynamics performances can be optimized by setting the internal software parameters.

**14** INSTALLATION DIMENSIONS [mm]

**ISO 4401: 2005**

**Mounting surface: 4401-03-02-0-05** (see table P005)  
**(for /Y version, surface: 4401-03-03-0-05 without X port)**

Fastening bolts:  
 4 socket head screws M5x50 class 12.9  
 Tightening torque = 8 Nm  
 Seals: 4 OR 108; 1 OR 2025/70  
 Diameter of ports A, B, P, T: Ø 7,5 mm (max)  
 Diameter of port Y: Ø 3,2 mm (only for /Y option)

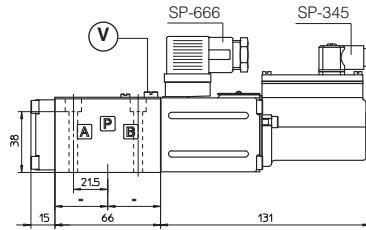

**DLHZO-T**

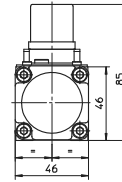

Mass: 2,3 kg

Note: for option /B the solenoid and the position transducer are at side of port A

Ⓟ = Air bleed off

**-TE EXECUTION**

① Dotted line = 12 poles connector SP-ZH-12P for option /Z

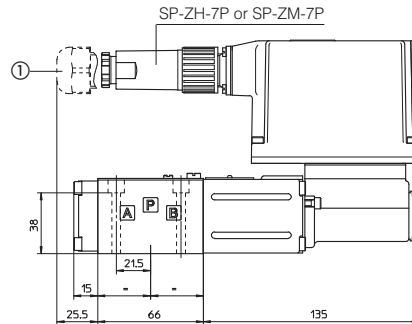

**DLHZO-TE**

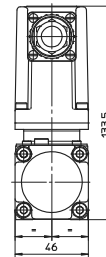

Mass: 2,8 kg

**-TES EXECUTION**

① Dotted line = 12 pin connector SP-ZH-12P for options /SF, /SL, /SP, /Z  
 ② Dotted line = M8 connector SP-ZH-4P-M8/5 moulded on cable 5 mt lenght for pressure or force transducer (options /SL, /SP)  
 M8 connector SP-ZH-4P-M8/2-2 moulded with 2 cables, 2 mt lenght for 2 pressure transducers (options /SF)

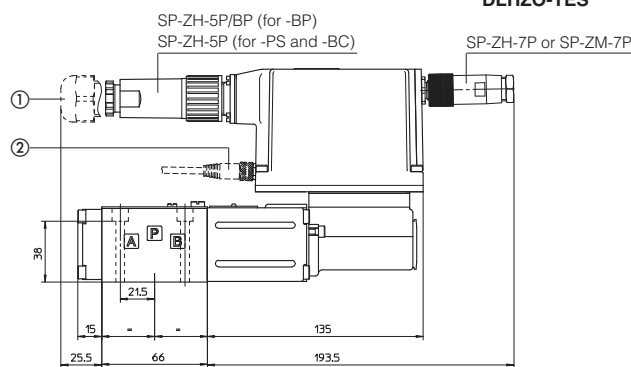

**DLHZO-TES**

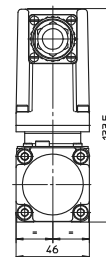

Mass: 2,8 kg

Note: for option /B the solenoid, the position transducer and the integral electronics are at side of port A

**15** MODEL CODES OF POWER SUPPLY AND COMMUNICATION CONNECTORS (to be ordered separately)

VALVE VERSION	-T Power supply   Transducer		-TE, -TES		-TE/Z -TES /Z, /SF, /SL, /SP	TES -PS, -BC	TES -BP	TES /SF, /SL, /SP
CONNECTOR CODE	SP-666	SP-345	SP-ZH-7P	SP-ZM-7P	SP-ZH-12P	SP-ZH-5P	SP-ZH-5P/BP	SP-ZH-4P-M8* (1)
PROTECTION DEGREE	IP65	IP65	IP67	IP67	IP65	IP67	IP67	IP67
DATA SHEET	K500		G200, G210, K500			G210, K500		G212, K500

(1) M8 connector SP-ZH-4P-M8/5 moulded on cable 5 mt lenght for pressure or force transducer (options /SL, /SP)  
 M8 connector SP-ZH-4P-M8/2-2 moulded with 2 cables, 2 mt lenght for 2 pressure transducers (options /SF)

connectors supplied with the valve

**16 INSTALLATION DIMENSIONS [mm]**

**ISO 4401: 2005**

**Mounting surface: 4401-05-04-0-05** (see table P005)  
**(for /Y version, surface: 4401-05-05-0-05 without X port)**

Fastening bolts:  
 4 socket head screws M6x40 class 12.9  
 Tightening torque = 15 Nm  
 Seals: 5 OR 2050; 1 OR 108  
 Diameter of ports A, B, P, T: Ø 11,2 mm (max)  
 Diameter of port Y: Ø 5 mm (only for /Y option)

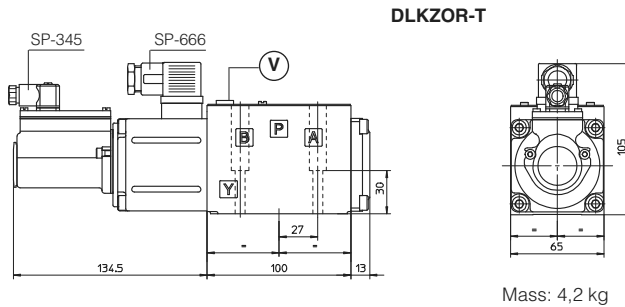

Note: for option /B the solenoid and the position transducer are at side of port A

Ⓧ = Air bleed off

**-TE EXECUTION**

① Dotted line = 12 poles connector SP-ZH-12P for option /Z

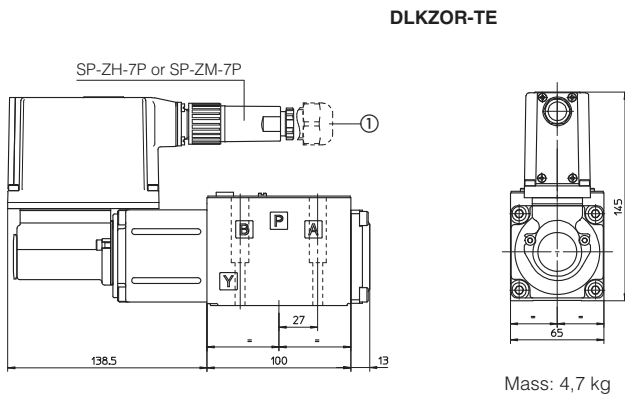

**-TES EXECUTION**

① Dotted line = 12 pin connector SP-ZH-12P for options /SF, /SL, /SP, /Z  
 ② Dotted line = M8 connector SP-ZH-4P-M8/5 moulded on cable 5 mt lenght for pressure or force transducer (options /SL, /SP)  
 M8 connector SP-ZH-4P-M8/2-2 moulded with 2 cables, 2 mt lenght for 2 pressure transducers (options /SF)

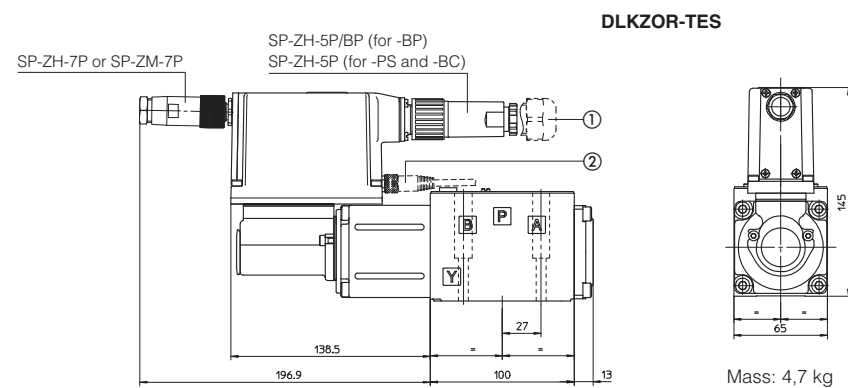

Note: for option /B the solenoid, the position transducer and the integral electronics are at side of port A

**17 MODEL CODES OF POWER SUPPLY AND COMMUNICATION CONNECTORS (to be ordered separately)**

VALVE VERSION	-T		-TE, -TES		-TE/Z	TES -PS, -BC	TES -BP	TES /SF, /SL, /SP
	Power supply	Transducer			-TES /Z, /SF, /SL, /SP			
CONNECTOR CODE	SP-666	SP-345	SP-ZH-7P	SP-ZM-7P	SP-ZH-12P	SP-ZH-5P	SP-ZH-5P/BP	SP-ZH-4P-M8/* (1)
PROTECTION DEGREE	IP65	IP65	IP67	IP67	IP65	IP67	IP67	IP67
DATA SHEET	K500		G200, G210, K500			G210, K500		G212, K500

(1) M8 connector SP-ZH-4P-M8/5 moulded on cable 5 mt lenght for pressure or force transducer (options /SL, /SP)  
 M8 connector SP-ZH-4P-M8/2-2 moulded with 2 cables, 2 mt lenght for 2 pressure transducers (options /SF)

connectors supplied with the valve