

# Proportional throttle cartridges type **LEQZO-A\***, 2-way

without position transducer, nominal sizes 16, 25 and 32

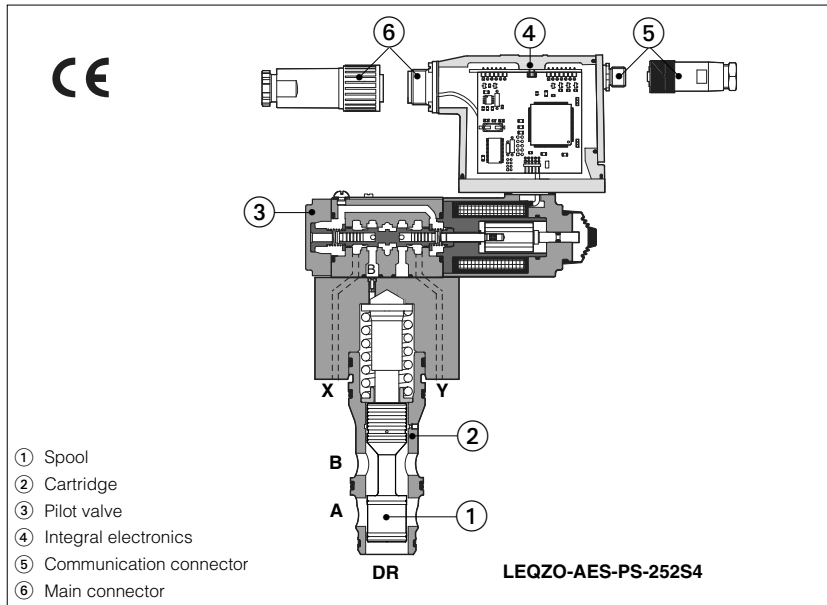

## 1 MODEL CODE

<b>LEQZO</b>	<b>- AES</b>	<b>- PS</b>	<b>- 25</b>	<b>2</b>	<b>S</b>	<b>4</b>	<b>/ *</b>	<b>**</b>	<b>/*</b>
Flow control valve									Synthetic fluids <b>WG</b> = water-glycol <b>PE</b> = phosphate ester
<b>A</b> = without position transducer <b>AE</b> = as A plus integral electronics <b>AES</b> = as A plus integral digital electronics								Series number	
Communication interfaces (only for AES) <b>PS</b> = Serial <b>BC</b> = CANopen <b>BP</b> = PROFIBUS DP								<b>Options for -A execution</b> , see section [5]: <b>6</b> = with 6 V <sub>DC</sub> coil instead of standard 12V <sub>DC</sub> coil <b>18</b> = with 18 V <sub>DC</sub> coil instead of standard 12V <sub>DC</sub> coil <b>Electronics options for -AE execution</b> , see section [7]: <b>I</b> = current reference input (4±20 mA) <b>Q</b> = enable signal <b>Electronics options for -AES execution</b> , see section [7]: <b>I</b> = current reference input (4±20 mA) <b>Z</b> = double power supply, enable, and fault and monitor signals (12 pin connector)	
Size: <b>16</b> <b>25</b> <b>32</b>									
<b>2</b> = 2 way									
Spool type <b>L</b> = linear <b>S</b> = progressive								Spool size: <b>4</b> = see section [8]	

LEQZO-A\* are 2-way proportional cartridge valves, designed for mounting in manifold blocks and provide not compensated flow control according to the electronic reference signal.

They operate in association with electronic drivers, see table [2] which supply the proportional valve with proper current to align valve regulation to the reference signal supplied to the electronic driver.

They are available in different executions:

- -A, without position transducer;
- -AE, -AES as -A plus analogue (AE) or digital (AES) integral electronics.

The regulation is operated by means of a spool ① sliding into a cartridge ② piloted by the proportional pressure reducing valve type DHRZO ③.

The integral electronics ④ ensures factory presetting, fine functionality plus valve-to-valve interchangeability and simplified wiring and installation.

The electronic main connector ⑥ is fully interchangeable for -AE and -AES executions.

Standard 7 pin main connector is used for power supply, analog input reference and monitor signals.

12 pin connector is used for AEG version and for option /Z (AES).

Following communication interfaces ⑤ are available for the digital -AES execution:

- -PS, RS232 serial communication interface. The valve reference signal is provided with analogue commands via the 7 (or 12) pins connector ⑥.
- -BC, CANbus interface
- -BP, PROFIBUS-DP interface

The valves with -BC and -BP interfaces can be integrated into a fieldbus communication network and thus digitally operated by the machine control unit.

The coils are fully plastic encapsulated (insulation class H), and the valves have antivibration, antishock and weather-proof features.

- Reduced response times
- Accurate flow regulation with good repeatability
- Sizes: 16, 25 and 32.
- Max flow up to 350 l/min with differential pressure Δp = 5 bar, see section [3].
- Max pressure: 250 bar.

## 2 ELECTRONIC DRIVERS FOR LEQZO

Valve model	-A						-AE	-AES
Drivers model	E-MI-AC-01F	E-MI-AS-IR	E-BM-AC-01F	E-BM-AS-PS	E-ME-AC-01F	E-RP-AC-01F	E-RI-AE	E-RI-AES
Data sheet	G010	G020	G025	G030	G035	G100	G110	G115

**Note:** For power supply and communication connector see section [16]

### 3 HYDRAULIC CHARACTERISTICS (based on mineral oil ISO VG 46 at 50 °C)

Hydraulic symbols						
Valve model	<b>LEQZO-A, LEQZO-AE, LEQZO-AES</b>					
Valve size	<b>16</b>		<b>25</b>		<b>32</b>	
Spool type and size	<b>S4</b>	<b>L4</b>	<b>S4</b>	<b>L4</b>	<b>S4</b>	<b>L4</b>
Max regulated flow at $\Delta p = 5$ bar at $\Delta p = 10$ bar	[l/min] 140 200		230 320		350 490	
Max pressure (1)	[bar] 250					
Response time 0 ÷ 100% step signal	[ms] 75					
Hysteresis	[% of max flow] $\leq 5\%$					
Repeatability	[% of max flow] $\pm 1\%$					

#### Notes:

- Above performance data refer to valves coupled with Atos electronic drivers, see section 2.
- 1) Minimum piloting pressure is 20 bar.

### 4 GENERAL NOTES

LEQZO proportional valves are CE marked according to the applicable Directives (e.g. Immunity/Emission EMC Directive).

Installation, wirings and start-up procedures must be performed according to the general prescriptions shown in table F003 and in the installation notes supplied with relevant components.

The electrical signals of the valve (e.g. monitor signals) must not be directly used to activate safety functions, like to switch-ON/OFF the machine's safety components, as prescribed by the European standards (Safety requirements of fluid technology systems and components-hydraulics, EN-982).

### 5 OPTIONS FOR -A EXECUTION

**5.1 Option /6** 6 Vdc coil instead of standard 12 Vdc, to be used in case of power supply 12 Vdc

**5.2 Option /18** 18 Vdc coil instead of standard 12 Vdc, to be used with electronic drivers not supplied by Atos

### 6 CONNECTIONS FOR -A EXECUTION

SOLENOID POWER SUPPLY CONNECTOR	
PIN	Signal description
<b>1</b>	SUPPLY
<b>2</b>	SUPPLY
<b>3</b>	GND

### 7 ANALOG INTEGRAL DRIVERS -AE - OPTIONS

Standard driver execution provides on the 7 pin main connector:

- Power supply** - 24Vdc must be appropriately stabilized or rectified and filtered; a 2,5 A safety fuse is required in series to the driver power supply. Apply at least a 10000  $\mu$ F/40 V capacitance to single phase rectifiers or a 4700  $\mu$ F/40 V capacitance to three phase rectifiers
- Reference input signal** - analog differential input with 0÷+10Vdc nominal range (pin D,E), proportional to desired coil current
- Monitor output signal** - analog output signal proportional to the actual valve's coil current (1V monitor = 1A coil current)

Following options are available to adapt standard execution to special application requirements:

#### 7.1 Option /I

It provides the 4÷20 mA current reference signal instead of the standard 0÷+10 Vdc. Monitor output signal is still the standard 0÷+10Vdc.

It is normally used in case of long distance between the machine control unit and the valve or where the reference signal can be affected by electrical noise; the valve functioning is disabled in case of reference signal cable breakage.

#### 7.2 Option /Q

It provides the possibility to enable or disable the valve functioning without cutting the power supply (the valve functioning is disabled but the driver current output stage is still active). To enable the driver supply a 24Vdc on the enable input signal.

#### 7.3 Possible combined option: /IQ

## 8 ANALOG INTEGRAL DRIVERS -AE - MAIN FUNCTIONS AND ELECTRONIC CONNECTIONS

**MAIN CONNECTOR  
7 PIN - STANDARD**

Selector SW				Dither frequency [Hz]
SW1	SW2	SW3	SW4	
				100
ON				130
	ON			160
		ON		<b>200 (Standard)</b>
ON		ON		230
	ON	ON		270
ON	ON	ON		300
ON	ON		ON	380
ON		ON	ON	430
	ON	ON	ON	470
ON	ON	ON	ON	500

The dither frequency is factory pre-set at 200 Hz and its regulation may be adjusted after contact with Atos technical department

**REGULATIONS AND SWITCHES**  
(remove the rear cover)

**B1:** positive bias adjust  
**S1:** positive scale adjust  
**RU:** ramp for increasing reference signal  
**RD:** ramp for decreasing reference signal  
**SW:** dither frequency selector (see table beside)

### 8.1 ELECTRONIC CONNECTIONS - 7 PIN MAIN CONNECTORS

PIN	SIGNAL	TECHNICAL SPECIFICATIONS	NOTES
A	V+	Power supply 24 Vdc for solenoid power stage and driver logic	Input - power supply
B	V0	Power supply 0 Vdc for solenoid power stage and driver logic	Gnd - power supply
C <sup>(1)</sup>	AGND	Ground - signal zero for MONITOR signal	Gnd - analog signal
	ENABLE	Enable (24 Vdc) or disable (0 Vdc) the driver (for /Q option)	Input - on/off signal
D	INPUT+	Reference analog input: 0÷+10 Vdc maximum range (4 ÷ 20 mA for /I option)	Input - analog signal
E	INPUT -	Normal working range 0÷+10 Vdc (4 ÷ 20 mA for /I option)	
F	MONITOR	Monitor analog output: 0÷+10 Vdc maximum range	Output - analog signal
G	EARTH	Internally connected to the driver housing	

**Note:** (1) with /Q option ENABLE signal replaces AGND on pin C; MONITOR signal is referred to pin B.

A minimum time of 60ms to 160ms have to be considered between the driver energizing with the 24 Vdc power supply and when the valve is ready to operate. During this time the current to the valve coils is switched to zero

## 9 DIGITAL INTEGRAL DRIVERS -AES - OPTIONS

Standard driver execution provides on the 7 pin main connector:

**Power supply** - 24Vdc must be appropriately stabilized or rectified and filtered; a 2,5 A safety fuse is required in series to each driver power supply. Apply at least a 10000 µF/40 V capacitance to single phase rectifiers or a 4700 µF/40 V capacitance to three phase rectifiers.

**Reference input signal** - analog differential input with 0÷+10 Vdc nominal range (pin D,E), proportional to desired coil current

**Monitor output signal** - analog output signal proportional to the actual valve's coil current (1V monitor = 1A coil current)

Following options are available to adapt standard execution to special application requirements:

### 9.1 Option /I

It provides 4÷20 mA current reference signal instead of the standard 0÷+10 Vdc. Monitor output signal is still the standard 0÷+10 Vdc

It is normally used in case of long distance between the machine control unit and the valve or where the reference signal can be affected by electrical noise; the valve functioning is disabled in case of reference signal cable breakage.

### 9.2 Option /Z

It provides on a 12 pin main connector the above standard features plus:

#### Logic power supply

Option /Z provides separate power supply for the solenoid (pin 1, 2) and for the digital electronic circuits (pin 9, 10).

Cutting solenoid power supply allows to interrupt the valve functioning but keeping energized the digital electronics thus avoiding fault conditions of the machine fieldbus controller. This condition allows to realize safety systems in compliance with European Norms EN13849-1 (ex EN954-1).

#### Enable Input Signal

To enable the driver, supply a 24Vdc on pin 3 referred to pin 2: when the Enable signal is set to zero the valve functioning is disabled (zero current to the solenoid) but the driver current output stage is still active. This condition does not comply with European Norms EN13849-1 (ex EN954-1).

#### Fault Output Signal

Fault output signal indicates fault conditions of the driver (solenoid short circuits/not connected, reference signal cable broken for 4÷20mA input, etc.). Fault presence corresponds to 0 Vdc, normal working corresponds to 24Vdc (pin 11 referred to pin 2): Fault status is not affected by the Enable input signal.

### 9.3 Possible combined option: /I/Z

## 10 DIGITAL INTEGRAL DRIVERS -AES - MAIN FUNCTIONS AND ELECTRONIC CONNECTIONS

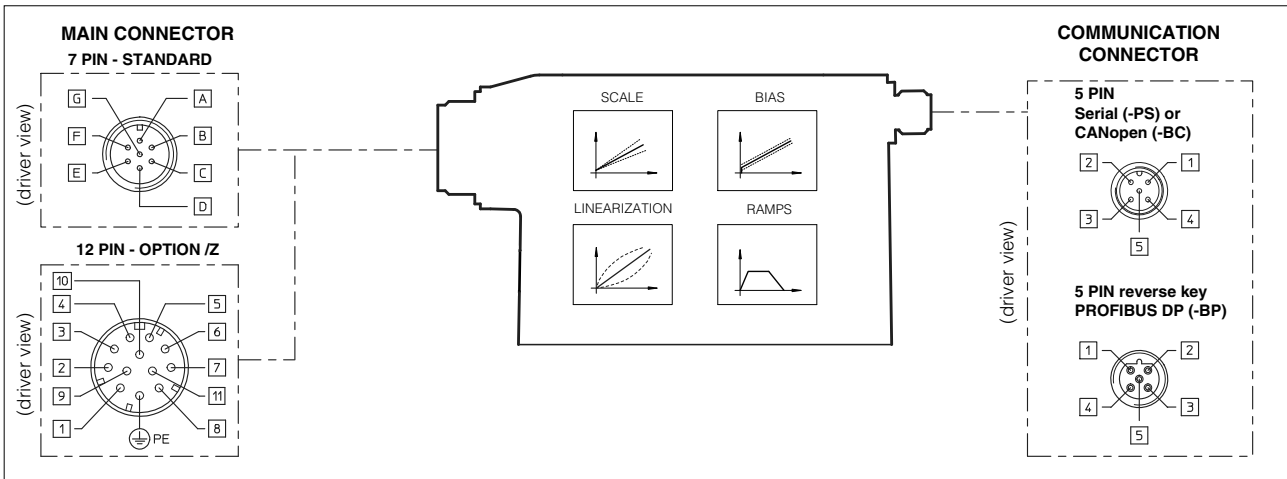

### 10.1 ELECTRONIC CONNECTIONS - 7 & 12 PIN MAIN CONNECTORS

Standard 7pin	/Z option 12pin	SIGNAL	TECHNICAL SPECIFICATIONS	NOTES
A	1	V+	Power supply 24 Vdc for solenoid power stage (and for driver logic on 7 pin connection)	Input - power supply
B	2	V0	Power supply 0 Vdc for solenoid power stage (and for driver logic on 7 pin connection)	Gnd - power supply
-	3	ENABLE	Enable (24 Vdc) or disable (0 Vdc) the driver	Input - on/off signal
D	4	INPUT+	Reference analog input: $\pm 10$ Vdc maximum range (4 $\div$ 20 mA for /I option)	Input - analog signal
E	-	INPUT -	Normal working range 0 $\div$ +10 Vdc (4 $\div$ 20 mA for /I option) standard: differential input; /Z option: common mode INPUT+ referred to AGND	
C	5	AGND	Ground - signal zero for MONITOR signal signal zero for INPUT+ signal (only for /Z option)	Gnd - analog signal
F	6	MONITOR	Monitor analog output: 0 $\div$ +10 Vdc maximum range	Output - analog signal
-	7	NC	do not connect	
-	8	NC	do not connect	
-	9	VL+	Power supply 24 Vdc for driver logic	Input - power supply
-	10	VLO	Power supply 0 Vdc for driver logic	Gnd - power supply
-	11	FAULT	Fault (0 Vdc) or normal working (24 Vdc)	Output - on/off signal
G	PE	EARTH	Internally connected to the driver housing	

**Note:** A minimum time of 270 to 340 ms have to be considered between the driver energizing with the 24Vdc power supply and when the valve is ready to operate. During this time the current to the valve coils is switched to zero.

### 10.2 ELECTRONIC CONNECTIONS - 5 PIN COMMUNICATION CONNECTORS

PIN	-PS Serial		-BC CANopen		-BP PROFIBUS DP	
	SIGNAL	TECHNICAL SPECIFICATION	SIGNAL	TECHNICAL SPECIFICATION	SIGNAL	TECHNICAL SPECIFICATION
1	NC	do not connect	CAN_SHLD	Shield	+5V	for termination
2	NC	do not connect	NC	do not connect	LINE-A	Bus line (high)
3	RS_GND	Signal zero data line	CAN_GND	Signal zero data line	DGND	data line and termination Signal zero
4	RS_RX	Valves receiving data line	CAN_H	Bus line (high)	LINE-B	Bus line (low)
5	RS_TX	Valves transmitting data line	CAN_L	Bus line (low)	SHIELD	

## 11 SOFTWARE TOOLS

The functional parameters of digital valves, as the bias, scale ramp and linearization of the regulation characteristic, can be easily set and optimized with the Atos E-SW programming software, available in three different versions according to the driver's communication interfacing: E-SW-PS (Serial), E-SW-BC (CANopen) and E-SW-BP (PROFIBUS DP).

A proper connection is required between the PC and the electronic driver communication port: for a more detailed description of software interface, PC requirements, adapters, cables and terminators, please see table G500.

Proportional valves with fieldbus communication interface (-BC and -BP) can be directly managed by the machine control unit; it is required to implement in the machine control the standard communication as described in the user manuals supplied with the relevant programming software. For detailed description of available fieldbus feature, see table G510.

On first supply of the E-SW software, it is required to apply for the registration in the Atos download area: [www.download.atos.com](http://www.download.atos.com)

Once the registration is completed, the password will be sent by email.

The software remains active for 10 days from the installation date and then it stops until the user inputs his password.

With the password you can also download, in your personal area, the latest releases of the Atos software, manuals, drivers and configuration files.

## 12 MAIN CHARACTERISTICS OF PROPORTIONAL RELIEF VALVES

Assembly position	Any position
Subplate surface finishing	Roughness index, $\sqrt{0.4}$ flatness ratio 0,01/100 (ISO 1101)
Ambient temperature	-20°C $\div$ +70°C for -A execution; -20°C $\div$ +60°C for -AE and -AES executions
Fluid	Hydraulic oil as per DIN 51524 ... 535 for other fluids see section 11
Recommended viscosity	15 $\div$ 100 mm <sup>2</sup> /s at 40°C (ISO VG 15 $\div$ 100)
Fluid contamination class	ISO 18/15 achieved with in line filters of 10 $\mu$ m and $\beta_{10} \geq 75$ (recommended)
Fluid temperature	-20°C +60°C (standard and /WG seals) -20°C +80°C (/PE seals)
Coil resistance R at 20°C	3 $\div$ 3.3 $\Omega$ for standard 12 Vdc coil; 2 $\div$ 2,2 $\Omega$ for 6 Vdc coil; 13 $\div$ 13,4 $\Omega$ for 18 Vdc coil
Max solenoid current	2,6 A for standard 12 Vdc coil; 3,25 A for 6 Vdc coil; 1,5 A for 18 Vdc coil
Max power	40 Watt
Protection degree (CEI EN-60529)	IP65 for -A execution; IP65 $\div$ 67 for -AE and AES executions, depending to the connector type see sect 16
Duty factor	Continuous rating (ED=100%)



