

Digital electronic drivers type E-MI-AS-IR

DIN 43650 plug-in format, for proportional valves without transducer

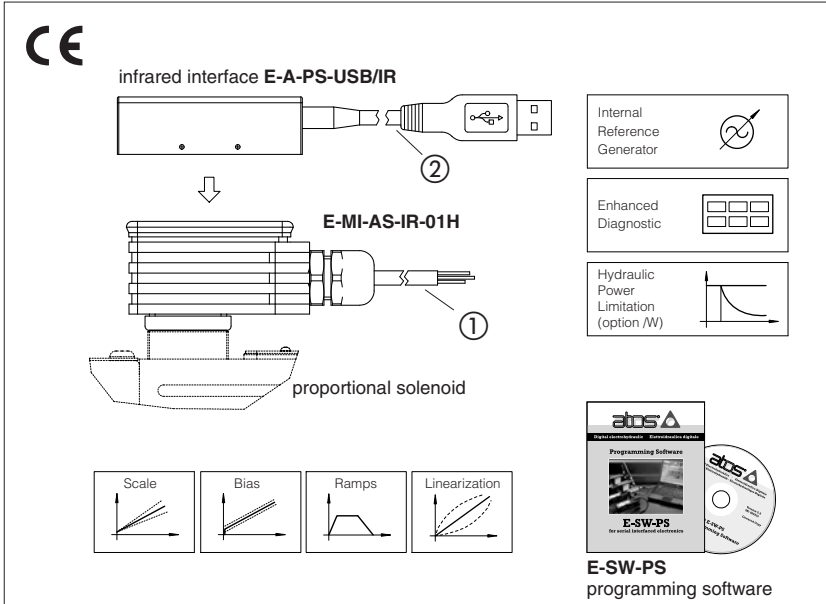

1 MODEL CODE

E - MI - A S - IR - 01H / * **

Electronic driver in plug-in format DIN 43650

A = driver for valves without transducer

S = digital execution

IR = Serial infrared communication interface

(1) SP-ZH-5P female connector must be ordered separately

Series number

Options, see section 4

- = standard version (with 5 m cable)

I = current reference input

M12 = with 5 poles M12 connector (1)

W = power limitation function (see 6.7)

01H = for single solenoid proportional valves

E-MI-AS digital drivers are designed for mounting on the solenoid's DIN connector of proportional valves without transducer. They supply and control the current to the solenoid according to the electronic reference input signal. The solenoid proportionally transforms the current into a force, acting on the valve spool or poppet, against a reacting spring, thus providing the valve's hydraulic regulation. E-MI-AS drivers can drive single or double solenoid proportional valve.

Electrical Features:

- Standard 5m cable connection ① or M12 connector (/M12 option)
- Infrared communication interface ② to program the driver with Atos PC software
- 2 leds for diagnostics: driver status and solenoid status
- +5 Vdc output supply for external reference potentiometer (not available for /M12 option)
- Current reference input (/I option)
- Plastic box with IP65 protection degree and standard DIN43650 plug-in format with double earth connection to allow double-side orientation
- CE mark to EMC directive

Software Features:

- Setting of valve's functional parameters: bias, scale, ramps, dither
- Linearization function for the hydraulic regulation
- 2 selectable modes for electronic reference signal: external analog input or internal generation
- Max power limitation (W option)
- Selectable range of electronic reference analog input: voltage or current (/I option)
- Complete diagnostics of driver status, solenoid and driver fault conditions
- Intuitive graphic interface

2 BLOCK DIAGRAM

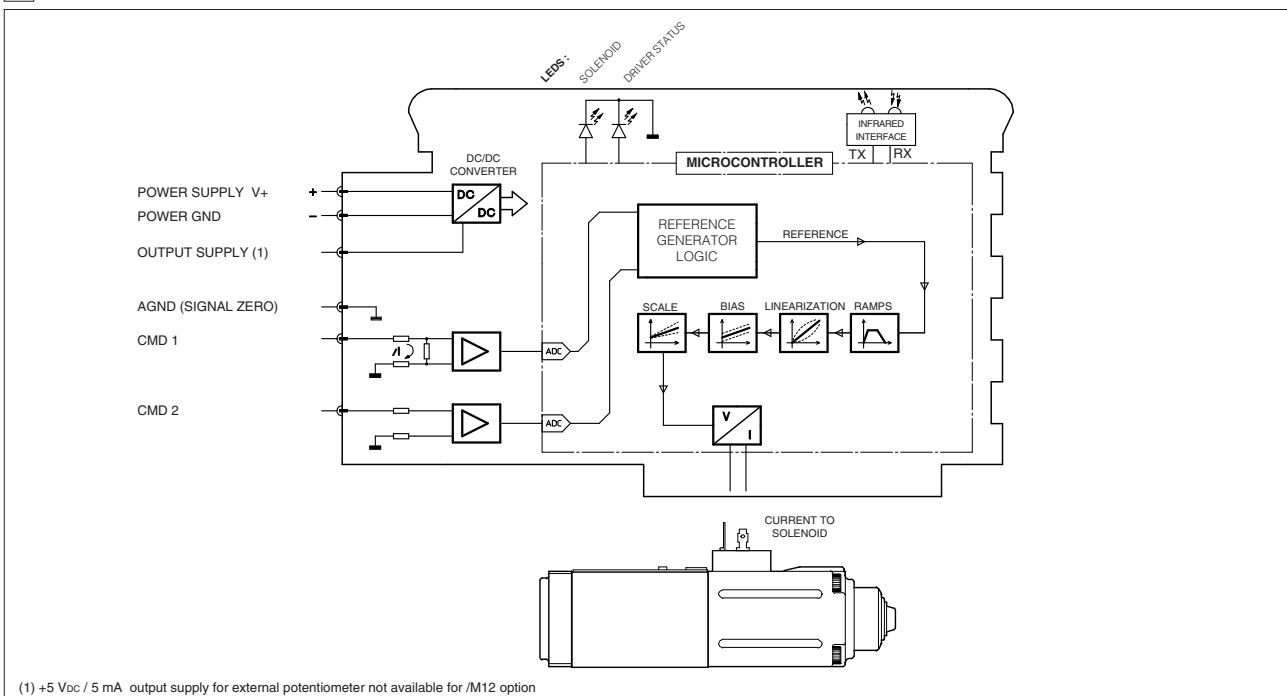

(1) +5 Vdc / 5 mA output supply for external potentiometer not available for /M12 option

3 MAIN CHARACTERISTICS OF E-MI-AS-IR ELECTRONIC DRIVERS

| | | |
|---|--|--|
| Power supply (see 4.1) | Nominal: +24 Vdc Nominal: +12 Vdc | Rectified and filtered: Vrms = 20 ÷ 27 VMAX (ripple max 10 % VPP) Rectified and filtered: Vrms = 10 ÷ 14 VMAX (ripple max 10 % VPP) |
| Max power consumption | 50 W | |
| Current supplied to solenoids | Imax = 2.7 A with +24 Vdc power supply to drive standard proportional valves (3,2 Ω solenoid) Imax = 3.3 A with +12 Vdc power supply to drive proportional valves with /6 option (2,1 Ω solenoid) | |
| Reference input signal (CMD1 - see 4.2) | Standard (voltage) Input range : 0 ÷ 10 Vdc /I option (current) Input range : 4 ÷ 20 mA / 0 ÷ 20 mA | Input impedance: Ri > 50 kΩ Input impedance: Ri = 500 Ω |
| Enable Input Signal (CMD2 - see 4.5) ON/OFF Input Signal (CMD1,CMD2 - see 4.6) | Input range: 0 ÷ 24 Vdc (OFF state: 0 ÷ 5Vdc ; ON state: 9 ÷ 24Vdc) Input impedance: Ri > 10 kΩ | |
| Pressure transducer input (CMD2 see 4.3) | /W option Input range : 0 ÷ 10 Vdc | Input impedance: Ri > 50 kΩ |
| Output supply (see 4.4) | +5 V @ max 5 mA : output supply for external potentiometer (not available for /M12 option) | |
| Alarms | Solenoid coil not connected, short circuit and cable break with current reference signal (/I option) | |
| Format | Plastic box ; IP65 protection degree (when fixed on solenoid) ; DIN43650 format | |
| Operating temperature | -20 °C ÷ +50 °C (storage -25 ÷ +85 °C) | |
| Mass | Standard version: 450 g ; /M12 option: 70 g | |
| Additional characteristics | Short circuit protection of current output to solenoid | |
| Electromagnetic compatibility (EMC) | According to Directive 2004/108/CE - Immunity: EN 61000-6-2 (2005) ; Emission: EN 61000-6-4 (2001) | |
| Communication interface | Infrared, Atos protocol with ASCII coding; E-A-PS-USB/IR adapter is required (see section 5) | |
| Wiring cable characteristics | 2 poles x 0,5 mm ² plus 4 poles x 0,35 mm ² , external diameter 7,4 mm | |

4 SIGNALS SPECIFICATIONS

4.1 Power supply and wirings

The power supply must be appropriately stabilized or rectified and filtered: apply at least a 10000 µF/40 V capacitance to single phase rectifiers or a 4700 µF/40 V capacitance to three phase rectifiers.
A safety fuse is required in series to each driver power supply: 2,5 A fuse (4 A fuse when 12Vdc power supply is applied)

4.2 Reference Input Signal (CMD1: yellow/pin 4, referred to AGND: white/pin 3)

The driver proportionally transforms the external reference signal input into the current supplied to the solenoid.
The driver is designed to receive one analog reference input (CMD1 on yellow/pin 4) referred to the analog electric ground (AGND on white/pin3) and with a maximum range of 0 ÷ 10 Vdc . Internal reference generation is software selectable (see 6.6).

Option /I (current reference input)

The reference input signal maximum range is software selectable among current 4 ÷ 20 mA (with cable break detection) or 0 ÷ 20 mA.

4.3 Pressure Input Signal (CMD2: blue/pin 5, /W option)

When hydraulic power limitation is active (see 6.7), enable input (CMD2) is managed as an analog input and has to be connected to an external pressure transducer installed on the hydraulic system; maximum input range 0 ÷ 10 Vdc.

4.4 Output supply for external potentiometer - (OUTPUT SUPPLY: green, referred to AGND: white) not available for /M12 option

The reference analog signal can be generated by an external potentiometer directly connected to the driver, using the +5Vdc supply output available at green wire thus generating the desired reference signal.

4.5 Enable Input Signal (CMD2: blue/pin 5, referred to AGND: white/pin 3)

Enable input signal allows to enable/disable the current supply to the solenoid, without removing the electrical power supply to the driver; it is used to maintain active the infrared connection and the other driver functions when the valve must be disabled for safety reasons.

To enable the driver, supply a 24Vdc on CMD2 (blue/pin 5, referred to white/pin 3). The polarity of the enable input can be customized and the enable function can be deactivated, see table at side.

4.6 ON/OFF Input Signals (CMD1: yellow/pin 4, CMD2: blue/pin 5)

When the driver is configured in internal reference generation mode (see 6.6), both reference input (CMD1) and enable input (CMD2) are managed as ON/OFF input signals. In this mode they are used to select the active reference signal, among the available stored values.

4.7 Possible combined options: /IM12, /IM12W, /IW and /M12W.

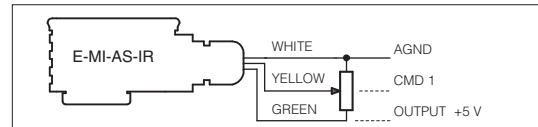

| ENABLE CONFIGURATION | | | |
|----------------------|------------------|------------------|-------------|
| Signal | default polarity | reverse polarity | deactivated |
| 9 ÷ 24 Vdc | solenoid ON | solenoid OFF | solenoid ON |
| 0 ÷ 5 V | solenoid OFF | solenoid ON | solenoid ON |

5 SOFTWARE TOOLS

The driver configuration and parameters can be easily set with the **E-SW-PS** programming software.
The **E-A-PS-USB/IR** dedicated adapter (usb to infrared) is required between the PC and the electronic driver
For a more detailed description of software interface, PC requirements and adapter characteristics please refer to tab. **G500**.

Programming software, must be ordered separately :

E-SW-PS (mandatory - first supply) = Dvd including E-SW-PS software installer and operator manuals; it allows the registration to Atos digital service
E-SW-PS-N (optional - next supplies) = as above but not allowing the registration to Atos digital service

On first supply of the E-SW-PS software, it is required to apply for the registration in the Atos download area : www.download.atos.com .

Once the registration is completed, the password will be sent by email.

The software remains active for 10 days from the installation date and then it stops until the user inputs his password.

With the password you can also download, in your personal area, the latest releases of the Atos software, manuals, drivers and configuration files.

Adapter, must be ordered separately

E-A-PS-USB/IR = adapter from USB connector (PC communication port) to driver infrared communication interface: plug the adapter on the driver to establish the infrared communication

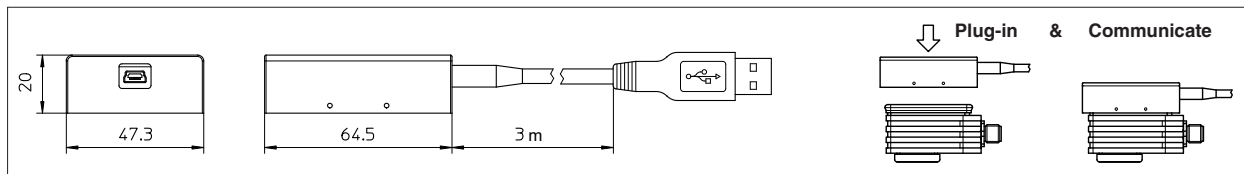

6 MAIN SOFTWARE PARAMETER SETTINGS

The following is a brief description of the main settings and features of E-MI-AS drivers.

For a detailed descriptions of all available settings, wirings and installation procedures, please refer to the programming manuals E-MAN-MI-AS included in the E-SW-PS Dvd (see section 5)

6.1 Scale

Scale function allows to set the maximum current supplied to the solenoid, corresponding to the max valve regulation, at maximum reference signal value.

This regulation allows to adapt the maximum current supplied from the driver to the specific nominal current of the proportional valves to which the driver is coupled; it is also useful to reduce the maximum valve regulation in front of maximum reference signal.

6.1, 6.2 - Scale, Bias & Threshold

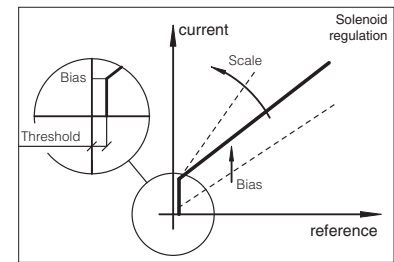

6.2 Bias and Threshold

Proportional valves may be provided with a dead band in the hydraulic regulation corresponding to their switch-off status.

This dead band discontinuity in the valve's regulation can be compensated by activating the Bias function, which adds a fixed preset Bias value to the reference signal (external input or internally generated).

The Bias function is activated when the reference signal overcome the Threshold value, preset into the driver.

The Bias setting allows to calibrate the Bias current supplied to the solenoid of the specific proportional valve to which the driver is coupled.

The Threshold setting is useful to avoid undesired valve regulation at zero reference signal when electric noise is present on the analog input signal: smaller threshold reduces the reference signal dead band, greater values are less affected by electric noise presence.

If internal reference generation is active (see 6.6), threshold should be set to 0.

6.3 - Ramps

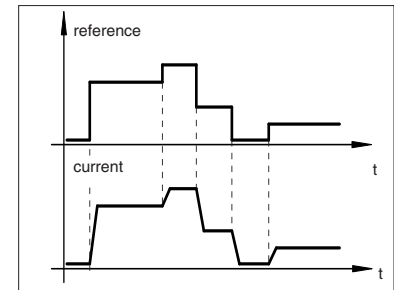

6.3 Ramps

The ramp generator allows to convert sudden change of electronic reference signal into smooth time-dependent increasing/decreasing of the current supplied to the solenoid.

Different ramp mode can be set:

- single ramp for any reference variation
- two ramps for increasing and for decreasing reference variations

Ramp generator is useful for application where smooth hydraulic actuation is necessary to avoid machine vibration and shocks.

If the proportional valve is driven by a closed loop controller, the ramps can lead to unstable behaviour, for these applications ramp function can be software disabled (default setting)

6.4 - Dither

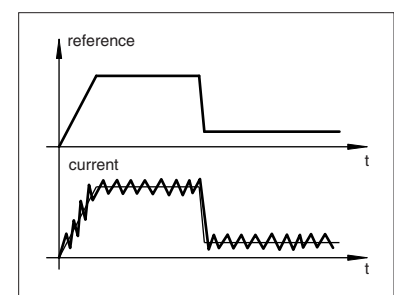

6.4 Dither

The dither is an high frequency modulation of the current supplied to the solenoid, to reduce the hysteresis of the valve's regulation: a small vibration in the valve's regulating parts considerably reduces static friction effects.

Dither frequency can be set in a range from 80 to 500 Hz (default value is 200Hz).

Lower dither setting reduces the hysteresis but also reduces the regulation stability. In some application this can lead to vibration and noise: right setting usually depends on system setup.

Default dither is a valid setting for a wide range of hydraulic applications

6.5 Linearization

Linearization function allows to set the relation between the reference input signal and the current supplied to the solenoid.

Linearization is useful for applications where it is required to linearize the valve's regulation in a defined working condition (e.g. maximum pressure control at defined working flow)

6.5 - Linearization

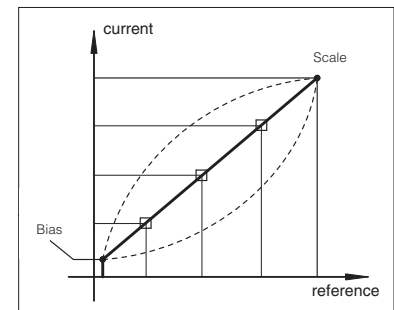

6.6 Internal Reference Generation

Internal generation of reference values is software selectable.

In this mode the 2 driver inputs (see 4.6) allow to select the desired solenoid current reference signal, among the different internal stored values: external control unit can thus manage complex machine profile by simple switching of the reference signal, by 2 digital inputs (see 4.6).

Each digital input combination corresponds to a different reference value; up to 4 different internal values are available:

| | Internal generated references | | | |
|------|-------------------------------|--------|--------|--------|
| | REF1 | REF2 | REF3 | REF4 |
| CMD1 | 0 | 24 Vdc | 24 Vdc | 0 |
| CMD2 | 0 | 0 | 24 Vdc | 24 Vdc |

A different ramp time value can be set by software for each available stored reference value.

6.6 - Internal Reference Generation

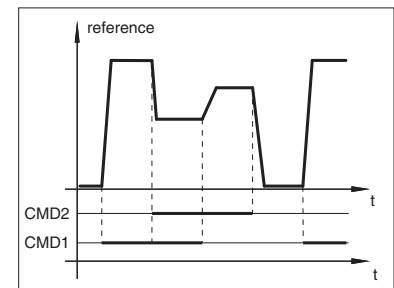

6.7 Hydraulic Power Limitation (option /W)

E-MI-AS drivers with /W option electronically perform hydraulic power limitation on single solenoid valves:

- flow control valves (direct and pilot operated)
- directional control valves (direct and pilot operated) + mechanical pressure compensator
- variable displacement pumps with proportional flow regulator (e.g. PVPC-*-LQZ, tab. A170)

The driver receives the flow reference signal by the analog external input CMD1 (see 4.2) and a pressure transducer, installed in the hydraulic system, has to be connected to the driver's analog input CMD2 (see 4.3).

When the actual requested hydraulic power $p \times Q$ (CMD2 x CMD1) reaches the max power limit ($p1 \times Q1$), internally set by software, the driver automatically reduces the flow regulation of the valve. The higher is the pressure transducer feedback the lower is the valve's regulated flow:

$$\text{Flow regulation} = \text{Min} \left(\frac{\text{PowerLimit [sw setting]}}{\text{Transducer Pressure [CMD2]}} ; \text{Flow Reference [CMD1]} \right)$$

6.7 - Hydraulic Power Limitation

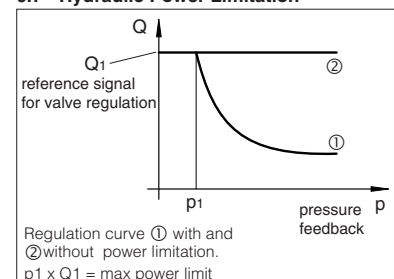

Regulation curve ① with and ② without power limitation.
 $p1 \times Q1 = \text{max power limit}$

7 DRIVER CONNECTIONS

| Standard cable wire color | /M12 option pin | SIGNAL | TECHNICAL SPECIFICATIONS | NOTES |
|---------------------------|-----------------|--------------------|--|------------------------|
| RED | 1 | V+ | Power supply +24 V _{DC} or +12 V _{DC} (see 4.1) | Input - power supply |
| BLACK | 2 | V0 | Power supply 0 V _{DC} | |
| WHITE | 3 | AGND (Signal zero) | Ground for CMD1,CMD2 and OUTPUT SUPPLY | Input - analog signal |
| GREEN | N.A. | OUTPUT SUPPLY | +5 V _{DC} @ 5 mA output supply for external potentiometer (not available for option /M12) (see 4.4) | Output - analog signal |

The two input signals CMD1 and CMD2 can be managed as analog input or ON/OFF signals; their function depends on the selected software setting:

| Standard cable wire color | /M12 option pin | SIGNAL | TECHNICAL SPECIFICATIONS (software setting dependent) | | | NOTES |
|---------------------------|-----------------|--------|---|--|---|---------------------------|
| | | | Default (see 4.2 : 4.5) | Internal Reference Generation (see 4.6 ; 6.6) | Hydraulic Power Limitation (only for /M option - see 4.3 : 6.7) | |
| YELLOW | 4 | CMD 1 | Reference analog input: 0 ÷ 10 V _{DC} (4 ÷ 20 mA; 0 ÷ 20 mA for /I option) | ON/OFF: 24 V _{DC} / 0 V _{DC} | Reference analog input: 0 ÷ 10 V _{DC} (4 ÷ 20 mA; 0 ÷ 20 mA for option /I) | Input - analog or digital |
| BLUE | 5 | CMD 2 | Enable/disable the driver: 24V _{DC} / 0V _{DC} | ON/OFF: 24 V _{DC} / 0 V _{DC} | Pressure transducer input: 0 ÷ 10 V _{DC} | |

8 DOUBLE SOLENOID VALVES OPERATION

It is possible to use two E-MI-AS drivers to operate one double solenoid proportional valve supplying the same analog signal to both CMD1 inputs reference. The enable input signal is used to select which driver/solenoid has to be active.

To operate double solenoid valves it is required to:

- parallel wire the two drivers (see following scheme).
- select opposite polarity (default and reverse) for the two enable signals (see 4.5)
- manage from PLC or machine unit: 1 analog reference signal corresponding to desired valve's regulation and 1 ON/OFF signal to select the active solenoid.

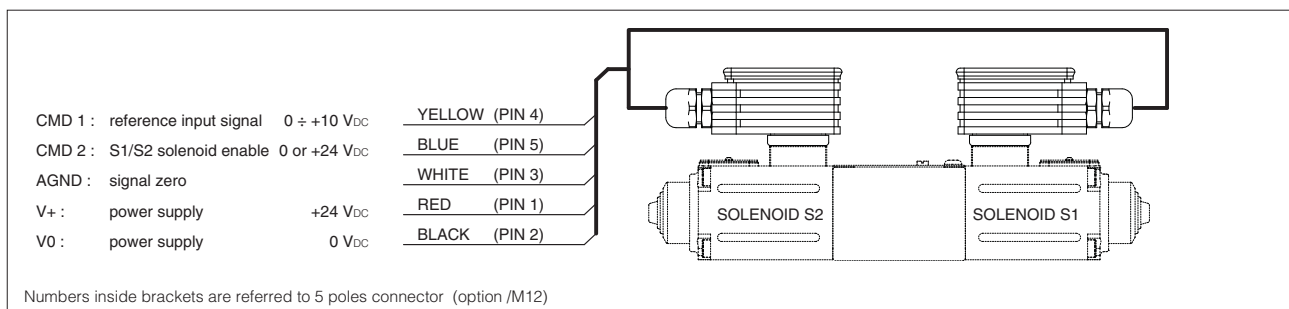

9 DIAGNOSTIC LEDS

It is possible to verify the actual status of solenoid command (yellow LED) and the driver status (green LED). The following table details the possible displayed conditions:

| COIL (YELLOW LED) | |
|------------------------|----------------------------------|
| Light signal displayed | Coil status |
| Light Off | PWM command OFF |
| Light On | PWM command ON |
| Slow blinking | Solenoid not connected |
| Fast blinking | Short circuit on the solenoid |
| STATUS (GREEN LED) | |
| Light signal displayed | Driver status |
| Light Off | Absence of power supply |
| Light On | Malfunctioning |
| Slow blinking | Driver disabled or Alarm present |
| Fast blinking | Driver enabled |

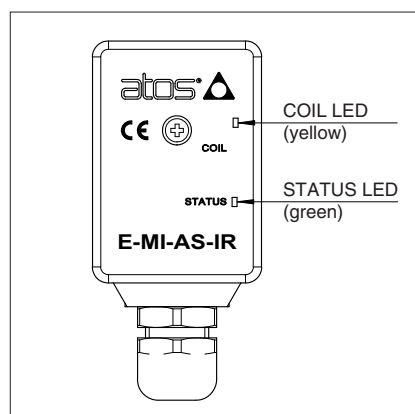

10 DIMENSIONS [mm] AND INSTALLATION

