

Electronic drivers type E-ME-L

analog, Eurocard format, for proportional valves with two transducers

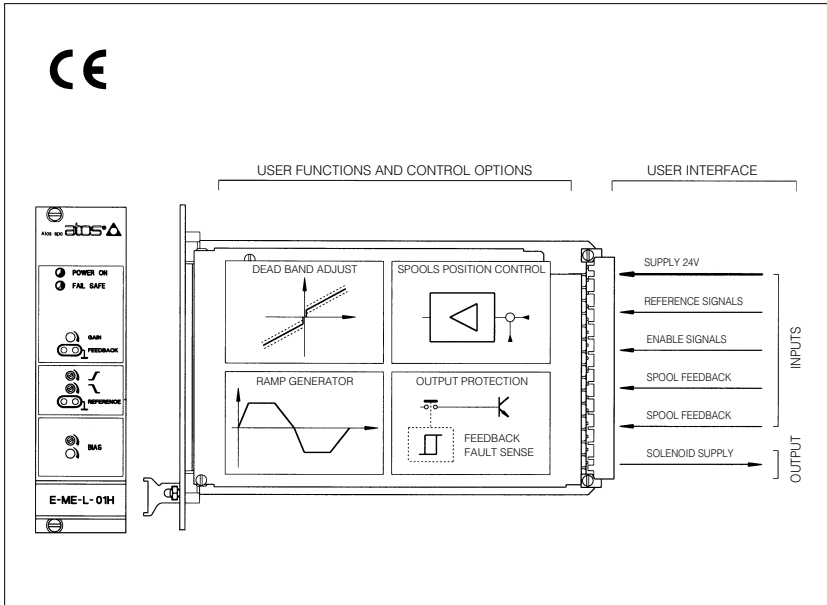

E-ME-L drivers control the current to the solenoid of Atos proportional valves with position transducer, regulating the spool position or the flow according to the electronic reference signal, adjusted by transducers's feedbacks.

Features:

- bias regulation
- scale and dissymmetrical ramps regulation
- voltage (standard) or current (/I option) reference signal
- voltage (standard) or current (/C option) feedback signal
- test point for reference and feedback control on front panel
- factory pre-setted
- Eurocard format (DIN 41494 - plug-in unit)
- electronic filters on input and output lines
- CE marking granting the conformity to the EMC Directive (Electromagnetic compatibility)
- both sides of the card with shielded cover with E faston connector

Applications:

Position or flow open or closed-loop regulation systems, according to the block diagram [2].

1 MODEL CODE

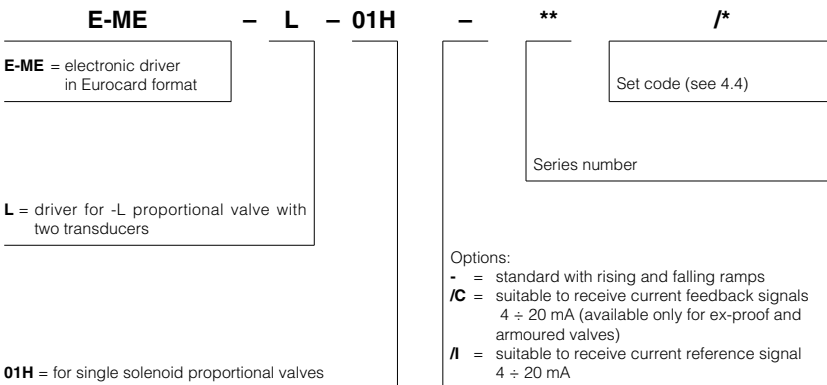

2 BLOCK DIAGRAM

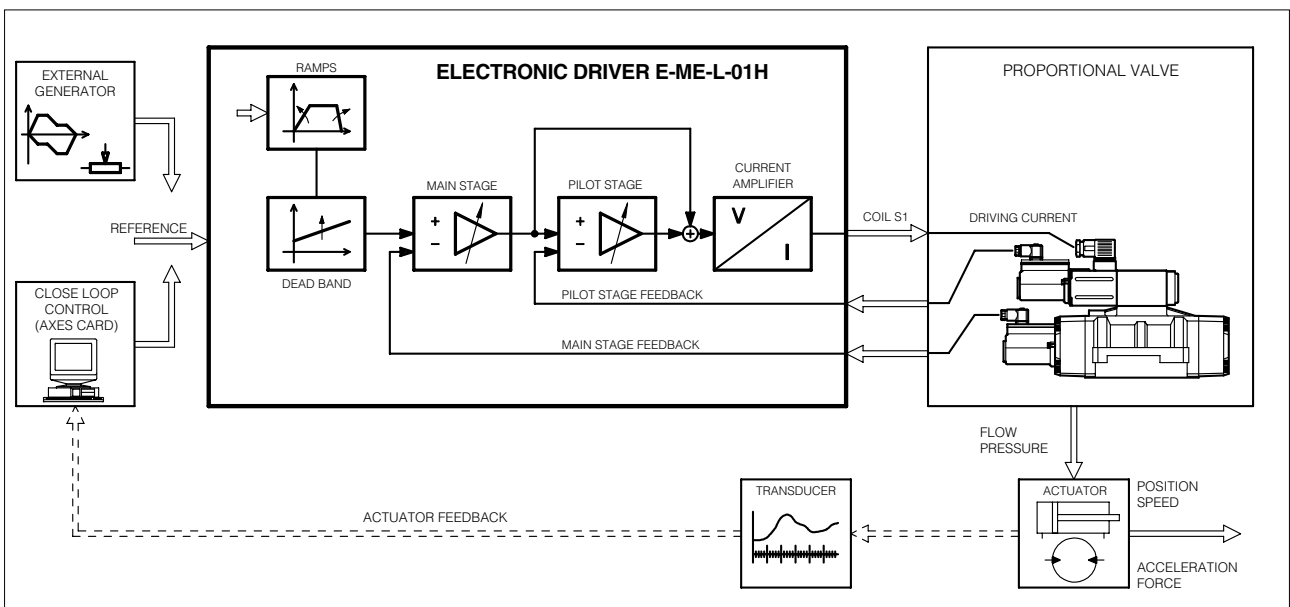

3 MAIN CHARACTERISTICS OF E-ME-L ELECTRONIC DRIVERS

Power supply (positive at contacts 2a, 2c) (negative at contacts 4a, 4c)	Nominal : 24 V _{DC} Rectified & filtered : V _{RMS} = 21 ÷ 33 (max ripple = 2Vpp)
Max power consumption	50 W
Current supplied to solenoid	I _{max} = 3.3A square wave PWM type
Nominal reference signal, factory preset	E-ME-L-01H : 0 ÷ 10 V at contact 12c (GND on 16ac) (± 10 V option see 4.2) for /I option : 4 ÷ 20 mA at contact 12c (+) and 8a (-)
Reference signal variation range, (internal scale adjust option)	± 10 V (SW pos. 1) and ± 5 V (SW pos. 2) 0 ÷ 10 V (0 ÷ 5 V) for valves with one external position (DPZO-L-*5, LIQZO-L-**2)
Input signal impedance	Voltage R _i > 50 KOhm - (/I option R _i = 316 Ohm)
Potentiometers supply	+10 V / 10 mA at contact 10c and -10 V / 10 mA at contact 14c
Ramp time	14 sec. max (0 ÷ 100% of reference signal)
Enabling signal	V = 5 ÷ 24 V _{DC} on contact 8c with led indicator on panel
Electrical wiring	Coil : 2 x 1 mm ² to 20 m 2 x 1,5 mm ² shielded to 40 m Transducer : 4 x 0,25 mm ² to 20 m 4 x 0,5 mm ² shielded to 40 m
Card format	Europe 100x160 mm (Plug in unit DIN 41494)
Card connector	Male DIN 41612 /D
Connector elements available	Type E-K-32M frame snap connector (see table G800) to be ordered separately
Operating temperature	0 ÷ 50 °C (storage -20 ÷ +70 °C)
Front panel dimensions	128,4 x 35,3 mm
Weight	520 gr.
Features	Position control by PID action - Rapid solenoid excitation and switching off - Outputs to solenoids protected against accidental short circuits - Feedback cable break produces an inhibit of the driver, zeroing the current and creating a fail-safe position in the valve.

4 GENERAL SPECIFICATIONS

4.1 Power supply and wirings

The power supply must be appropriately stabilized or rectified and filtered. If the power supply is generated by a single phase rectifier, use a 10000µF/40V capacitor; if pulse voltage is generated by a three phase rectifier connect a 4700µF/40V capacitor (see [1]).

Connect the reference signal to the main electronic control by means of shielded and twisted cables. Pay attention: the negative and the positive poles must not be exchanged each other. Shield the wirings to avoid electromagnetic noise (EMC).

It is suitable to keep the driver and its cables far from any electromagnetic radiation source (like cables where high currents flow, electric motors, transformers, relays, solenoids, portable radio-transmitter, etc.).

Wire the earth connection as shown in [1], according to CEI EN 60204-1 standards.

Connect the shield of the driver to the noiseless earth terminal (TE) [3].

4.2 Reference signal

The electronic driver is designed to receive external voltage or current reference signals according to [5].

Note that drivers suitable to receive current reference (option /I) have signal values in the range 4 to 20mA. For single solenoid valves with two external positions (*60), the reference signal is symmetrical ±10 V (±5 V).

4.3 Enabling signal

The digital signal on contact 8c allows to enable (24 V_{DC}) or disable (0 V) the driver without switching off the power supply; use this signal to cyclically inhibit the driver or in emergency conditions

4.4 Set code

Basic calibration of the electronic driver is factory preset according to proportional valve it has to be coupled with. These pre-calibrations are identified by a standard number in the model code as follow:

DPZO-L-15*	= DL15SA	DPZO-L-370*/B	= DL36SB
DPZO-L-15*/B	= DL15SA	DPZO-L-37*	= DL37SB
DPZO-L-160/170	= DL16SA	DPZO-L-37*/B	= DL37SB
DPZO-L-17*	= DL17SA	DPZO-L-65*	= DL65SA
DPZO-L-17*/B	= DL17SA	DPZO-L-660/670	= DL66SA
DPZO-L-25*	= DL25SB	DPZO-L-67	= DL67SA
DPZO-L-25*/B	= DL25SB	LIQZO-L-162L4	= LQ12SA
DPZO-L-260*	= DL26SB	LIQZO-L-252L4	= LQ22SB
DPZO-L-270*	= DL26SB	LIQZO-L-253L4	= LQ23SB
DPZO-L-260*/B	= DL26SB	LIQZO-L-322L4	= LQ32SA
DPZO-L-270*/B	= DL26SB	LIQZO-L-323L4	= LQ33SA
DPZO-L-27*	= DL27SB	LIQZO-L-402L4	= LQ42SB
DPZO-L-27*/B	= DL27SB	LIQZO-L-403L4	= LQ43SA
DPZO-L-35*	= DL35SB	LIQZO-L-502L4	= LQ52SB (*)
DPZO-L-35*/B	= DL35SB	LIQZO-L-503L4	= LQ53SB (*)
DPZO-L-360*	= DL36SB	LIQZO-L-632L4	= LQ62SC (*)
DPZO-L-370*	= DL36SB	LIQZO-L-633L4	= LQ63SC (*)
DPZO-L-360*/B	= DL36SB	LIQZO-L-802L4	= LQ82SC (*)
		LIQZO-L-803L4	= LQ83SD (*)
		LIQZO-L-10002	= LQ92SC (*)

(*) These codes have the main stage transducer connection different from standard (see [11], [12] - connection type B)

For **ex-proof valves**, insert an "A" in the fifth digit of the code adjustment; for example, the code adjustment for DPZA-L-15* is DL15AA (see table E120).

4.5 Calibrations/settings available to the user, see [7], [8], [9], [10].

Scale, see [7]

The Scale regulation, available on the card side, permits to modify the relation between the reference signal and the position or the regulated flow.

Modifying this regulation it is possible to fit the valve hydraulic behaviour to the effective system conditions; in addition the two regulations available for positive and negative reference signals permit to set different hydraulic adjustments for positive and negative movements.

The Scale regulation is factory set in order to control the max valve opening with 100% of the reference signal (10 V).

5 EXTERNAL REFERENCE SIGNALS

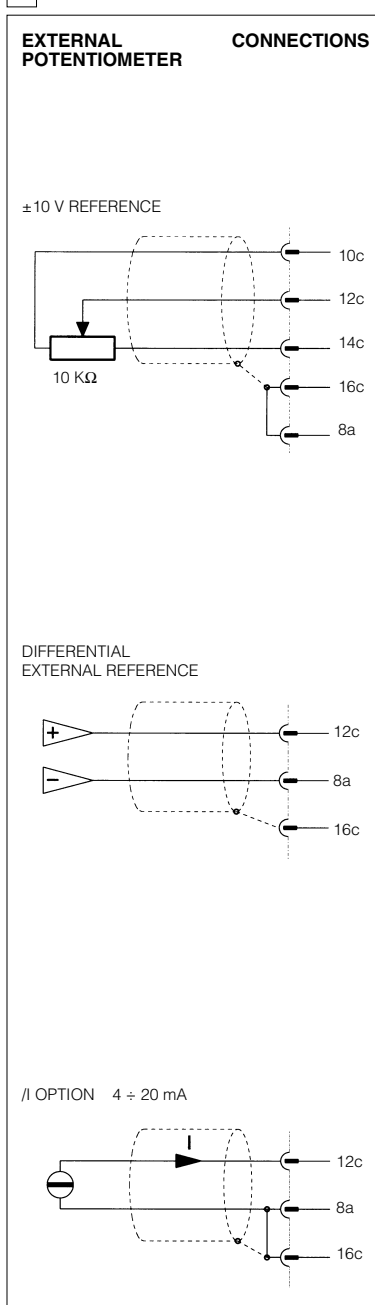

Bias (dead band compensation)

The bias regulations, available on the front panel (P1), permit to set the correspondence between the electrical zero of the reference signal with the beginning of the valve's hydraulic regulation, compensating the dead band and the component's mechanical tolerances .
Modifying this regulation (see [9]) it is possible to fit the valve hydraulic behaviour to the effective system conditions.

This regulation is factory set at the standard values depending to the proportional valve to be controlled and it is identified by the driver set code (see 4.4)

Ramps, see [7], [11].

The ramp regulation, available on the front panel, permit to modify the time in which the valve reaches the set opening value in front of a step change of the reference signal.

The ramp regulation is factory set at value close to zero and it can be increased up to 14 sec max for a step change of the reference signal from 0% to 100%.

The two available regulations P3 and P4 permit to respectively regulate the ramp times for positive and negative variations of the reference signal. In case of application of the driver in closed loop systems, it is advisable to disable the ramp function: it is possible to permanently disable this function by means of a switch on the card side ([7]) or temporarily, connecting the pin 6c and 6a ([12])

6 INSTALLATION AND START-UP

6.1 Warning

- Do not insert or remove the driver while the electronic system is energized.
- Connect the electronic driver according to the desired connection diagram (see [10], [11])
- The voltages must be always measured in reference to the GND (pin 16a of the connector).
- Refer to [8] to identify components mentioned in the setting procedure.
- To check the reference signal and the regulated valve opening , use the test points T1 and T2 on the front panel.

6.2 Start-up

Factory preset adjustments may not meet the desired requirements for the specific application and performances can be optimized by on-site re-adjustments of bias, scale and ramps potentiometers, in sequence. It is advisable to perform calibration procedures in the order given below.

Bias adjustment (dead band compensation), see [8], [9], [10].

- Supply a reference signal voltage = 0V_{cc}.
- Gradually turn bias potentiometer P1 until a movement of the controlled actuator is obtained.
- Turn slowly in the opposite sense, until stop is obtained.

Scale adjustment see [7], [9], [10].

Factory preset reference signal is ± 10V (selector in position 1). If a 0 ÷ 5V (± 5V) reference signal is available, set selector in position 2 (see [7]-A).

- Only in particular cases when a non standard reference signal is available it is possible to adjust maximum valve opening with scale regulation proceeding as follow :
- supply max reference signal voltage (repeat for max negative voltage) in the specified range and turn counterclockwise internal scale potentiometers P5 and P6 (factory preset to 100%) to reduce valve opening (see [7]-C).

Ramps (see [7], [8])

If the card is being used in an open loop system push the switch from position ramp off (standard) to ramp on, (see [7]-B). Calibrate the ramp settings only if dynamic impacts and tendencies towards instability persist after optimizations of the whole system. Adjust the ramp settings using the ramp potentiometers (P3 and P4) until the phenomenon has been eliminated (Clockwise rotation = increase in ramp time).

8 E-ME-L-01H TOPOGRAPHICAL VIEW OF REGULATIONS

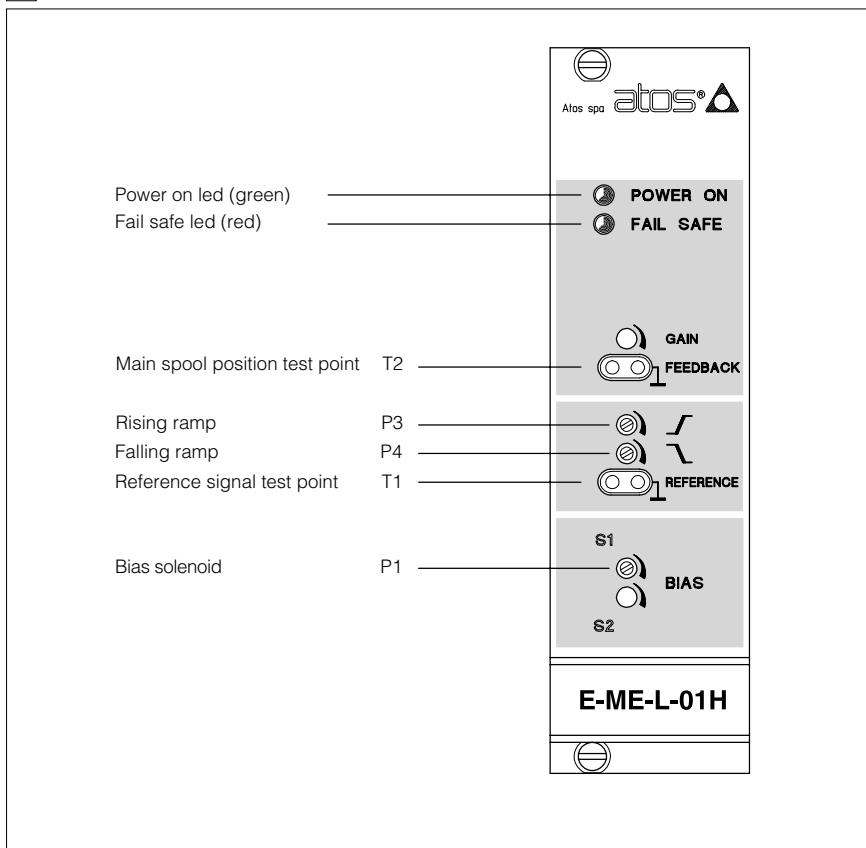

7 RAMPS AND SETTINGS

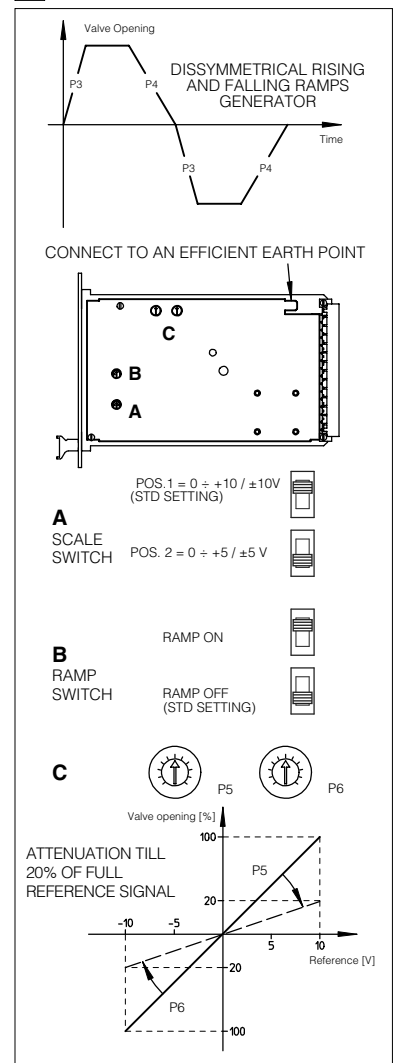

9 E-ME-L-01H DIAGRAM

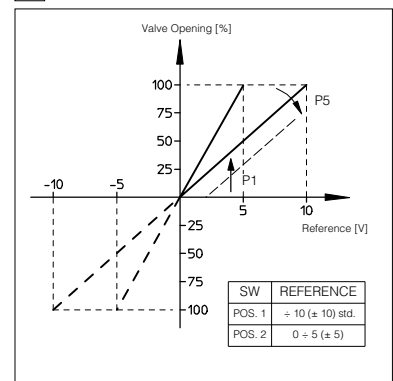

10 IMPORTANT INSTRUCTIONS

ELETTROMAGNETIC COMPATIBILITY

Atos electronic drivers and proportional valves are designed according to the 2004/108/CE Directive (Electromagnetic Compatibility) and according to EN 50081-2 (Emission) and EN 50082-2 (Immunity) standards. The electromagnetic compatibility of electronic drivers is valid only for wirings realized according to the typical electric connections shown in this technical table.

The device must be verified on the machine because the magnetic field may be different from the test conditions.

SAFETY

The electrical signals (for example reference signals, feedback and enable signal) of electronic drivers must not be used to realize safety conditions of the machine. This is in accordance with the provisions of european directives (Safety requirements of fluid technology systems and components-hydraulics, EN 982). Special attention must be paid to switch-on/switch-off of electronic drivers because they could produce uncontrolled movements of actuators operated by the proportional valves.

11 WIRING BLOCK DIAGRAM

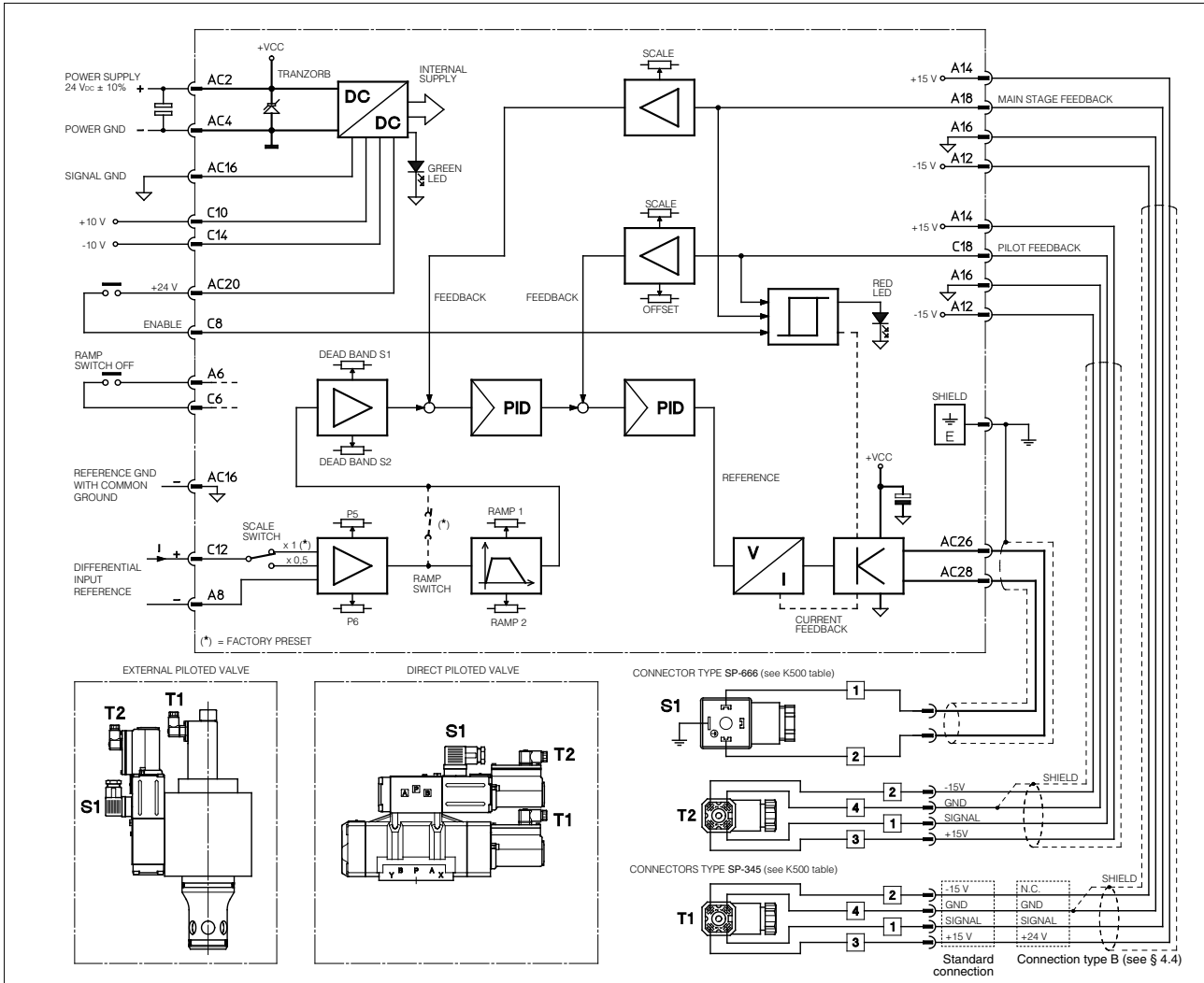

12 GENERAL CONNECTIONS

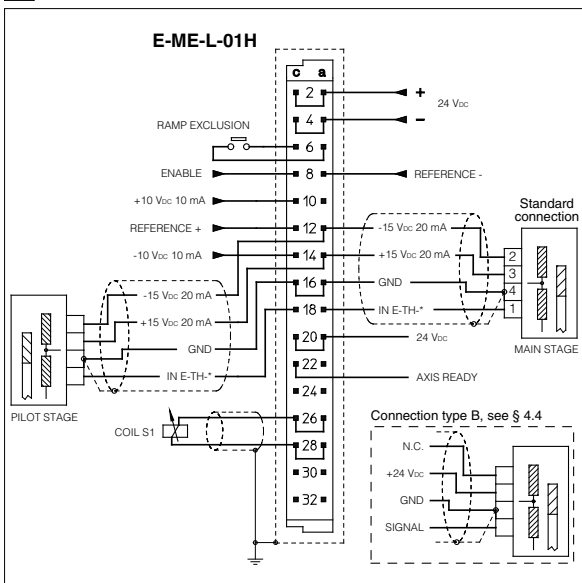

13 EARTH CONNECTIONS

