

Analog electronic drivers type E-RI-TE, E-RI-LE

integral-to-valve format, for proportional valves with one or two spool position transducers

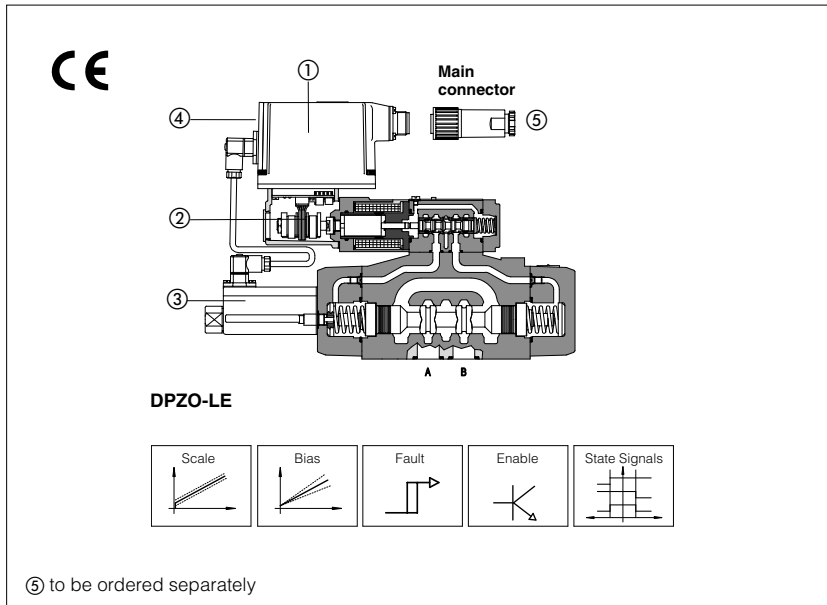

These integral analog drivers ① supply and control, in closed loop, the position of the spool or poppet of direct and pilot operated proportional valves according to the electronic reference input signal.

E-RI-TE execution operates direct and pilot operated directional/flow control valves with one integral spool position transducer ②.

E-RI-LE execution operates directional pilot operated valves with two integral spool position transducer ② and ③.

Features:

- Integral-to-valve analog electronic, factory preset for best performances
- Potentiometer adjustment ④ of the hydraulic zero, bias and scale
- Standard 7 pin main connector ⑤ for power supply, analog input reference and monitor signals
- /Z option 12 pin main connector for additional enable and fault signals
- /K option 12 pin main connector for additional enable and logic state signals
- IP67 protection degree
- CE mark to EMC directive

1 MODEL CODE

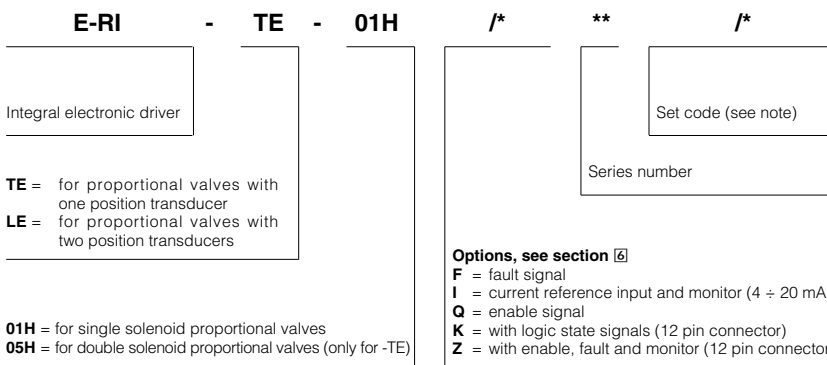

Note: the set code identifies the correspondance between the integral driver and the relevant valve; it is assigned by Atos when the driver is ordered as spare part.

2 BLOCK DIAGRAM

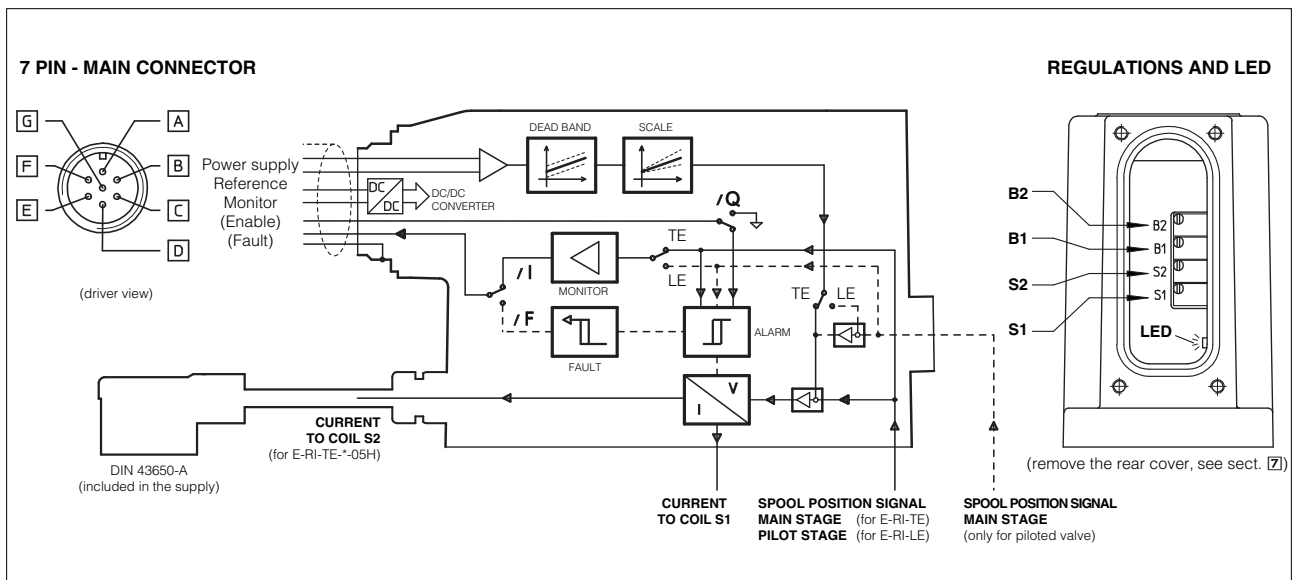

3 BLOCK DIAGRAM - /Z AND /K options

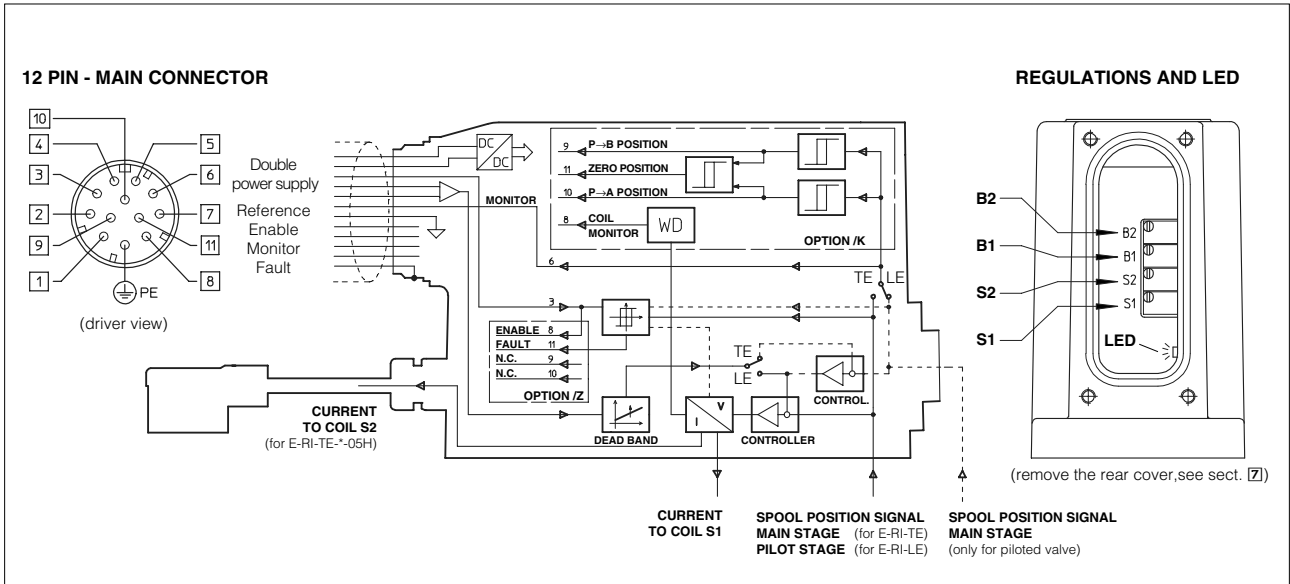

4 ELECTRONIC CONNECTIONS - 7 PIN MAIN CONNECTOR

PIN	SIGNAL	TECHNICAL SPECIFICATIONS	NOTES
A	V+	Power supply 24 Vdc for solenoid power stage and driver logic	Input - power supply
B	V0	Power supply 0 Vdc for solenoid power stage and driver logic	Gnd - power supply
C ⁽¹⁾	AGND	Ground - signal zero for MONITOR signal	Gnd - analog signal
	ENABLE	Enable (24 Vdc) or disable (0 Vdc) the driver (for /Q option)	Input - on/off signal
D	INPUT+	Reference analog differential input: ± 10 Vdc maximum range ($4 \div 20$ mA for /I option) For single solenoid valves the reference input is $0 \div +10$ Vdc ($4 \div 20$ mA for /I option)	Input - analog signal
E	INPUT -	For double solenoid valves the reference input is ± 10 Vdc ($4 \div 20$ mA for /I option)	
F ⁽²⁾	MONITOR	Monitor analog output: ± 10 Vdc maximum range ($4 \div 20$ mA for /I option)	Output - analog signal
	FAULT	Fault (0V) or normal working (24V) (for /F option)	Output - on/off signal
G	EARTH	Internally connected to the driver housing	

Notes (1) with /Q option ENABLE signal replaces AGND on pin C; MONITOR signal is referred to pin B
 (2) with /F option FAULT signal replaces MONITOR on pin F.

A minimum time of 20ms to 120ms have be considered between the driver energizing with the 24 Vdc power supply and when the valve is ready to operate. During this time the current to the valve coils is switched to zero

5 ELECTRONIC CONNECTIONS - 12 PIN MAIN CONNECTOR

PIN	SIGNAL option /Z	SIGNAL option /K	TECHNICAL SPECIFICATIONS	NOTES
1	V+		Power supply 24 Vdc for solenoid power stage and driver logic	Input - power supply
2	V0		Power supply 0 Vdc for solenoid power stage and driver logic	Gnd - power supply
3	ENABLE		Enable (24 Vdc) or disable (0 Vdc) the driver	Input - on/off signal
4	INPUT+		Reference analog differential input: ± 10 Vdc maximum range ($4 \div 20$ mA for /I option) For single solenoid valves the reference input is $0 \div +10$ Vdc ($4 \div 20$ mA for /I option)	Input - analog signal
5	INPUT -		For double solenoid valves the reference input is ± 10 Vdc ($4 \div 20$ mA for /I option)	
6	MONITOR		Monitor analog output: ± 10 Vdc maximum range ($4 \div 20$ mA for /I option)	Output - analog signal
7	AGND		Ground - signal zero for MONITOR signal	Gnd - analog signal
8	R_ENABLE	COIL OFF	Repeat Enable - output repetition of Enable input (see 6.5, for /K option)	Output - on/off signal
9	NC	P → B	do not connect (see 6.5, for /K option)	Output - on/off signal
10	NC	P → A	do not connect (see 6.5, for /K option)	Output - on/off signal
11	FAULT	ZERO	Fault (0V) or normal working (24V) (see 6.5, for /K option)	Output - on/off signal
PE	EARTH		Internally connected to the driver housing	

Notes A minimum time of 20ms to 120ms have be considered between the driver energizing with the 24 Vdc power supply and when the valve is ready to operate. During this time the current to the valve coils is switched to zero

6 OPTIONS

Standard driver execution provides on the 7 pin main connector:

- Power supply** - 24Vdc must be appropriately stabilized or rectified and filtered; a 2,5 A safety fuse is required in series to the driver power supply. Apply at least a 10000 μ F/40 V capacitance to single phase rectifiers or a 4700 μ F/40 V capacitance to three phase rectifiers
- Reference input signal** - analog differential input with ± 10 Vdc nominal range (pin D,E), proportional to desired valve spool position
- Monitor output signal** - analog output signal proportional to the actual valve's spool position with ± 10 Vdc nominal range

Atos drivers are CE marked according to the applicable directives (e.g. Immunity/Emission EMC Directive).

Installation, wirings and start-up procedures must be performed according to the general prescriptions shown in table F003.

The electrical signals of the valve (e.g. monitor signals) must not be directly used to activate safety functions, like to switch-ON/OFF the machine's safety components, as prescribed by the European standards (Safety requirements of fluid technology systems and components-hydraulics, EN-982)

Following options are available to adapt standard execution to special application requirements:

6.1 Option /F

It provides a Fault output signal in place of the Monitor output signal, to indicate fault conditions of the driver (cable interruption of spool transducers or reference signal - for /I option): Fault presence corresponds to 0 Vdc, normal working corresponds to 24 Vdc

6.2 Option /I

It provides the 4 \pm 20 mA current reference and monitor signals instead of the standard ± 10 Vdc

It is normally used in case of long distance between the machine control unit and the valve or whenever the reference signal can be affected by electrical noise; the valve functioning is disabled in case of reference signal cable breakage

6.3 Option /Q

It provides the possibility to enable or disable the valve functioning without cutting the power supply (the valve functioning is disabled but the driver current output stage is still active). To enable the driver, supply a 24Vdc on the enable input signal

6.4 Option /Z

This option includes /F and /Q features, plus the Monitor output signal.

When the driver is disabled (0 Vdc on enable signal) fault output is forced to 0 Vdc

6.5 Option /K (only for direct operated double solenoid valves with positive overlap)

This option provides, by means of four ON/OFF output signals, a real time monitor of the valve's hydraulic regulation (P-A, P-B or Central) and of the solenoid energizing status.

It can be used to improve the system safety level, by interfacing the four signals to a specific CE certified electronics: beside the standard safety valves the machine CNC can also recognize the proportional valve regulation during the working cycle.

The valve regulation is identified by the contemporaneous status on the four signals, as shown in the beside diagram. The central position indicates no hydraulic regulation: "central position window" is located across the valve's mechanical zero within $\pm 5\%$ of the total stroke and it provides a reliable information about the actuator stopped condition (valve's spools have a nominal positive overlap of $\pm 20\%$ of total stroke). The signal on pin 8 identifies the solenoid energizing status and depends on enable signal status (see 6.3): "0" = coil current active and "1" = coil current zero (enable signal must be 0Vdc).

For all signals, the logic state "0" produces an output voltage signal ≤ 1 Vdc while the logic state "1" produces an output voltage signal ≥ 22 V

State Signals

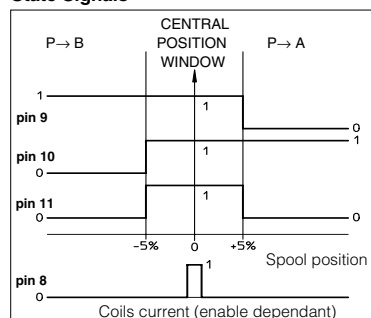

6.6 Possible combined options: /F1, /IK and /IZ

7 REGULATIONS AND LED

Remove the 4 screws ① of driver's rear cover to access the regulations adjustments and diagnostic led.

Diagnostic led indicates the presence of driver's fault conditions (cable interruption of spool transducers and, only for /I option, cable interruption of reference signal):

- Normal working = LED turned off
- Fault presence = LED turned on

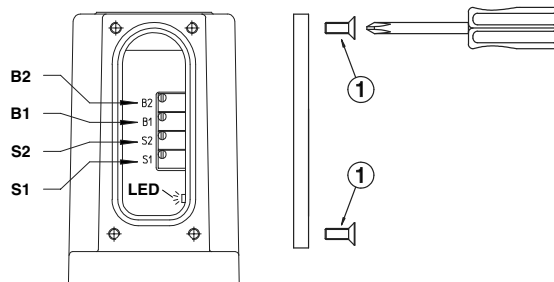

Single solenoid directional control valve, two positions and with positive overlapping

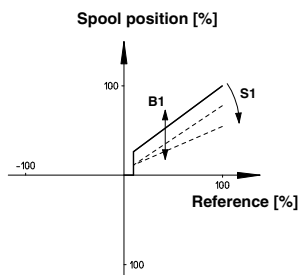

B1 bias adjust
S1 scale adjust

Threshold = 2% (200mV or 0.32mA for /I option)

Double solenoid directional control valve, three position with positive overlapping

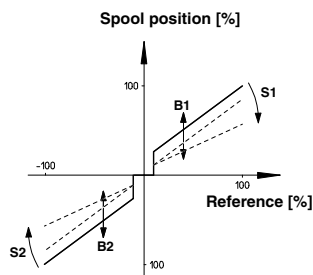

B1 positive bias adjust
S1 positive scale adjust
B2 negative bias adjust
S2 negative scale adjust

Threshold = 2% (± 200 mV or ± 0.16 mA for /I option)

Single or double solenoid directional control valve, three position, zero overlapping

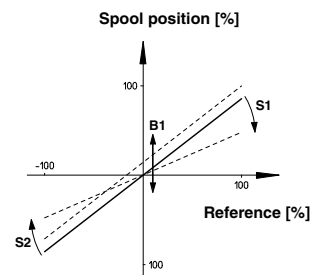

B1 bias adjust
S1 positive scale adjust
S2 negative scale adjust

8 DRIVER CHARACTERISTICS

Power supply	Nominal: +24 Vdc Rectified and filtered: $V_{rms} = 20 \div 32 V_{MAX}$ (ripple max 10 % V_{PP})
Max power consumption	50 W
Reference input signal	Input impedance: voltage $R_i > 50 \text{ k}\Omega$ (range $\pm 10 \text{ Vdc}$) current $R_i = 316 \Omega$ (range $4 \div 20 \text{ mA}$)
Monitor output	Output range : voltage $\pm 10 \text{ Vdc}$ @ max 5mA current $4 \div 20 \text{ mA}$ @ max 500 Ω load resistance
Enable input	Input impedance: $R_i > 10 \text{ k}\Omega$; range : $0 \div 5 \text{ Vdc}$ (OFF state), $9 \div 24 \text{ Vdc}$ (ON state), $5 \div 9 \text{ Vdc}$ (not accepted)
Fault output	Output range : $0 \div +24 \text{ Vdc}$ (ON state > power supply-2V ; OFF state < 1V) @ max 50mA
Alarms	cable break with current reference signal and valve spool trasducer cable break
Format	Sealed box on the valve; IP67 protection degree
Operating temperature	$-20 \div 60 \text{ }^\circ\text{C}$ (storage $-20 \div 70 \text{ }^\circ\text{C}$)
Mass	approx. 445g
Additional characteristics	Short circuit protection of solenoid's current supply; spool position control by P.I.D. with rapid solenoid switching
Electromagnetic compatibility (EMC)	According to Directive 2004/108/CE (Immunity: EN 50082-2; Emission: EN 50081-2)
Calibrations	remove the rear cover to access bias and scale regulations
Recommended wiring cable	LiYCY shielded cables: $0,5 \text{ mm}^2$ for length up to 40m [$1,5 \text{ mm}^2$ for power supply and solenoid]

9 MAIN CONNECTOR CHARACTERISTICS (to be ordered separately)

CODE	SP-ZH-7P	SP-ZM-7P	SP-ZH-12P
Type	Female straight circular socket plug 7pin	Female straight circular socket plug 7pin	Female straight circular socket plug 12pin
Standard	DIN 43563-BF6-3-PG11	According to MIL-C-5015 G	DIN 43651
Material	Plastic reinforced with fiber glass	Aluminium alloy with cadmiun plating	Plastic reinforced with fiber glass
Cable gland	PG11	PG11	PG16
Cable	LiYCY 7x 0,75 mm ² max 20 m 7 x 1 mm ² max 40 m	LiYCY 7x 0,75 mm ² max 20 m 7 x 1 mm ² max 40 m	LiCY 10 x 0,14 mm ² (signal) LiYY 3 x 1 mm ² (alimentation)
Connection type	to solder	to solder	to crimp
Protection (DIN 40050)	IP 67	IP 67	IP 65

10 OVERALL DIMENSIONS [mm]

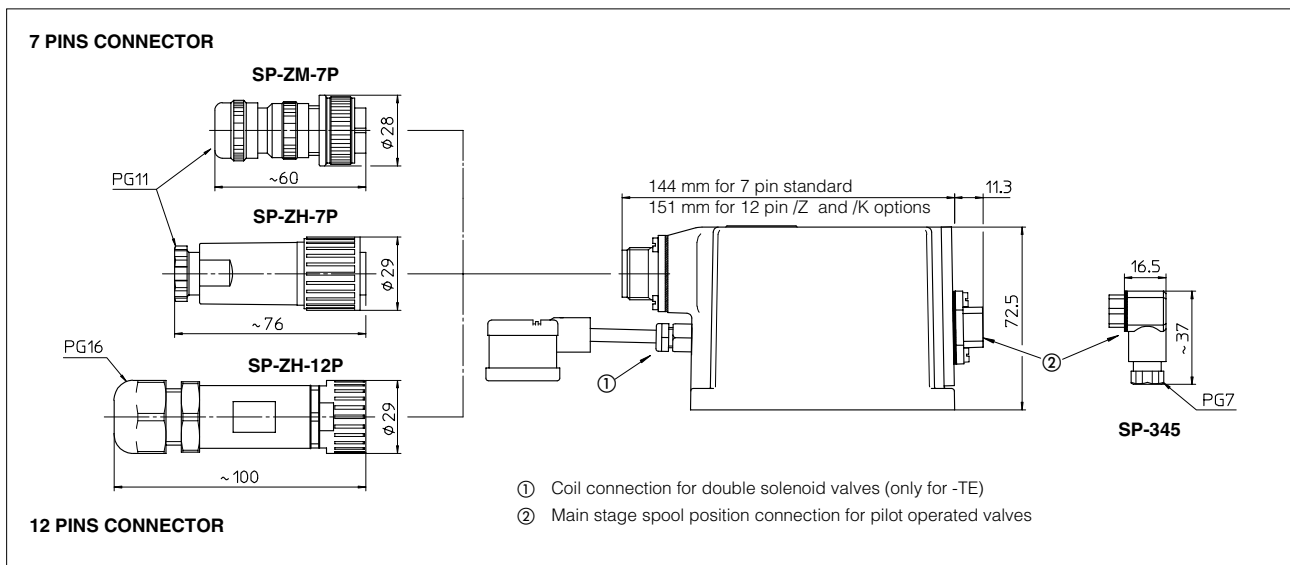

Note: female plug connectors to be ordered separately