

# Digital electronic drivers type E-RI-TERS, E-RI-AERS

integral-to-valve format, for proportional valves with one integral or remote pressure transducer

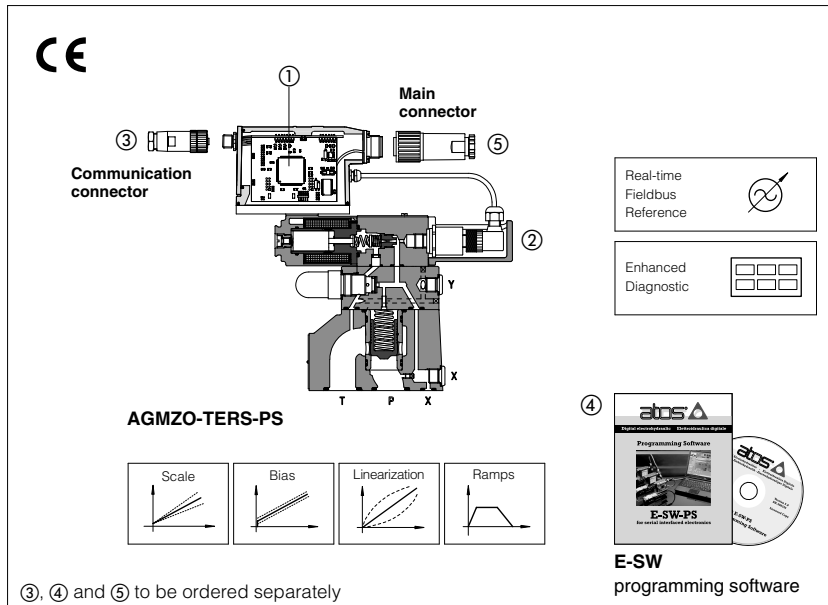

These integral digital drivers ① supply and control, in closed loop, the regulated pressure of direct and pilot operated proportional valves according to the electronic reference input signal.

E-RI-TERS execution operates direct and pilot operated relief/reducing control valves with one integral pressure transducer ②.

E-RI-AERS execution operates direct and pilot operated relief/reducing control valves with one remote pressure transducer.

Digital communication interface ③ allows to program the drivers with the Atos PC software ④.

Drivers executions with fieldbus communication interface (CANopen or PROFIBUS DP) are available to program and command the valves directly by the machine control unit.

### Electrical Features:

- Functional parameters are factory preset for best performances
- Standard 7 pin main connector ⑤ for power supply, analog input reference and monitor signals
- /Z option 12 pin main connector for additional double power supply, enable and fault signals
- /I option for current reference and monitor signals
- /C option for current interface with remote pressure transducer
- 5 pin connector ③ for communication interface, at choice: serial -PS or fieldbus -BC and -BP
- IP67 protection degree
- CE mark to EMC directive

### Software Features:

- Setting of valve's functional parameters: bias, scale, ramps, dither
- Linearization function for the hydraulic regulation
- Setting of valve's dynamic response (PID) to optimize the application performances
- Range selection for the electronic reference analog inputs: voltage or current (/I option)
- Complete diagnostics of driver status, solenoid and fault conditions
- Intuitive graphic interface

## 1 MODEL CODE

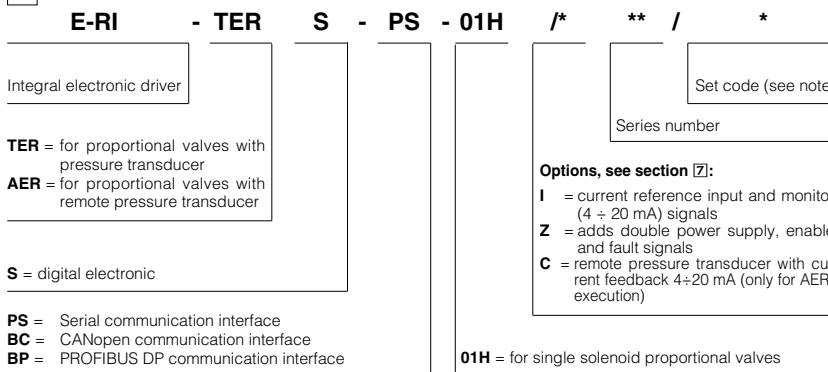

**Note:** the set code identifies the correspondance between the digital integral driver and the relevant valve; it is assigned by Atos when the driver is ordered as spare a part.

## 2 BLOCK DIAGRAM

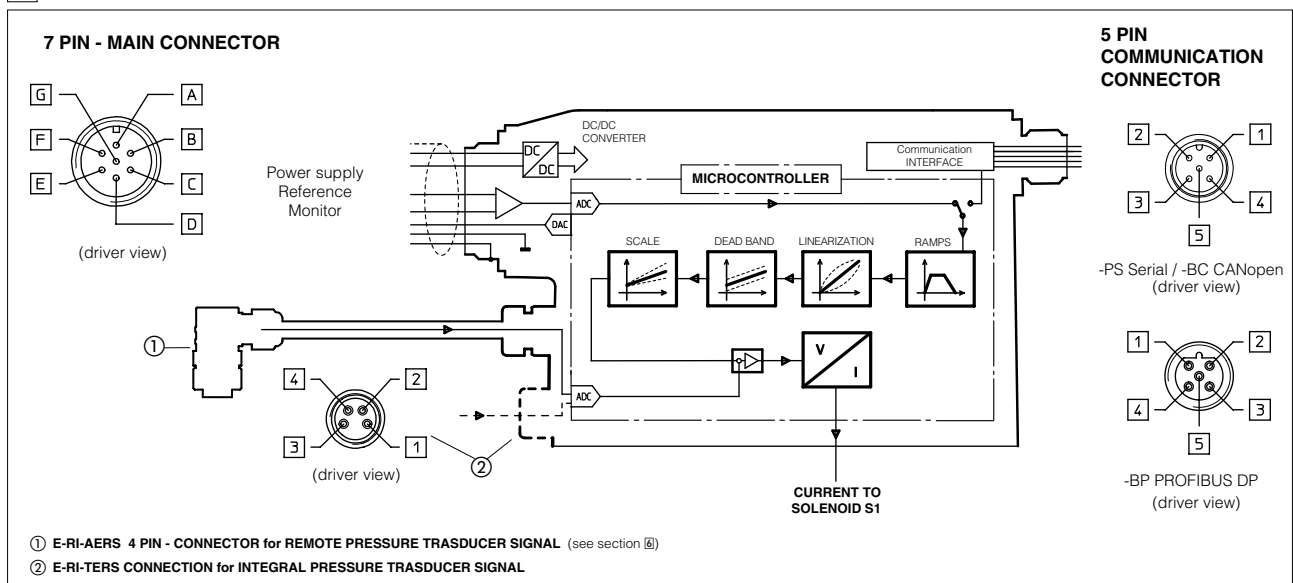

### 3 BLOCK DIAGRAM - /Z option

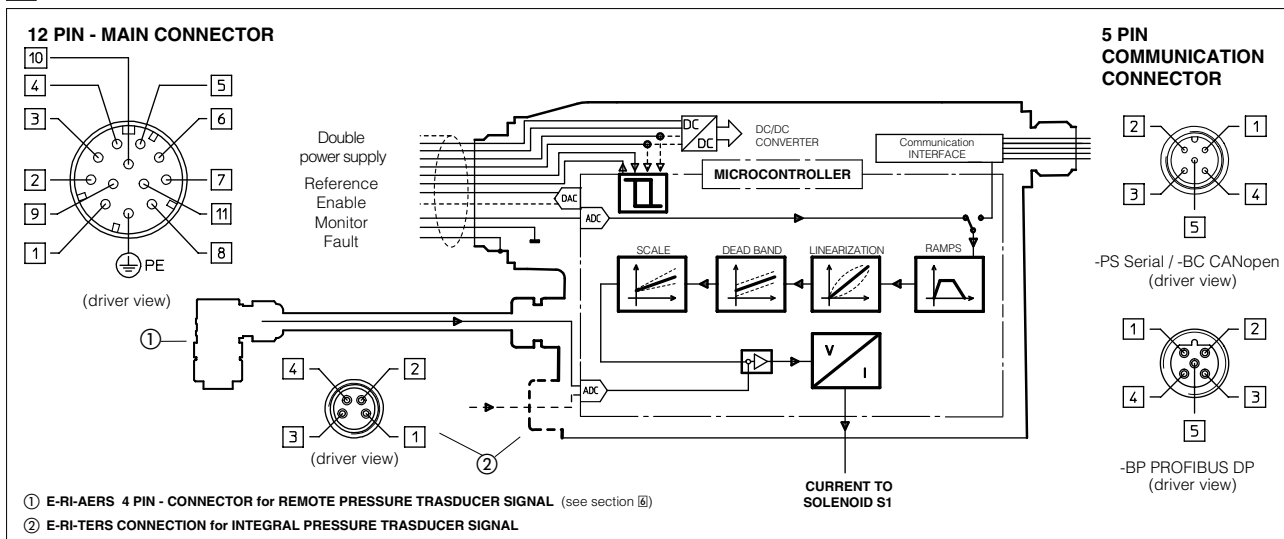

### 4 ELECTRONIC CONNECTIONS - 7 or 12 PIN MAIN CONNECTOR

Standard 7pin	/Z option 12pin	SIGNAL	TECHNICAL SPECIFICATIONS	NOTES
A	1	V+	Power supply 24 V <sub>dc</sub> for solenoid power stage (see 7.1)	Input - power supply
B	2	V0	Power supply 0 V <sub>dc</sub> for solenoid power stage (see 7.1)	Gnd - power supply
-	3	ENABLE	Enable (24 V <sub>dc</sub> ) or disable (0 V <sub>dc</sub> ) the driver (see 7.5)	Input - on/off signal
D	4	INPUT+	Reference analog input: ±10 V <sub>dc</sub> maximum range (4 ÷ 20 mA for /I option) - see 7.2 differential INPUT+ and INPUT- (for 7 pin standard execution) common mode INPUT+ referred to AGND (for 12 pin /Z option)	Input - analog signal
E	-	INPUT -		
C	5	AGND	Ground : signal zero for MONITOR signal ( pin F of 7 pin standard or pin 6 of /Z option) signal zero for INPUT+ signal ( pin 4 of /Z option)	Gnd - analog signal
F	6	MONITOR	Monitor analog output: ±10 V <sub>dc</sub> maximum range (4 ÷ 20 mA for /I option) - see 7.3	Output - analog signal
-	7	NC	do not connect	
-	8	NC	do not connect	
-	9	VL+	Power supply 24 V <sub>dc</sub> for driver's logic (see 7.4)	Input - power supply
-	10	VLO	Power supply 0 V <sub>dc</sub> for driver's logic (see 7.4)	Gnd - power supply
-	11	FAULT	Driver status : Fault (0V <sub>dc</sub> ) or normal working (24 V <sub>dc</sub> ) (see 7.6)	Output - on/off signal
G	PE	EARTH	Internally connected to driver housing	

**Note:** A minimum time of 270 to 590 ms have be considered between the driver energizing with the 24 V<sub>dc</sub> power supply and when the valve is ready to operate. During this time the current to the valve coils is switched to zero

### 5 ELECTRONIC CONNECTIONS - 5 PIN COMMUNICATION M12 CONNECTOR

PIN	-PS Serial		-BC CANopen		-BP PROFIBUS DP	
	SIGNAL	TECHNICAL SPECIFICATION	SIGNAL	TECHNICAL SPECIFICATION	SIGNAL	TECHNICAL SPECIFICATION
1	NC	do not connect	CAN_SHLD	Shield	+5V	for termination
2	NC	do not connect	NC	do not connect	LINE-A	Bus line (high)
3	RS_GND	Signal zero data line	CAN_GND	Signal zero data line	DGND	data line and termination Signal zero
4	RS_RX	Valves receiving data line	CAN_H	Bus line (high)	LINE-B	Bus line (low)
5	RS_TX	Valves transmitting data line	CAN_L	Bus line (low)	SHIELD	

### 6 ELECTRONIC CONNECTIONS - 4 PIN REMOTE PRESSURE TRASDUCER M8 CONNECTOR (only for AERS)

PIN	standard version		/C option (Ri = 316 Ω)	
1	TR	remote trasducer pressure signal (0 ÷ 10 V <sub>dc</sub> )	TR	remote trasducer pressure signal (4 ÷ 20 mA)
2	NC	reserved (do not connect)	NC	reserved (do not connect)
3	VT	remote trasducer power supply +24 V <sub>dc</sub>	VT	remote trasducer power supply +24 V <sub>dc</sub>
4	AGND	signal zero for power supply and signal	NC	reserved (do not connect)

See tab. G465 for the pressure transducer characteristics and connections.

### 7 SIGNALS SPECIFICATIONS

Atos proportional valves are CE marked according to the applicable directives (e.g. Immunity/Emission EMC Directive). Installation, wirings and start-up procedures must be performed according to the general prescriptions shown in table F003 and in the user manuals included in the E-SW programming software.  
The electrical signals of the valve (e.g. monitor signals) must not be directly used to activate safety functions, like to switch-ON/OFF the machine's safety components, as prescribed by the European standards (Safety requirements of fluid technology systems and components-hydraulics, EN-982)

#### 7.1 Power supply and wirings (pin A,B / pin 1,2)

The power supply must be appropriately stabilized or rectified and filtered: apply at least a 10000 µF/40 V capacitance to single phase rectifiers or a 4700 µF/40 V capacitance to three phase rectifiers.  
A safety fuse is required in series to each driver power supply: 2,5 A fuse

## 7.2 Reference Input Signal (pin D,E / pin 4,5)

The driver controls in closed loop the valve pressure proportionally to the external reference signal input.

The driver is designed to receive one analog reference input (pin D,E differential mode input).

The input range and polarity are software selectable within the  $\pm 10$  Vdc maximum range; default settings is  $0 \div 10$  Vdc .

Drivers with fieldbus interface (-BC or -BP) can be software set to receive reference value directly by the machine control unit (fieldbus master); in this case the analog reference input signal can be used for start-up and maintenance operations.

### Option /I

The maximum range of reference input signal is software selectable among  $4 \div 20$  mA (default with cable break detection),  $\pm 10$ mA,  $\pm 20$ mA or  $0 \div 20$ mA

### Option /Z

The reference input is available in common mode (pin 4 referred to pin 5) instead of the standard differential mode

## 7.3 Monitor Output Signal (pin F,C / pin 6,5)

The driver generates an analog output signal proportional to the actual pressure of the valve (pin F/6 referred to pin C/5); the monitor output signal can be software set to show other signals available in the driver (e.g. analog reference, fieldbus reference).

The output range and polarity are software selectable within  $\pm 10$  Vdc maximum range; default settings is  $0 \div 10$  Vdc .

### Option /I

The maximum range of monitor output signal is  $4 \div 20$  mA

## 7.4 Logic power supply (pin 9,10 - only for /Z option)

Option /Z provides separate power supply for the solenoid (pin 1,2) and for the digital electronic circuits (pin 9,10).

Cutting solenoid power supply allows to interrupt the valve functioning but keeping energized the digital electronics thus avoiding fault conditions of the machine fieldbus controller. This condition allows to realize safety systems in compliance with European Norms EN13849-1 (ex EN954-1).

Note: pin 2 and 10 (zero Volt) are connected together inside the electronics; see 7.1 for power supplies requirements

## 7.5 Enable Input Signal (pin 3,2 - only for /Z option)

To enable the driver, supply a 24 Vdc on pin 3 referred to pin 2: Enable input signal allows to enable/disable the current supply to the solenoid, without removing the electrical power supply to the driver; it is used to active the communication and the other driver functions when the valve must be disabled for safety reasons. This condition does not comply with European Norms EN13849-1 (ex EN954-1)

## 7.6 Fault Output Signal (pin 11,2 - only for /Z option)

Fault output signal indicates fault conditions of the driver (solenoid short circuits/not connected, reference signal cable broken for  $4 \div 20$ mA input, pressure transducer cable broken, etc.). Fault presence corresponds to 0 Vdc, normal working corresponds to 24 Vdc (pin 11 referred to pin2).

Fault status is not affected by the Enable input signal

## 7.7 Remote Pressure Transducer Signal (only for AERS - see section 8)

Remote pressure transducer with maximum  $0 \div 10$  Vdc output signal can be directly connected to the driver; refer to the valve's technical table to select the transducer's maximum pressure.

### Option /C

The maximum range of remote pressure transducer signal is software selectable among  $4 \div 20$  mA (default with cable break detection) or  $0 \div 20$  mA

## 7.8 Possible combined options: /CI, /CIZ, /CZ (only for AERS) and /IZ.

## 8 SOFTWARE TOOLS

The driver configuration and parameters can be easily set with the Atos E-SW programming software, available in three different versions according to the driver's communication interfacing: E-SW-PS (Serial), E-SW-BC (CANopen) and E-SW-BP (PROFIBUS DP).

A proper connection is required between the PC and the electronic driver communication port: for a more detailed description of software interface, PC requirements, adapters, cables and terminators, please refer to technical table G500.

Proportional valves with fieldbus communication interface (-BC and -BP) can be directly managed by the machine control unit; it is required to implement in the machine control the standard communication as described in the user manuals supplied with the relevant programming software.

### Programming software, must be ordered separately :

E-SW-\* (mandatory - first supply) = Dvd including E-SW-\* software installer and operator manuals; it allows the registration to Atos digital service

E-SW-\*-N (optional - next supplies) = as above but not allowing the registration to Atos digital service

On first supply of the E-SW-\* software, it is required to apply for the registration in the Atos download area : [www.download.atos.com](http://www.download.atos.com) .

Once the registration is completed, the password will be sent by email.

The software remains active for 10 days from the installation date and then it stops until the user inputs his password.

With the password you can also download, in your personal area, the latest releases of the Atos software, manuals, drivers and configuration files.

**USB Adapters, Cables and Terminators can be ordered separately (see tab. G500 )**

## 9 MAIN SOFTWARE PARAMETER SETTINGS

For a detailed descriptions of available settings, wirings and installation procedures, please refer to the programming manual E-MAN-RI-T(A)ERS included in the E-SW-\*\* Dvd programming software (see section 8).

### 9.1 Scale

Scale function allows to set the maximum valve pressure at maximum reference signal value.

This regulation allows to reduce the maximum valve regulation in front of maximum reference signal

### 9.2 Bias

Pressure proportional valves are limited in the minimum regulated pressure: the minimum pressure depends on the valve size, the regulated flow (only for relief valves) and the T port pressure.

Desired pressure requested through the reference signal (analog or fieldbus external input), must be greater than the minimum pressure to obtain the valve's best repeatability and response time.

The Bias function can be set to limit internally the minimum pressure reference independently from the external reference value thus optimizing valve's performances.

Refer to the programming manuals for a detailed description of other software selectable Bias functions

### 9.4 Ramps

The ramp generator allows to convert sudden change of electronic reference signal into smooth time-dependent increasing/decreasing of the valve opening.

Different ramp mode can be set:

- single ramp for any reference variation
- two ramps for increasing and for decreasing reference variations

Ramp generator is useful for application where smooth hydraulic actuation is necessary to avoid machine vibration and shocks.

If the proportional valve is driven by a closed loop controller, the ramps can lead to unstable behaviour, for these applications ramp function can be software disabled (default setting)

### 9.5 Linearization

Linearization function allows to set the relation between the reference input signal and the controlled valve's pressure.

Linearization is useful for applications where it is required to linearize the valve's regulation in a defined working condition

### 9.6 Dither

The dither is an high frequency modulation added to the valve's reference signal to reduce the hysteresis of the valve's regulation; in fact a small vibration in the valve's hydraulic regulation considerably reduces the mechanical friction effects (e.g. due to cylinder seals).

Dither frequency and amplitude are software selectable; the amplitude is automatically reduced at high reference values to avoid possible instability.

Lower frequency and higher amplitude reduce hysteresis but also reduce the regulation stability. In some application this can lead to vibration and noise: right setting usually depends on system setup. Dither default setting is disabled.

### 9.7 Transducer Scale (for AERS)

Transducer Scale function allows to adapt the driver to remote transducers with different output signal range and nominal pressure

### 9.1, 9.2 - Scale and Bias

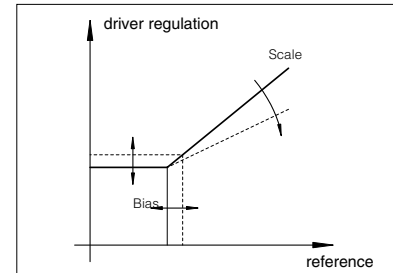

### 9.4 - Ramps

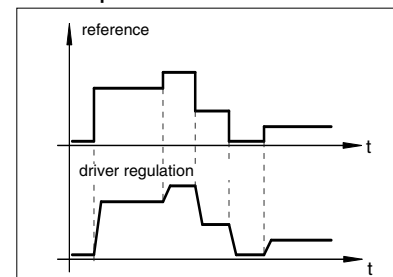

### 9.5 - Linearization

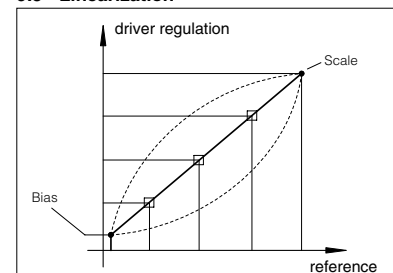

## 10 DRIVER CHARACTERISTICS

Power supply (see 7.1, 7.4)	Nominal: +24 V <sub>DC</sub> Rectified and filtered: V <sub>rms</sub> = 20 ÷ 32 V <sub>MAX</sub> (ripple max 10 % V <sub>PP</sub> )		
Max power consumption	50 W		
Reference input signal (see 7.2)	Voltage: range ±10 V <sub>DC</sub> Current: range 4 ÷ 20 mA	Input impedance: R <sub>i</sub> > 50 kΩ Input impedance: R <sub>i</sub> = 316 Ω	
Monitor output (see 7.3)	Output range :     voltage ±10 V <sub>DC</sub> @ max 5mA current 4 ÷ 20 mA @ max 500 Ω load resistance		
Enable input (see 7.5)	Range : 0 ÷ 5 V <sub>DC</sub> (OFF state), 9 ÷ 24 V <sub>DC</sub> (ON state), 5 ÷ 9 V <sub>DC</sub> (not accepted)    Input impedance: R <sub>i</sub> > 10 kΩ		
Fault output (see 7.6)	Output range :     0 ÷ 24 V <sub>DC</sub> ( ON state > [power supply] - 2 V ; OFF state < 1V ) @ max 50mA		
Alarms	Solenoid not connected/short circuit, cable break with current reference signal, overtemperature, under temperature, valve pressure trasducer cable break		
Format	Sealed box on the valve; IP67 protection degree		
Operating temperature	-20 ÷ 50 °C (storage -20 ÷ 70 °C)		
Mass	approx. 480 g		
Additional characteristics	Short circuit protection of solenoid's current supply; pressure control by P.I.D. with rapid solenoid switching		
Electromagnetic compatibility (EMC)	According to Directive 2004/108/CE (Immunity: EN 50082-2; Emission: EN 50081-2)		
Communication interface	-PS Serial	-BC CANopen - see tab. G510	-BP PROFIBUS - see tab. G510
Physical Layer Protocol	serial RS232 Atos ASCII coding	optical insulated CAN ISO11898 CANopen EN50325-4 + DS408	optical insulated RS485 PROFIBUS DP EN50170-2/IEC61158
Recommended wiring cable	LiYCY shielded cables:     0,5 mm <sup>2</sup> for length up to 40m [1,5 mm <sup>2</sup> for power supply and solenoid]		

## 11 MAIN CONNECTOR CHARACTERISTICS (to be ordered separately)

CODE	SP-ZH-7P	SP-ZM-7P	SP-ZH-12P
Type	Female straight circular socket plug 7pin	Female straight circular socket plug 7pin	Female straight circular socket plug 12pin
Standard	DIN 43563-BF6-3-PG11	According to MIL-C-5015 G	DIN 43651
Material	Plastic reinforced with fiber glass	Aluminium alloy with cadmiun plating	Plastic reinforced with fiber glass
Cable gland	PG11	PG11	PG16
Cable	LiYCY 7x 0,75 mm <sup>2</sup> max 20 m 7 x 1 mm <sup>2</sup> max 40 m	LiYCY 7x 0,75 mm <sup>2</sup> max 20 m 7 x 1 mm <sup>2</sup> max 40 m	LiCY 10 x 0,14 mm <sup>2</sup> (signal) LiYY 3 x 1 mm <sup>2</sup> (power supply)
Connection type	to solder	to solder	to crimp
Protection (DIN 40050)	IP 67	IP 67	IP 65

## 12 COMMUNICATION CONNECTOR CHARACTERISTICS (to be ordered separately)

CODE	-PS Serial Connector	-BC CANopen Connector	-BP PROFIBUS DP Connector
	SP-ZH-5P	SP-ZH-5P	SP-ZH-5P/BP
Type	Female straight circular socket plug 5 pin	Female straight circular socket plug 5 pin	Male straight circular socket plug 5 pin
Standard	M12 – IEC 60947-5-2	M12 – IEC 60947-5-2	M12 – IEC 60947-5-2
Material	Plastic	Plastic	Plastic
Cable gland	PG9	PG9	PG9
Cable	LiYCY 5x0,25 mm <sup>2</sup> shielded	CANBus Standard (301 DSP)	PROFIBUS DP Standard
Connection type	screw terminal	screw terminal	screw terminal
Protection (DIN 40050)	IP 67	IP 67	IP 67

## 13 REMOTE PRESSURE TRANSDUCER CONNECTOR CHARACTERISTICS (to be ordered separately)

CODE	SP-ZH-4P-M8/5
Type	Male straight circular socket plug 4 pin
Standard	M8 – IEC 60947-5-2
Material	Plastic
Cable gland	Connector moulded on cable 5 m lenght
Cable	4x 0,25 mm <sup>2</sup>
Connection type	cable
Protection (DIN 40050)	IP 67

## 14 OVERALL DIMENSIONS [mm]

