

Ex-proof pressure transducers type E-ATRA-7

analog, for open and closed loop systems - ATEX certification

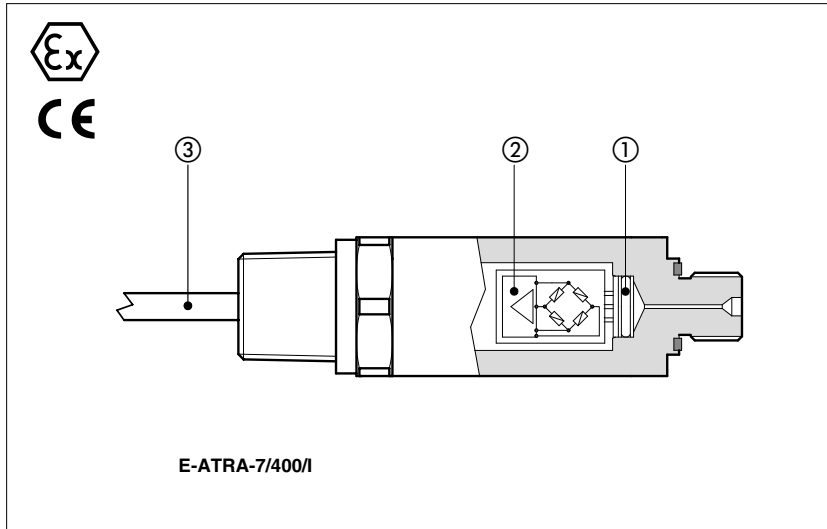

Ex-proof E-ATRA-7 pressure transducers measure the static and dynamic pressure of the hydraulic fluid, supplying a current output signal.

The sensor is composed by a thin-film circuit ①, with high resistance to overloads and pressure peaks.

The integrated electronic circuit ② supplies an amplified voltage or current output signal, proportional to the hydraulic pressure, with thermal drift compensation.

The transducer housing and electronics housing are designed to contain the possible explosion which could be caused by the presence of the gas mixture inside the housing, thus avoiding dangerous propagation in the external environment.

They are also designed to limit the external temperature according to the certified class to avoid the self ignition of the explosive mixture present in the environment.

E-ATRA-7 equip ex-proof pressure control digital proportional valves with integral transducer and electronics, TERS execution (see table F250).

They are also used in association with other Atos ex-proof digital proportionals to perform closed loop pressure controls:

- pressure control valves with remote pressure transducer, AERS execution (see table F250)

Features:

- Factory preset and calibrated
- 5 m cable connection ③
- IP67 protection degree
- Ex II 2 G Ex d II C T6 - ATEX 94/9/CE certification
- CE mark to EMC directive

1 MODEL CODE				
E-ATRA-7	/	400	/I	**
E-ATRA-7 = Pressure transducer amplified type for ex-proof applications				Series number
Pressure measuring range: 60 = 0 ÷ 60 bar 160 = 0 ÷ 160 bar 250 = 0 ÷ 250 bar 400 = 0 ÷ 400 bar				I = with current output signal 4 ÷ 20 mA

2 TRANSDUCER MAIN CHARACTERISTICS

Pressure measuring range	0 ÷ 60/160/250/400 bar; other values available on request note: negative pressure can damage the pressure transducer
Overload pressure	2 x full-scale
Burst pressure	4 x full-scale
Response time	≤ 1 ms
Operating temperature	-30 ÷ +100 °C (compensated 0 ÷ +80 °C / storage -30 ÷ +105 °C)
Thermal compensation	zero: ≤ ±0,02% FS/°C max; span: ≤ ±0,02% FS/°C max
Linearity and hysteresis range at 25°C	< ± 0.2 % FS
Materials	wetted parts: stainless steel and Elgiloy®; seals: FPM
Fluid Compatibility	hydraulic oil as per DIN51524..535 (for water-glycol, phosphate ester and skydrol® contact our tech.office)
Weight	approx. 200g
Electronic supply	24 Vdc nominal; maximum range 10 ÷ 30 Vdc
Output signal	4 ÷ 20 mA (2 wire)
Wiring protections	against reverse polarity on power supply and short-circuit on output signal
Electromagnetic compatibility (EMC)	According to Directive 2004/108/CE
Vibration resistance	20 g according to DIN EN 60068-2-6
Shock resistance	1000 g according to DIN EN 60068-2-27
Protection class	IP 67
Hydraulic connection	1/4" GAS - DIN 3852
Connection	Type: 5m cable 2 wires + shield
Ex protection	ATEX category 2G (operating instructions and safety relevant data in the EC-type examination certificate)
Ignition protection type	Ex d II C T6
Special features	available also with FM, CSA, GOST, INMETRO and KAZINMETR certification; please contact our technical office for further details.

3 INSTALLATION AND COMMISSIONING

3.1 Warning

E-ATRA-7 transducers have to be installed as near as possible to the point where the pressure must be measured, taking care that the oil flow is not turbulent.

3.2 Commissioning

Install the transducer in the hydraulic circuit.

Switch-off the power supply before connecting and disconnecting the transducer cable as shown in scheme 5

4 OVERALL DIMENSIONS [mm]

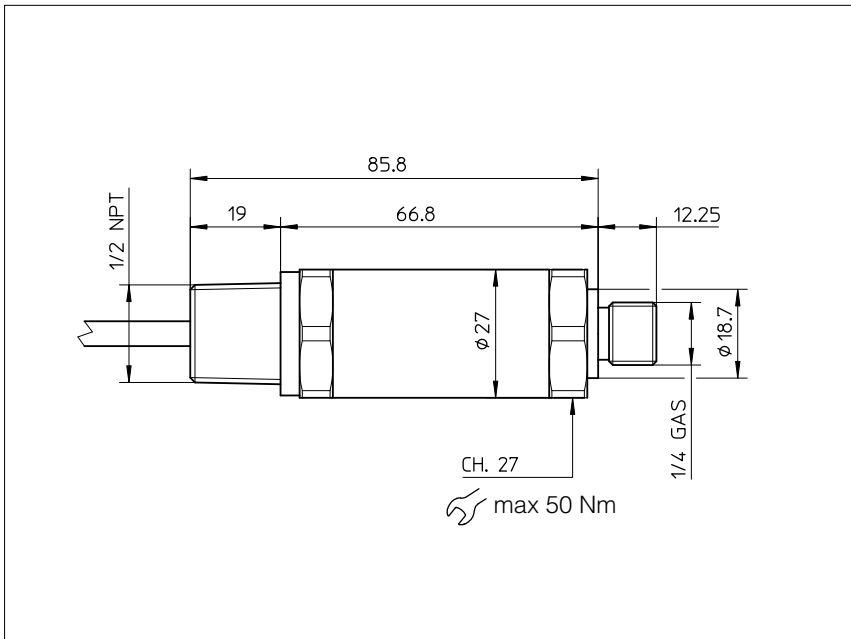

5 ELECTRONIC CONNECTIONS

