

Modular cartridge valves type LID

Check function, ISO 7368 sizes from 16 to 80

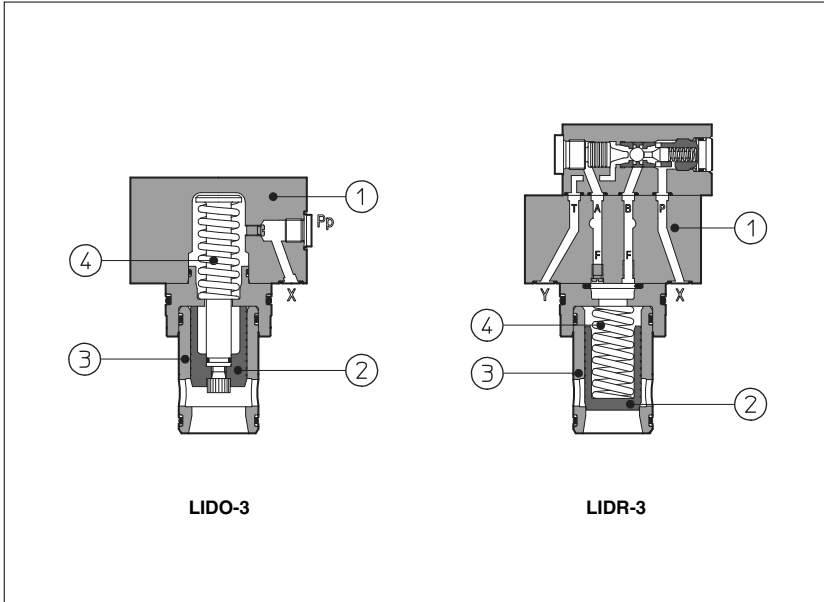

LID are cartridge valves for check function composed by a 2-way cartridge housed in a recess of standard dimensions and by a closing functional element ① called "cover".

The cartridge is composed by a poppet ② hydraulically piloted by means of internal connections in the cover (X, Z1, Z2, F, Y) and sliding into a drilled sleeve ③.

The flow is inhibited or permitted according to a proper pilot control.

Normally closed and normally open versions are available; cracking pressure value depends on poppet spring ④.

These valves are available in standard sizes 16 to 80 according to ISO 7368 (DIN 24342).

Flow up to 5600 l/min at $\Delta p = 6$ bar.
Pressure up to 350 bar.

1 MODEL CODE FOR COVERS

LI	D	A	-	1	/*	**	/*	*
Cover according to ISO 7368								Optional different provision or setting of the calibrated plugs in the pilot channels, see section 7
<p>D = direct operated valve</p> <p>A = normally closed; O = normally open; B = with shuttle valve for pilot selection; R = with hydraulically operated pilot check valve;</p> <p>Size: 1 = 16; 3 = 32; 5 = 50; 8 = 80 (only for LIDA) 2 = 25; 4 = 40; 6 = 63;</p> <p>LIDO is available only in sizes 16, 25, 32, 40, 50</p> <p>For model code of poppet, see section 4</p>								<p>Synthetic fluids: WG = water-glycol PE = phosphate ester</p> <p>Series number</p>
						Options: see section 7		

2 HYDRAULIC SYMBOLS

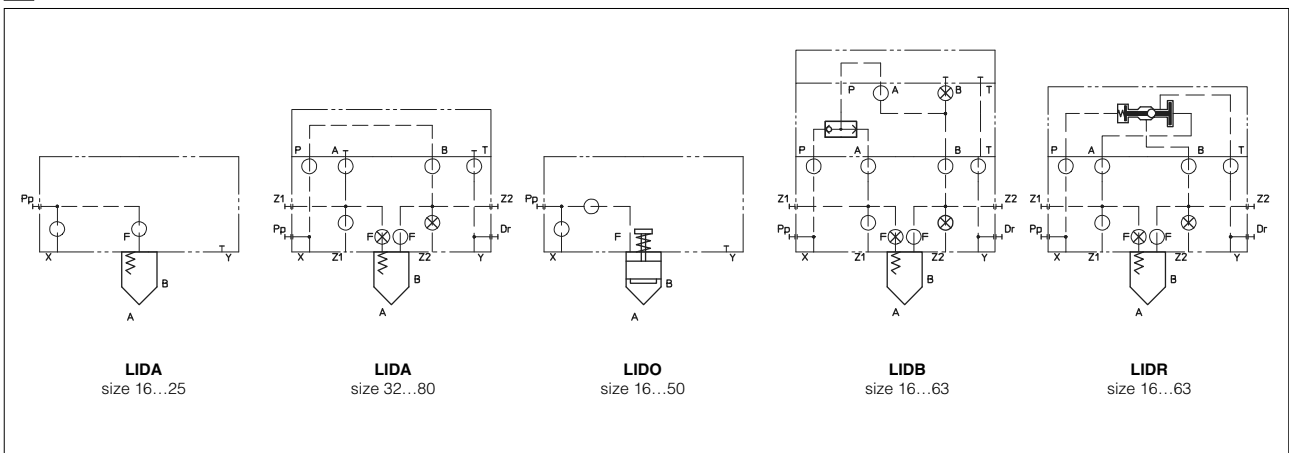

3 HYDRAULIC CHARACTERISTICS

Covers, see section 1	LIDA, LIDO, LIDB, LIDR																														
	32, 52 (1), 62, 63 (2)								33								42								43						
Poppet, see section 4, 5	16	25	32	40	50	63	80	16	25	32	40	50	63	80	16	25	32	40	50	63	80	16	25	32	40	50	63	80			
Size	16	25	32	40	50	63	80	16	25	32	40	50	63	80	16	25	32	40	50	63	80	16	25	32	40	50	63	80			
Max flow at $\Delta p = 6 \text{ bar}$ [l/min]	180	430	670	1400	2200	3500	5600	160	330	530	1100	1700	2600	4000	170	380	560	1300	2200	2800	4800	130	300	480	940	1500	2200	3500			
Max pressure [bar]	350 bar at port A, B, X, Z1, Z2; 70 bar at port Y																														

- (1) Poppet 52 is available only in sizes 16...50
 (2) Poppets 62, 63 are available only in sizes 16, 25, 32, 50

4 MODEL CODE FOR POPPETS, see section 5 for function

SC LI	-	16	32	1	**	/*
Cartridge according to ISO 7368						Synthetic fluids: WG = water-glycol PE = phosphate ester
Size, the same of relevant cover:		16 40 80 25 50 32 63			Series number	
Type of poppet, see section 3 for maximum flow:						
32, 33 (sizes 16...80)			= for all models except LIDO;			
42, 43 (sizes 16...80)			= as 32, 33 but with dumping nose. For all models except LIDO;			
52 (sizes 16...50)			= only for LIDA;			
62 (sizes 16, 25, 32, 40, 50)			= only for LIDO;			
63 (sizes 16, 25, 32, 50)			= as 62 but with dumping nose. Only for LIDO;			
Spring cracking pressure:						
1			= 0,3 bar for poppet 32, 42, 52;			
2			= 0,6 bar for poppet 33, 43;			
3			= 1,5 bar for poppet 32, 42, 52;			
6			= 3 bar for all poppets			
			= 5,5 bar for all poppets			

5 TYPICAL FUNCTIONS OF POPPETS

Code of poppet	32	33	42	43	52	62	63
Functional sketch (Hydraulic symbol)							
Typical section							
Area ratio (1)	1 : 1,1	1 : 2 for size 16, 25 1 : 1,6 for size 32 ÷ 80	1 : 1,1	1 : 2 for size 16, 25 1 : 1,6 for size 32 ÷ 80	1 : 1,1	1 : 1,1	1 : 1,1
Opening pressure A→B (2)	0,3 bar (spring 1) 1,5 bar (spring 2) 3 bar (spring 3) 6 bar (spring 6)	0,5 bar (spring 1) 2,5 bar (spring 3) 6 bar (spring 6)	0,4 bar (spring 1) 2,1 bar (spring 3) 4,3 bar (spring 6)	0,3 bar (spring 1) 1,3 bar (spring 2) 3,2 bar (spring 3) 6 bar (spring 6)	0,5 bar (spring 1) 2,7 bar (spring 3) 6 bar (spring 6)	0,4 bar (spring 1) 2,5 bar (spring 3) 4,9 bar (spring 6)	0,3 bar (spring 1) 1,5 bar (spring 2) 3 bar (spring 3) 6 bar (spring 6)
Opening pressure B→A (2)	3 bar (spring 1) 12,8 bar (spring 2) 32,5 bar (spring 3) 59,4 bar (spring 6)	0,5 bar (spring 1) 2,5 bar (spring 3) 6 bar (spring 6)	0,7 bar (spring 1) 3,7 bar (spring 3) 7,5 bar (spring 6)	3 bar (spring 1) 12,8 bar (spring 2) 32,5 bar (spring 3) 59,4 bar (spring 6)	0,5 bar (spring 1) 2,4 bar (spring 3) 6 bar (spring 6)	0,7 bar (spring 1) 3,7 bar (spring 3) 7,5 bar (spring 6)	- - - -

- (1) It is the ratio of the area on which the main pressure of the circuit is applied to the area on which the pilot pressure is applied
 (2) Depending on the spring cracking pressure and the area ratio of the poppet

6 MAIN CHARACTERISTICS OF MODULAR CHECK FUNCTION CARTRIDGE VALVES TYPE LID

Assembly position / location	Any position
Subplate surface finishing	Roughness index \sqrt{Ra} , flatness ratio 0,01/100 (ISO 1101)
Ambient temperature	-20 °C to + 70°C
Fluid	Hydraulic oil as per DIN 51524... 535; for other fluids see section 11
Recommended viscosity	15 ÷ 100 mm ² /s at 40°C (ISO VG 15÷100)
Fluid contamination class	ISO 19/16, achieved with in line filters at 25 µm and $\beta_{25} \geq 75$ (recommended)
Fluid temperature	-20°C +60°C (standard and /WG seals) -20°C +80°C (/PE seals)
Pilot ratio (only for LIDR)	Az1 : Ax = 3 : 1

7 OPTIONS

For LIDA and LIDO (sizes 16 and 25), LIDB (sizes 40 ÷ 63), LIDR (sizes 40 ÷ 63):

/E = with external attachments Pp and underneath port X supplied plugged;

For all the models:

/F = prearranged for coupling to an intermediate element with position detector for safety valves, see tab. E110.

******* = Calibrated plugs different from standard ones. All covers contain and are equipped with restrictors in the pilot channels according to the standard arrangement which is preset for each variant (see section 11). They can be exchanged with others for particular use. When ordering covers equipped with restrictors that are different from the standard ones it must be indicated at the end of the model code:

LIDB - 4 /E ** /WG

X

06

Channel where the restrictor have to be provided:
X = channel X **Z1** = channel Z1
F = channel F **Z2** = channel Z2

Size of the throttling hole in ten of millimeters:
05 = 0,5 mm **10** = 1 mm **17** = 1,7 mm
06 = 0,6 mm **12** = 1,2 mm **20** = 2 mm
08 = 0,8 mm **15** = 1,5 mm

8 DIAGRAMS OF POPPETS

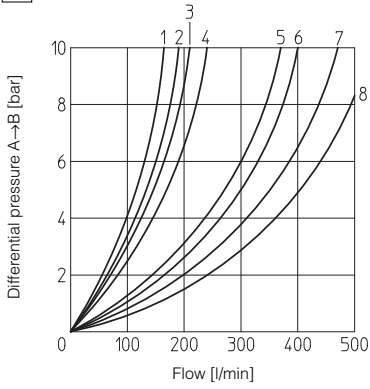

- 1 = SC LI-1643 5 = SC LI-2543
- 2 = SC LI-1633 6 = SC LI-2533
- 3 = SC LI-1642 7 = SC LI-2542
- 1632 -2532
- 4 = SC LI-1652 8 = SC LI-2552
- 1662 -2562
- 1663 -2563

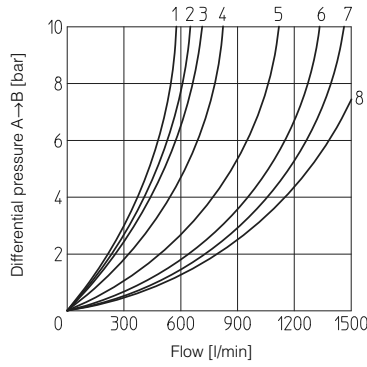

- 1 = SC LI-3243 5 = SC LI-4043
- 2 = SC LI-3233 6 = SC LI-4033
- 3 = SC LI-3242 7 = SC LI-4042
- 3232 -4032
- 4 = SC LI-3252 8 = SC LI-4032
- 3262 -4052
- 3263 -4062
- 3263 -4063

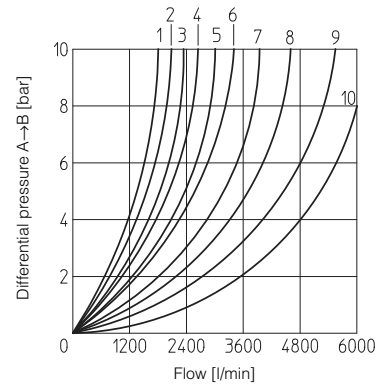

- 1 = SC LI-5043 5 = SC LI-6333
- 2 = SC LI-5033 6 = SC LI-6342
- 3 = SC LI-5042 7 = SC LI-6332
- 5032 -8043
- 4 = SC LI-5052 8 = SC LI-8033
- 5062 -5062
- 5063 -5063
- 6343 -6343
- 9 = SC LI-8042
- 10 = SC LI-8032

9 RECESS DIMENSIONS [mm]

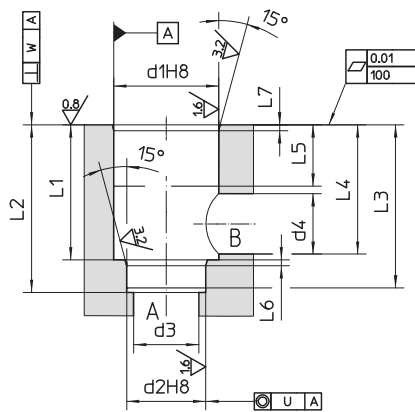

Sizes	Ø d1	Ø d2	Ø d3 max	Ø d4 max	L1	L2	L3	L4 max	L5	L6	L7	U	W
16	32	25	16	22,5	43 ^{+0,1} ₀	56 ^{+0,1} ₀	54	42,5	20	2	2	0,03	0,05
25	45	34	25	27	58 ^{+0,1} ₀	72 ^{+0,1} ₀	70	57	30	2,5	2,5	0,03	0,05
32	60	45	32	38,5	70 ^{+0,1} ₀	85 ^{+0,1} ₀	83	68,5	30	2,5	2,5	0,03	0,1
40	75	55	40	54,5	87 ^{+0,1} ₀	105 ^{+0,1} ₀	102	84,5	30	3	3	0,05	0,1
50	90	68	50	62,5	100 ^{+0,1} ₀	122 ^{+0,1} ₀	117	97,5	35	3	3	0,05	0,1
63	120	90	63	87	130 ^{+0,1} ₀	155 ^{+0,1} ₀	150	127	40	4	4	0,05	0,2
80	145	110	80	100	175 ^{+0,2} ₀	205 ^{+0,2} ₀	200	170,5	40	5	5	0,05	0,2

10 COVER INTERFACE DIMENSIONS [mm]

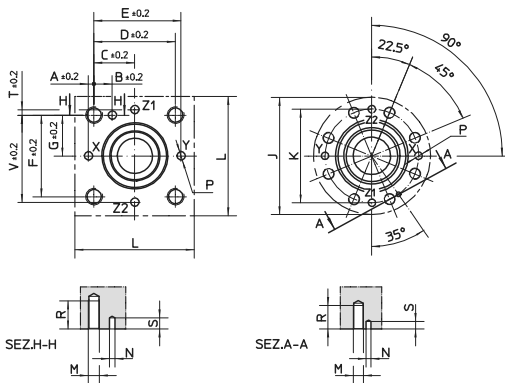

Sizes	A	B	C	D	E	F	G	J min	K	L min	M	ØN	ØP max	R	S max	T	V
16	2	12,5	23	46	48	46	23	-	-	65	M8	4	4	22	8	2	48
25	4	13	29	58	62	58	29	-	-	85	M12	6	6	30	8	4	62
32	6	18	35	70	76	70	35	-	-	102	M16	6	8	38	8	6	76
40	7,5	19,5	42,5	85	92,5	85	42,5	-	-	125	M20	6	10	46	8	7,5	92,5
50	8	20	50	100	108	100	50	-	-	140	M20	8	10	46	8	8	108
63	12,5	24,5	62,5	125	137,5	125	62,5	-	-	180	M30	8	12	66	8	12,5	137,5
80	-	-	-	-	-	-	-	250	200	-	M24	10	16	50	8	-	-

11 SCREWED ORIFICES IN STANDARD COVER EXECUTION: DIMENSIONS (1)

Port	Cover																	
	LIDA-1	LIDO-1	LIDB-1	LIDR-1	LIDA-2	LIDO-2	LIDB-2	LIDR-2										
X	-	M4 10A	-	-	-	M4 10A	-	-	M6 12A	-	-	-	-	M6 15F	-	-	-	-
P	-	-	-	M6 12A	-	-	-	M6 12A	-	-	-	M6 17A	-	-	M6 20A	-	-	M6 20A
Z2	-	-	-	M4 100F	-	-	-	M6 300F	-	-	-	M6 300F	-	-	M6 300F	-	-	M6 300F

(1) The showed codes define the orifice thread, diameter of the throttling hole in ten of millimeters and the form of throttle sectional area:
A = short calibrated hole **F** = long calibrated hole

12 COVER DIMENSIONS [mm]

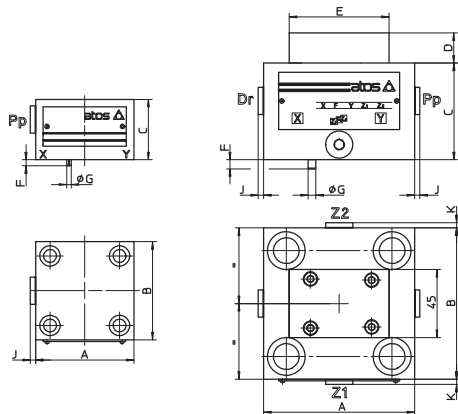

**LIDA (size 16 ÷ 25)
LIDO (size 16...50)**

LIDA (size 32...80)

Covers (1)	A	B	C	D	E	F	G	K	J	Port Pp-Dr	Port Z1-Z2	Seals	Fastening bolts (3)	Tightening torque [Nm]	Weight [Kg]
LIDA-1 LIDO-1	65	65	40	-	-	4	3	-	3,5	G 1/4	-	2 OR 108 1 OR 108 (2)	Nr. 4 M8x45	35	1,4
LIDA-2 LIDO-2	85	85	40	-	-	6	5	-	3,5	G 1/4	-	2 OR 108 1 OR 108 (2)	Nr. 4 M12x45 (4)	125	1,8
LIDA-3 LIDO-3	100	100	50 60 (2)	20	66	6	5	-	3,5	G 1/4	-	4 OR 2043 1 OR 2043 (2)	Nr. 4 M16x55 (5)	300	2,3
LIDA-4 LIDO-4	125	125	60 100	20	66	6	5	-	3,5 3	G 1/4	-	4 OR 2050 1 OR 2050	Nr. 4 M20x70 (6)	600	6,2
LIDA-5 LIDO-5	140	140	70 110 (2)	20	66	4	6	3,5	3,5	G 1/4	G 1/4	4 OR 2050 1 OR 2050 (2)	Nr. 4 M20x80 (7)	600	9,3
LIDA-6	180	180	80	20	66	4	6	3,5	3,5	G 3/8	G 3/8	4 OR 2056	Nr. 4 M30x90	2100	17,1
LIDA-8	∅ 250	-	80	30	73	6	8	-	3,5	G 3/8	-	4 OR 123	Nr. 8 M24x90	1000	27

- (1) For LIDO-2: the external attachment Pp is located at Y port side of the cover;
 (2) Only for LIDO;
 (3) Hexagon socket head screw according to DIN 912 class 12.9
 (4) M12x50 for LIDO-2;
 (5) M16x60 for LIDO-3;
 (6) M20x100 for LIDO-4;
 (7) M20x110 for LIDO-5;

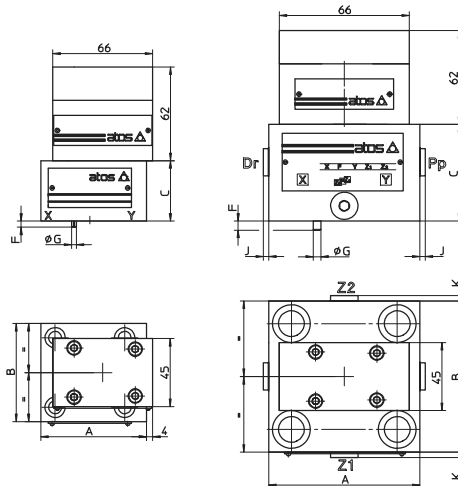

LIDB (size 16)

LIDB (size 25...63)

Covers	A	B	C	F	G	J	K	Port Pp-Dr	Port Z1-Z2	Seals	Fastening bolts (2)	Tightening torque [Nm]	Weight [Kg]
LIDB-1	70	65	40	4	3	-	-	-	-	4 OR 108	Nr. 4 M8x45	35	2,2
LIDB-2	85	85	40	6	5	-	-	-	-	4 OR 108	Nr. 4 M12x45	125	2,6
LIDB-3	100	100	50	6	5	-	-	-	-	4 OR 2043	Nr. 4 M16x55	300	3,1
LIDB-4	125	125	60	6	5	3,5	-	G 1/4	-	4 OR 2050	Nr. 4 M20x70	600	7
LIDB-5	140	140	70	4	6	3,5	3,5	G 1/4	G 1/4	4 OR 2050	Nr. 4 M20x80	600	10,1
LIDB-6 (1)	180	180	80	4	6	3,5	3,5	G 3/8	G 3/8	4 OR 2056	Nr. 4 M30x90	2100	17,9

- (1) The position of external attachments Pp, Dr, Z1 and Z2 are inverted each others respect to the showed sketch
 (2) Hexagon socket head screw according to DIN 912 class 12.9

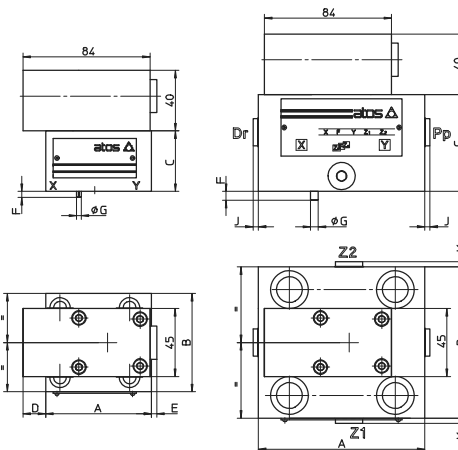

LIDR (size 16...32)

LIDR (size 40...63)

Covers	A	B	C	D	E	F	G	J	K	Port Pp-Dr	Port Z1-Z2	Seals	Fastening bolts (2)	Tightening torque [Nm]	Weight [Kg]
LIDR-1	70	65	40	4	3,5	4	3	-	-	-	-	4 OR 108	Nr. 4 M8x45	35	2,5
LIDR-2	85	85	40	13,5	-	6	5	-	-	-	-	4 OR 108	Nr. 4 M12x45	125	2,9
LIDR-3	100	100	50	6	-	6	5	-	-	-	-	4 OR 2043	Nr. 4 M16x55	300	3,4
LIDR-4	125	125	60	-	-	6	5	3,5	-	G 1/4	-	4 OR 2050	Nr. 4 M20x70	600	7,3
LIDR-5	140	140	70	-	-	4	6	3,5	3,5	G 1/4	G 1/4	4 OR 2050	Nr. 4 M20x80	600	10,4
LIDR-6 (1)	180	180	80	-	-	4	6	3,5	3,5	G 3/8	G 3/8	4 OR 2056	Nr. 4 M30x90	2100	18,3

- (1) The position of external attachments Pp, Dr, Z1 and Z2 are inverted each others respect to the showed sketch
 (2) Hexagon socket head screw according to DIN 912 class 12.9