

Standard solution for torque bar press brakes

CE and non CE design

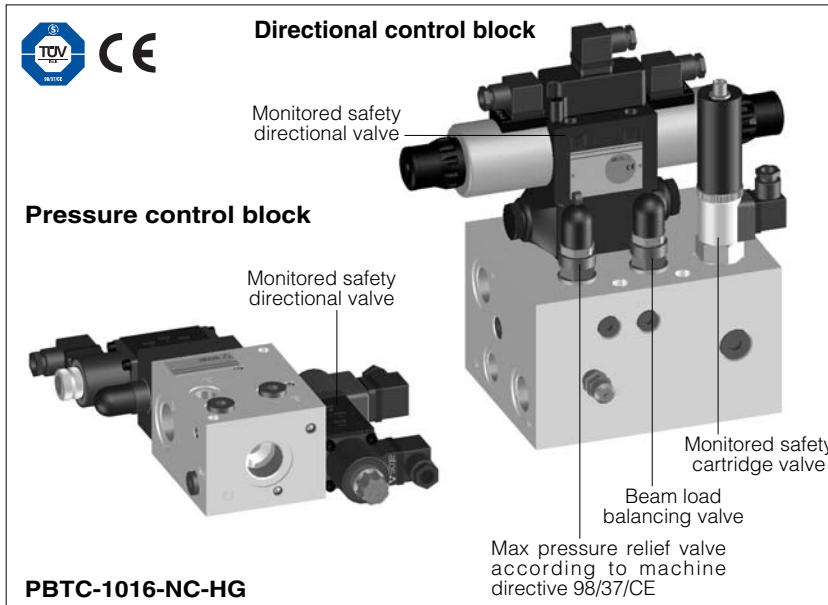

New standard electrohydraulic solution for torque bar press brakes are available in CE (PBTC) or non CE (PBT) design. PBTC design is CE certified by TÜV according to the EN 12622.

They are composed by:

- Size 16 pressure control block
- Size 10 directional control block

Two different executions can be selected depending on the choice of the prefilling function.

PBT(C)-1016-NO

To be coupled with n°2 prefilling blocks with ISO/DIN normally open cartridges, see section 2.

PBT-1016-NC

To be coupled with n°2 prefilling valves mushroom type (not supplied by Atos) to be integrated into the cylinder heads.

The NC solution is available with optional pressure reducing valve (option /G) to limit the pilot pressure to the normally closed prefilling valves.

Safety notes for installation and start-up of the CE blocks are supplied on a separate document enclosed in the shipment envelope.

1 MODEL CODE OF CONTROL BLOCKS SOLUTION

PBT	C	-	10	16	-	NC	/G
Conventional press brakes solution							Optional control block reducing valve, only for -NC
Certified design - = non CE C = CE certified (only for NO version)						NO = for normally open Atos PFB prefilling blocks NC = for normally closed prefilling blocks not available in Atos range	
Directional control valve size 10 = size 10						Pressure control block size 16 = size 16	

2 MODEL CODE OF PREFILLING BLOCKS

PFB	-	40
Prefilling block to be coupled with -NO control block type		Prefilling size 25, 32, 40, 50

3 TECHNICAL CHARACTERISTICS of PBTC solution and PFB prefilling blocks

Pressing Force (kN)	Pump flow (l/min)	Working pressure (bar)	PFB prefilling valve size	PFB nominal flow in suction condition (l/min)
400 - 5000	Up to 90	Up to 315	25	150
			32	225
			40	350
			50	500

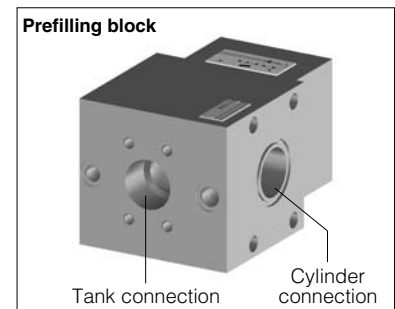

Note: The above data are indicative. The selection of the solutions must be checked with Atos technical dept according to the press characteristics

4 MAIN CHARACTERISTICS

Ambient temperature	-20°C to +70°C
Fluid	Hydraulic oil as per DIN 51524 535
Recommended viscosity	15 ÷ 100 mm ² /s at 40°C (ISO VG 15 ÷ 100)
Fluid contamination class	ISO 18/15, achieved with in line filters at 10 µm value to β ₁₀ ≥ 75 (recommended)
Fluid temperature	-20°C +60°C

5 BLOCKS ASSEMBLING -Typical machine configuration

<p>Composition of PBT(C)-1016-*</p> <p>N°1 size 16 pressure control block ② N°1 directional control block with size 10 directional solenoid valve ①</p>	
<p>Prefilling blocks model code</p> <p>N°2 PFB-25, 32, 40, 50 to be used with solution PBT(C)-1016-NO ③</p> <p>Normally closed prefilling valves (not Atos) to be used with solution PBT-1016-NC</p>	
<p>Max downstroke speed limiter</p> <p>To limit the max downstroke speed, a flow control valve type AQFR-25 (see section 6, valve pos. 17) can be optionally connected between the directional control block and the cylinders rod sides</p>	

6 HYDRAULIC SCHEME (PBTC-1016-NO CE solution)

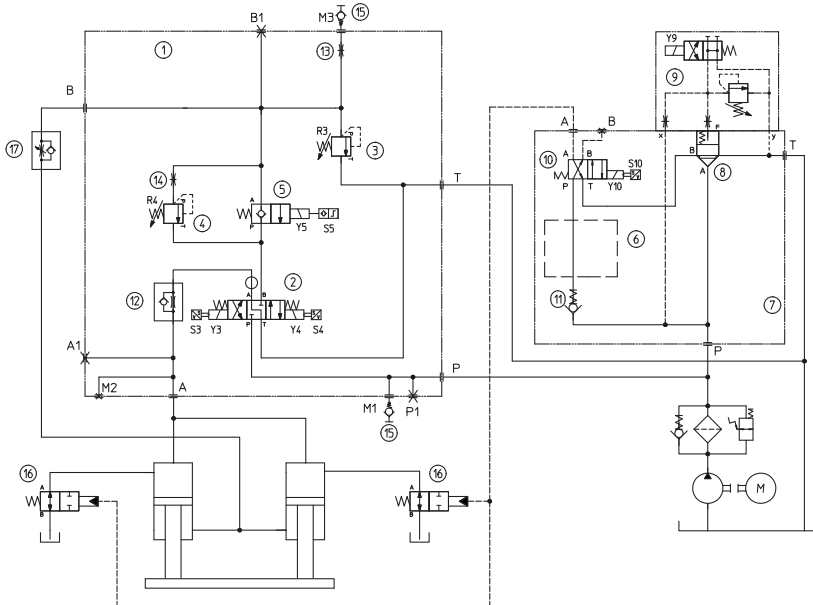

Pos	Description	Atos code	PBT	PBTC
1	SUBPLATE		●	●
2	MONITORED SAFETY DIRECTIONAL VALVE	DKE-1716/FI/NC-X		●
2	DIRECTIONAL VALVE	DKE-1716-X	●	
3	SAFETY PRESSURE RELIEF VALVE	CART M6/350/RS	●	●
4	BALANCING VALVE	CART M6/350/R	●	●
5	MONITORED SAFETY VALVE	JO-DL-10-2/NC/FI-X		●
5	CARTRIDGE	JO-DL-10-2/NC-X	●	
6	REDUCING VALVE	HG-031/210	Δ	
7	SUBPLATE		●	●
8	CARTRIDGE	SC LI-16313	●	●
9	CONTROL PRESSURE VALVE	LIMHA-1/350	●	●
10	MONITORED SAFETY DIRECTIONAL VALVE	DHU-0631/2/AFIE-X		●
10	DIRECTIONAL VALVE	DHU-0631/2/A-X	●	
11	CHECK VALVE	CART ADR-10	●	●
12	DECOMPRESSION BLOCK	080279 KR-003	●	●
13	RESTRICTOR		●	●
14	RESTRICTOR		●	●
15	MINIMESS	Y-AK-04-GOR	●	●
16	PREFILLING VALVE	ATOS PFB BLOCK or CUSTOMER N.C. VALVES	○	○
17	FLOW CONTROL VALVE	AQFR-25	○	○

The above scheme refers to PBTC-1016-NO execution coupled with Atos normally open prefilling valves, pos. ⑯

For system with normally closed prefilling valves type () in pos. ⑯

The prefilling valves pilot line must be connected to port B of the solenoid valve in pos. ⑩, port A is plugged

Note: not CE version have the same hydraulic scheme but without monitor signal for valves ② ⑤ ⑩

Δ : optional pressure reducing valve only for normally closed prefilling blocks

○ : to be ordered separately

7 INSTALLATION DIMENSION OF DIRECTIONAL AND PRESSURE CONTROL BLOCK

DIRECTIONAL CONTROL BLOCK

Dotted line = monitored version for CE block

Fastening bolts:
4 socket head screw M8x140 class 12.9

Port dimensions:

P / P1 = G 1"

T = G 1 1/4"

A / A1 = G 3/4"

B / B1 = G 1"

M* = G 1/4"

Hydraulic scheme

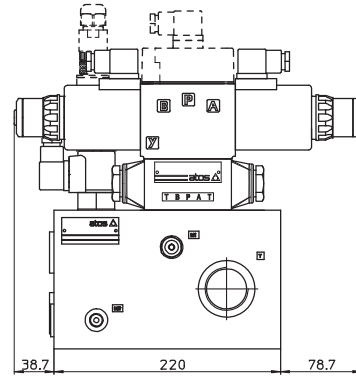
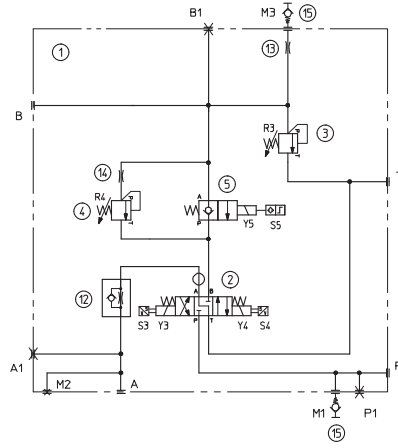

SP-ZH-4P/68

Sensor plastic connector,
to be ordered separately

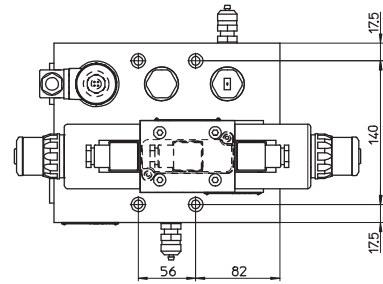
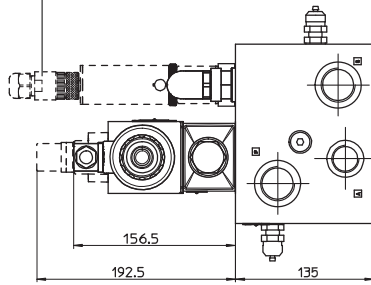

PRESSURE CONTROL BLOCK

Dotted line = monitored version for CE block

Fastening bolts:
2 socket head screw M8x95 class 12.9

Port dimensions:

P = G 1"

T = G 1"

A = G 3/8"

B = G 3/8"

M2 = G 1/4"

Hydraulic scheme

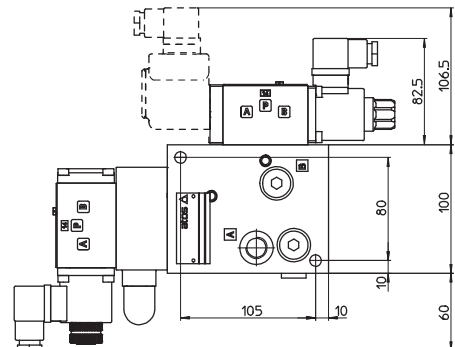
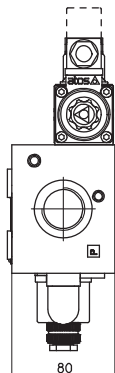
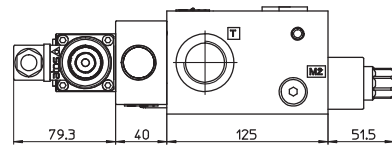
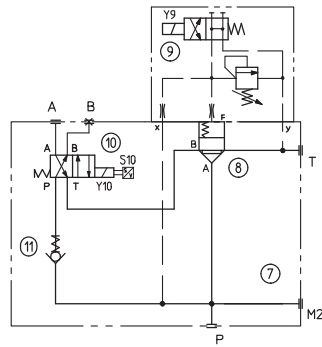

INSTALLATION DIMENSION OF PRESSURE CONTROL BLOCK with option /G

PRESSURE CONTROL BLOCK with option /G (only NC solution)

Fastening bolts:
2 socket head screw M8x95 class 12.9

Port dimensions:
P = G 1"
T = G 1"
A = G 3/8"
B = G 3/8"
M2 = G 1/4"

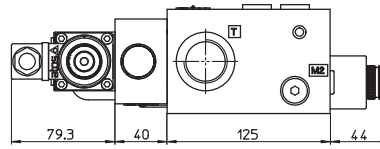

Hydraulic scheme

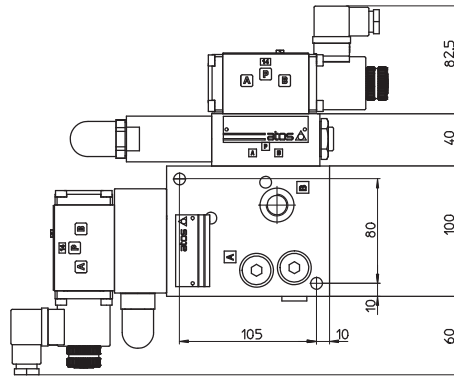
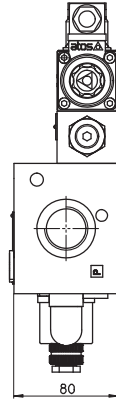
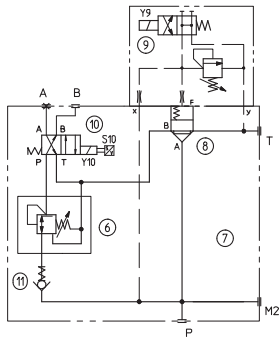

8 INSTALLATION DIMENSIONS OF PREFILLING BLOCKS TYPE PFB

PFB-25

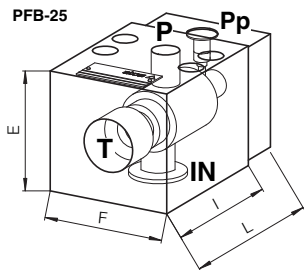

**PFB-32
PFB-40**

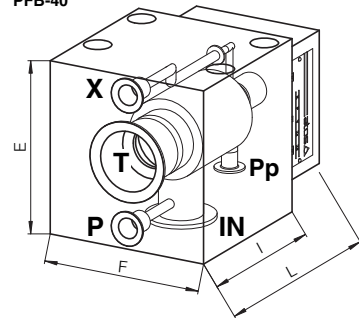

Model code	Size	Dimensions							Bolts	Seal	Port			
		A	B	D	E	F	I	L			T	X	P	Pp
PFB-25	25	70	28	∅24	90	95	115	155	M10X90	OR 4137	G1"1/4	-	G3/8"	G1/4"
PFB-32	32	100	62	∅32	130	125	185	125	M12X125	OR 149	G1"1/2	G3/8"	G3/8"	G1/4"
PFB-40	40	78	122	∅50	165	150	250	150	M16X170	OR 4237	2"SAE 3000	G3/8"	G1/2"	G1/4"

Cylinder surface

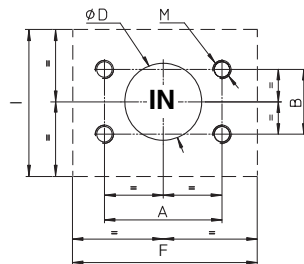

PFB-25

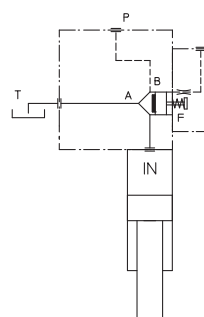

**PFB-32
PFB-40**

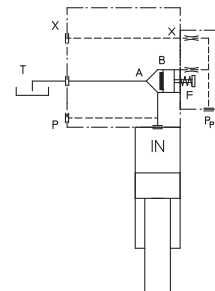

Model code	Size	Dimensions							Bolts	Seal	Port		
		D	E	F	I	L	N	P			T	X	Pp
PFB-50	50	∅50	160	180	160	270	17.5	270	M16X150	OR 4237	2"1/2 SAE 3000	G3/8"	G1/4"

PFB-50

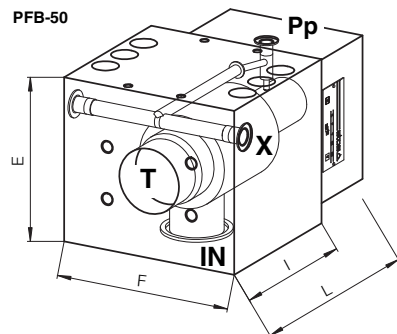

Cylinder surface

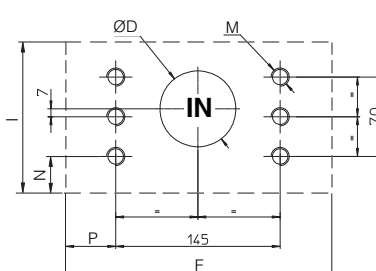

PFB-50

