

Hand pumps type PM

2-plunger

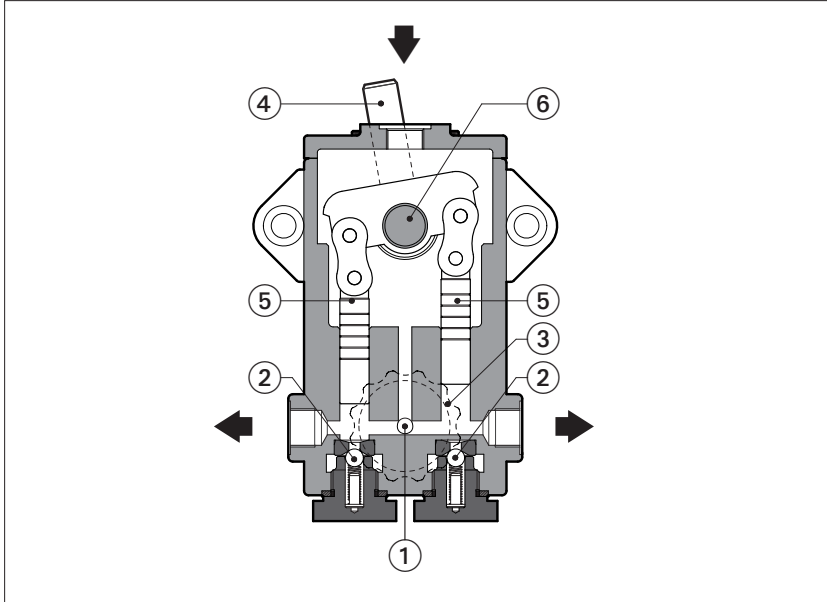

PM are double alternate-acting hand pumps with simple and rugged construction for minimum service and long operating life.

They are provided with one by-pass valve ① which connects directly the delivery ports with the inlet port through the delivery valves ②. The by-pass valve is operated by a handwheel ③.

Pumping operation is made by alternative movement of the lever ④ and consequently movement of plungers ⑤, after having locked the by-pass valve by means of the handwheel.

The splined shaft attachment ⑥ permits to turn the lever shaft in the best position.

On the pump body are available two outlet ports (one supplied plugged).

Displacements **from 12 to 20 cm³**
for double stroke.

Max pressure **250 bar**

1 MODEL CODE

PM	-	112	*	/	*
2-plunger hand pump			Seals material: omit for NBR (mineral oil & water glycol) PE = FPM		
Displacement, see section 2			Series number		
112 = 12 cm ³ /double stroke					
120 = 20 cm ³ /double stroke					

2 OPERATING CHARACTERISTICS with hydraulic fluid having a viscosity of 24 mm²/s and 40°C

Model	Displacement for double stroke [cm ³]	Max pressure [bar]	Shaft rotation angle [degree]	Maximum torque required [Nm]
PM-112	12	250	± 35°	133
PM-120	20	120	± 35°	116

3 MAIN CHARACTERISTICS OF HAND PUMP TYPE PM

Installation position	Vertical position, with inlet port facing upward to ensure complete case filling		
Commissioning	<p>Pumping operation is made by alternative movement of the lever after closing by-pass valve.</p> <p>Note: the by-pass valve connects the delivery ports with inlet port and when locked it could allow some leakage from outlet ports.</p> <p>Two opposite outlet ports are available for pump delivery: one of these is supplied plugged.</p> <p>The pumps are supplied without lever harm that could made by a simple tube with \varnothing 18 mm inside diameter. Usually a length of 500 to 600 mm is appropriate.</p> <p>Lever position can be selected by proper assembling of lever on splined shaft.</p>		
Ambient temperature	Standard = $-25^{\circ}\text{C} \div +80^{\circ}\text{C}$ / PE option $-15^{\circ}\text{C} \div +80^{\circ}\text{C}$		
Fluid	Hydraulic oil as per DIN 51524...535; for other fluids see section I		
Recommended viscosity	10 \div 100 mm ² /sec at 40°C (ISO VG 15 - 100)		
Max fluid contamination level	normal operation	ISO4406 class 21/19/16 NAS1638 class 10	see also filter section at www.atos.com or KTF catalog
	longer life	ISO4406 class 18/16/13 NAS1638 class 8	
Fluid temperature	$-20^{\circ}\text{C} +60^{\circ}\text{C}$	$-20^{\circ}\text{C} +50^{\circ}\text{C}$ (water glycol)	$-20^{\circ}\text{C} +80^{\circ}\text{C}$ (/PE seals)
Compliance	RoHS Directive 2011/65/EU as last update by 2015/863/EU REACH Regulation (EC) n°1907/2006		

4 DIMENSIONS [mm]

