

Ex-proof axial piston pumps type PVPCA

for potentially explosive atmospheres - ATEX, EAC

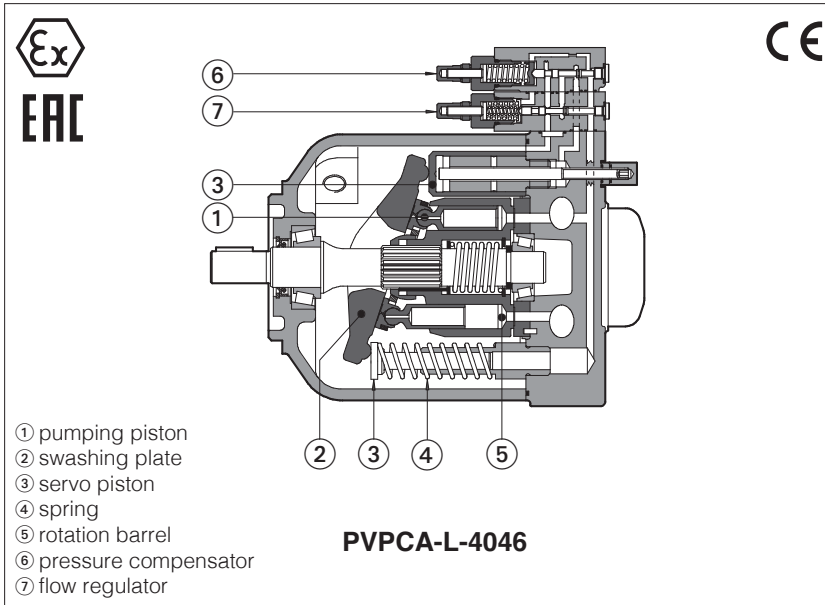

PVPCA are variable displacement axial piston pumps for high pressure operation, and low noise level, available in a wide range of hydraulic and proportional controls.

They are certified for application in potentially explosive atmospheres according to ATEX, EAC protection mode Ex II 2/2G Ex h IIC T5, T4 Gb, and Ex II 2/2D Ex h IIC T100°C, T135°C Db (group II for surface plants with gas, vapours and dust environment, category 2, zone 1, 2, 21 and 22).

The external surface temperature of the pump is in accordance with the certified class, to avoid the self ignition of the explosive mixture present in the environment.

Displacement: **29-46-73-88 cm³/rev.**
 Pressure: **280 bar working**
350 bar peak

1 MODEL CODE

PVPCA	XA	-	C	-	4	046	/	31044	/	1	D	-	GK	/	7	24DC	*	/	*	
Variable displacement vane pump with ex-proof certification																				
Additional suffix for pumps with through shaft, for coupling with 2nd pump type PFEA:																				
XA =for coupling with PFEA-3* (only for PVPCA*-3*)																				
XB =for coupling with PFEA-4* (only for PVPCA*-4*)																				
XC =for coupling with PFEA-5* (only for PVPCA*-5*)																				
Type of control (1):																				
C = manual pressure compensator																				
CH = manual pressure compensator with venting																				
R = remote pressure compensator																				
L = load sensing (pressure & flow)																				
LW = constant power (combined pressure & flow)																				
For proportional controls see note (2)																				
Size:																				
3 = for displacement 029																				
4 = for displacement 046																				
5 = for displacement 073 and 090																				
Max displacement of axial piston pump:																				
029 = 29 cm ³ /rev																				
046 = 46 cm ³ /rev																				
073 = 73 cm ³ /rev																				
090 = 88 cm ³ /rev																				
Type of PVPCA (for double pumps), see tech table A160																				
			Seals material: omit for NBR (mineral oil & water glycol) PE = FKM (3)																	
			Series number																	
			Voltage code , only for CH: see tech table EX010																	
			Option: 7 = for ambient temperature up to 70°C (3) Only for CH control: O = horizontal cable entrance WP = prolonged manual override protected by metallic cap																	
			Solenoid threaded connection (only for CH control): GK = GK-1/2" ISO/UNI-6125 (tapered) NPT = 1/2" NPT ANSI B2.1 (tapered) M = M20x1,5 UNI-4535																	
			Direction of rotation (viewed at the shaft end): D = clockwise S = counterclockwise																	
			Shaft (SAE Standard): 1 = keyed (7/8" for 029 - 1" for 046 - 1 1/4" for 073 and 090) 5 = splined (13 teeth for 029 - 15 for 046 - 14 for 073 and 090)																	

(1) Pumps CH, CZ, LQZ, PES and PERS are supplied with two certificates, one for the pump, and one for control valve

(2) Pumps with proportional controls type: CZ, LQZ, PES and PERS are available on request.
 For the technical characteristics of PVPCA pumps with proportional controls, see tech table AS170

(3) Pumps with option /7 are always equipped with seals FKM

2 GENERAL CHARACTERISTICS

Assembly position	Any position. The drain port must be on the top of the pump. Drain line must be separated and unrestricted to the reservoir and extended below the oil level as far from the inlet as possible. Suggested maximum line length is 3 m.
Ambient temperature range	-20°C to +70°C
Compliance	Explosion proof protection "Ex h", see section 6 RoHs Directive 2011/65/EU as last update by 2015/863/EU (only PVPCA-CH) REACH Regulation (EC) n°1907/2006

3 OPERATING CHARACTERISTICS

Pump model	PVPCA*-3029	PVPCA*-4046	PVPCA*-5073	PVPCA*-5090
Displacement [cm ³ /rev]	29	46	73	88
Theoretical max flow at 1450 rpm [l/min]	42	66.7	105.8	127.6
Max working pressure (1) [bar]	280	280	280	250
Peak pressure [bar]	350	350	350	315
Min/Max inlet pressure [bar abs.]	0,8/25	0,8/25	0,8/25	0,8/25
Max pressure on drain port [bar abs.]	1.5	1.5	1.5	1.5
Power consumption at 1450 rpm, at max pressure and displacement [kW]	19.9	31.6	50.1	54.1
Max torque on the first shaft [Nm]	shaft type 1: 200 shaft type 5: 190	shaft type 1: 230 shaft type 5: 330	shaft type 1: 490 shaft type 5: 620	shaft type 1: 490 shaft type 5: 620
Max permissible load on drive shaft (3) [N]	F ax	1000	1500	2000
	F rad	1500	1500	3000
Speed rating (2) [rpm]	600-3000	600-2600	600-2200	600-1850

Notes: For speeds over 1800 rpm the inlet port must be under oil level with adequate pipes.

(1) Maximum pressure for all models with water glycol fluid is **160 bar**, with option /PE is **190 bar**.

(2) Max speed with options /PE and for water glycol fluid is **2000/1900/1600/1500 rpm** respectively for the four sizes.

(3) See scheme below

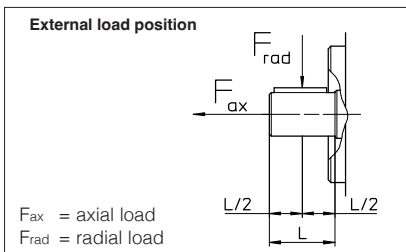

4 ELECTRICAL CHARACTERISTICS FOR VERSION CH

Valve type	DHA
Voltage code (1)	VDC ±10% 12DC, 24DC, 28DC, 48DC, 110DC, 125DC, 220DC
	VAC 50/60 Hz ±10% 12AC, 24AC, 110AC, 230AC
Power consumption at 20°C	8W
Coil insulation	class H
Protection degree with relevant cable gland	IP66/67 to DIN EN60529
Duty factor	100%

(1) For alternating current supply a rectifier bridge is provided built-in the solenoid

For power supply frequency 60 Hz, the nominal supply voltage of solenoids 110AC and 230AC must be 115/60 and 240/60 respectively

5 SEALS AND HYDRAULIC FLUIDS - for other fluids not included in below table, consult our technical office

Seals, recommended fluid temperature	NBR seals (standard) = -20°C ÷ +60°C, with HFC hydraulic fluids = -20°C ÷ +50°C FKM seals (/PE option) = -20°C ÷ +80°C		
Recommended viscosity	15÷100 mm ² /s - max start-up viscosity = 1000 mm ² /s		
Max fluid contamination level	normal operation	ISO4406 class 20/18/13 NAS1638 class 9	see also filter section at www.atos.com or KTF catalog
	longer life	ISO4406 class 18/16/11 NAS1638 class 7	
Hydraulic fluid	Suitable seals type	Classification	Ref. Standard
Mineral oils	NBR, FKM	HL, HLP, HLPD, HVLP, HVLPD	DIN 51524
Flame resistant without water	FKM	HFDU, HFDR (1)	ISO 12922
Flame resistant with water	NBR	HFC (1)	

(1) See section **6**

6 PERFORMANCE RESTRICTIONS WITH FLAME RESISTANT FLUIDS

6.1 HFDU and HFDR - Phosphate ester

PVPC size	3029	4046	5073	5090
Max pressure working / peak (bar)	200 / 240			
Max speed (1) (rpm @ VMAX)	2050	1850	1700	1550
Ambient temperature range (°C)	-10 ÷ +70			
Bearing life (% of bearing life with mineral oil) (%)	90			

(1) With an inlet pressure of 1 bar abs

6.2 HFC - Water-glycol (35 ÷ 55% of water)

PVPC size	3029	4046	5073	5090
Max pressure working / peak (bar)	180 / 210			
Max speed (1) (rpm @ VMAX)	2050	1850	1700	1550
Ambient temperature range (°C)	-10 ÷ +60			
Bearing life (% of bearing life with mineral oil) (%)	40			

(1) With an inlet pressure of 1 bar abs

7 CERTIFICATION DATA





Certification	ATEX	EAC
Protection mode	Ex II 2/2G Ex h IIC T5, T4 Gb, Ex II 2/2D Ex h IIIC T100°C, T135°C Db	1Ex d IIC T5/T4 Gb X; Ex tb IIIC T100°C/T135°C Db X
Type examination certificate (1)	TUV CY 19 ATEX 026182X	RU C - IT.AЖ38.B.00425/21

(1) The type examination certificates can be downloaded from www.atos.com

Certification type	ATEX, EAC	
Pump version	(std and /PE)	/7 /PE
Temperature class	T5	T4
Surface temperature	≤ 100°C	≤ 135°C
Ambient temperature	-20 ÷ +60°C	-20 ÷ +70°C
Max inlet fluid temperature	+60°C	+80°C
Protection degree	IP 66	

⚠ WARNING: service work performed on the pump by the end users or not qualified personnel invalidates the certification

7.1 EXAMPLE OF PVPCA NAMEPLATE MARKING

 ROTATION			 atos Atos spa - Via alla Piana, 57 21018 Sesto Calende (Va) Italy
S. N°	220001		
M. N°	PVPCA-C-4046/1D **		
	TÜV CY 19 ATEX 0206182 X IP66		
	II 2/2G Ex h IIC T 5 Gb II 2/2D Ex h IIC T 100 °C Db		
TP TC 012/2011 	№ ВАЭС RU C-ПЛАЖ38.B.00425/21		Pin -0.2 ÷ 24 bar
	Серия RU N°0333507		Pmax 280 bar
	IEx d IIC T 5 Gb X		-20°C ≤ T _{oil} ≤ + 60 °C
	Ex tb IIC T 100 °C Db X		-20°C ≤ T _{amb} ≤ + 60 °C
			RPM 600 / 2600
Notified body and certificate number			
Marking according to Atex Directive			

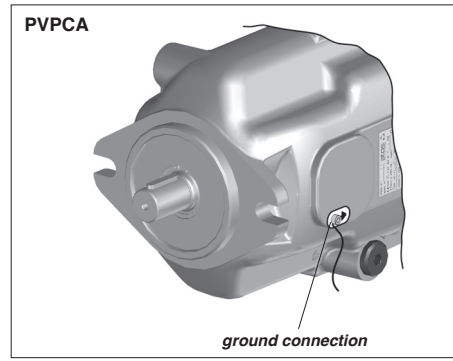

8 INSTALLATION POSITION

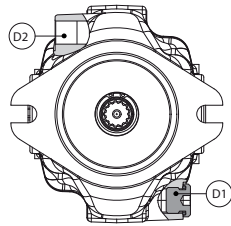
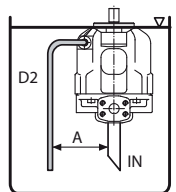
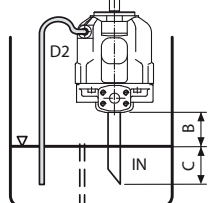
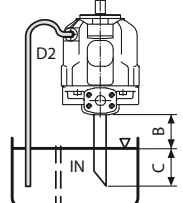
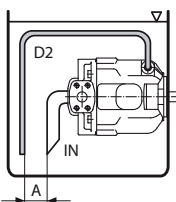
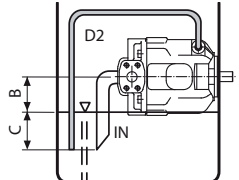
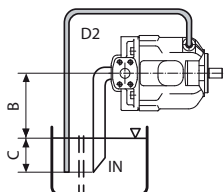
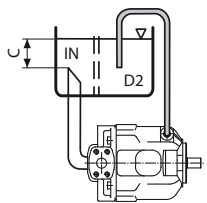
 <p>The pump is supplied with whit drain D2 open, and D1 plugged. Before installation fill the pump with hydraulic oil for at least 3/4 of its volume, keeping it in horizontal position. With exception of pump mounted below the oil level, we recommend to interpose a baffle plate between inlet and drain line.</p>	VERTICAL INSTALLATION		
	 <p>INSIDE THE TANK Minimum oil level equal or above the pump mounting surface. A ≥ 200mm</p>	 <p>INSIDE THE TANK Minimum oil level below the pump mounting surface. Minimum inlet pressure = 0,8 bar absolute B ≤ 800mm, C = 200mm</p>	 <p>OUTSIDE THE TANK, above oil level Minimum inlet pressure = 0,8 bar absolute B ≤ 800mm, C = 200mm</p>
HORIZONTAL INSTALLATION			
 <p>INSIDE THE TANK Minimum oil level equal or above the pump mounting surface. A ≥ 200mm</p>	 <p>INSIDE THE TANK Minimum oil level below the pump mounting surface. Minimum inlet pressure = 0,8 bar (absolute) B ≤ 800mm, C = 200mm</p>	 <p>OUTSIDE THE TANK, above oil level Minimum inlet pressure = 0,8 bar (absolute) B ≤ 800mm, C = 200mm</p>	 <p>OUTSIDE THE TANK, below oil level C = 200mm</p>

IN: inlet line - D1: drain line - A: minimum distance between inlet and drain line - B+C: permissible suction height - C: inlet line immersion dept

9 **DIAGRAMS at 1450 rpm (based on mineral oil ISO VG 46 at 50°C)**

9.1 Noise level curves

Ambient noise levels measured in compliance with ISO 4412-1 oleohydraulics -Test procedure to define the ambient noise level - Pumps
Shaft speed: 1450 rpm.

— = Qmax - - - - - = Qmin

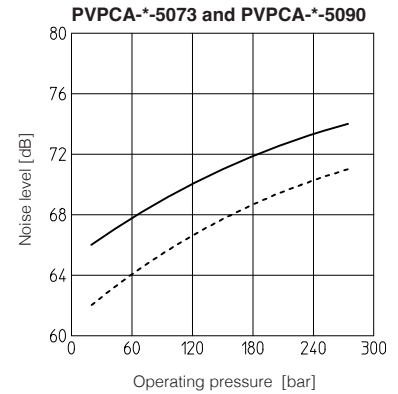
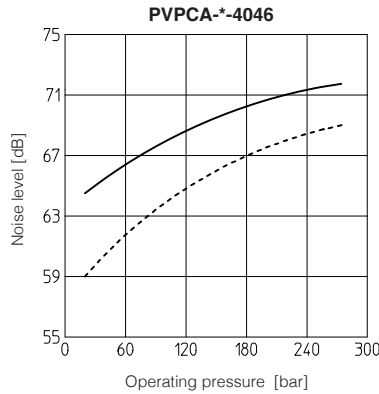
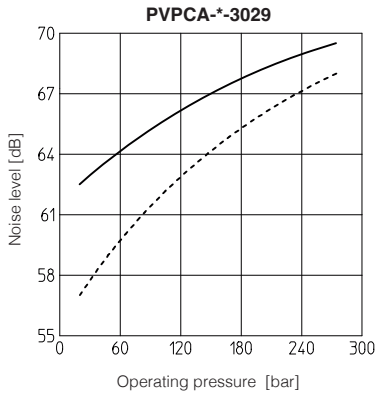

9.2 Operating limits

- 1** = Volumetric efficiency
- 2** = Overall efficiency
- 3** = Flow versus pressure curve
- 4** = Power consumption with full flow
- 5** = Power consumption at pressure compensation

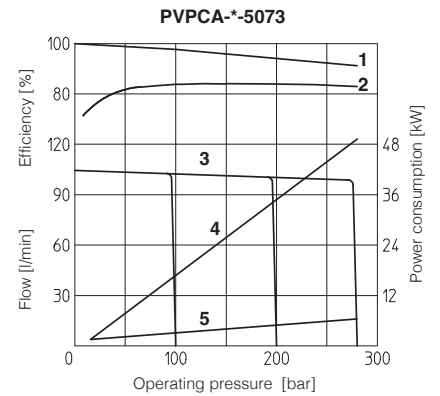
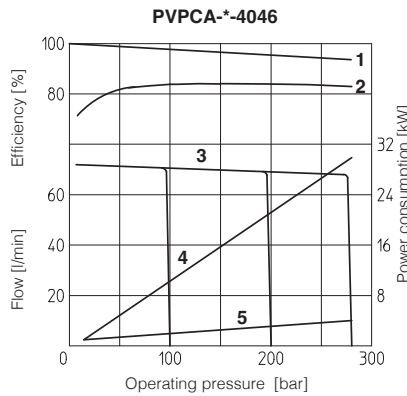
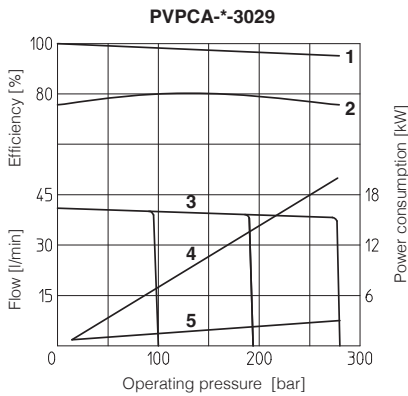

9.3 Response times

9.3.1 Response times and pressure peak due to variation 0% → 100% → 0% of the pump displacement, obtained with an instantaneous opening and shut-off of the delivery line.

Pump type	T1 (ms)	T2 (ms)
PVPCA-*-3029	31	19
PVPCA-*-4046	44	20
PVPCA-*-5073	50	25
PVPCA-*-5090	53	28

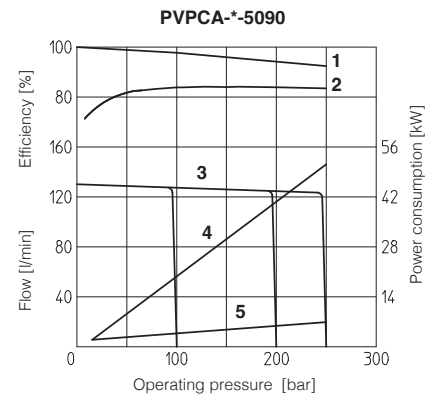
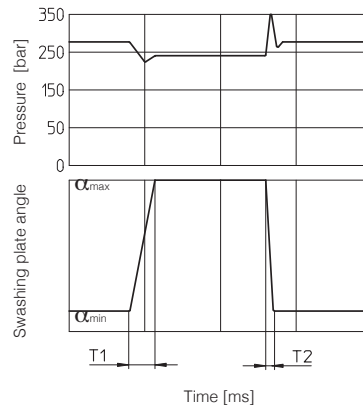

9.3.2 Variation of inlet pressure and reduction of displacement with increasing speed rating

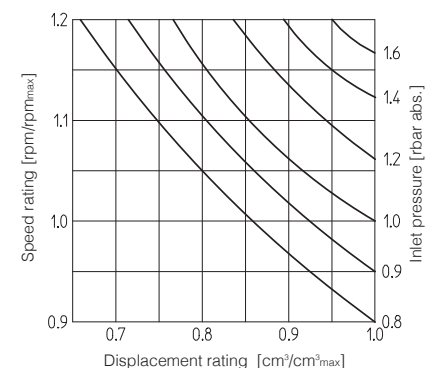

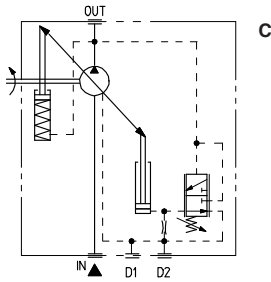

Manual pressure compensator

The pump displacement decreases when the line pressure approaches the setting pressure of the compensator. The pump supplies only the fluid required by the system. Pressure may be steplessly adjusted at the pilot valve.
 Compensator setting range: 20 ÷ 350 bar (315 bar for 090)
 Compensator standard setting: 280 bar (250 bar for 090)

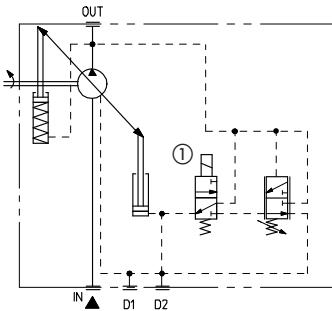
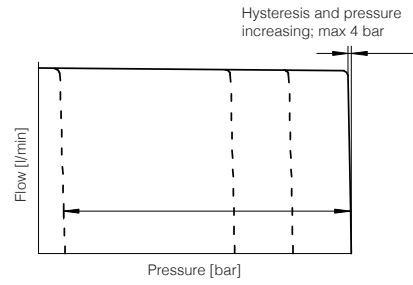

CH Manual pressure compensator with venting

As C plus venting function, when a long unloading time is required and heat generation and noise have to be kept at lowest level.
 Venting valve solenoid voltage, see section 5
 Venting valve OFF = null displacement
 Venting valve ON = max displacement
 Compensator setting range: 20 ÷ 350 bar (315 bar for 090)
 Compensator standard setting: 280 bar (250 bar for 090)

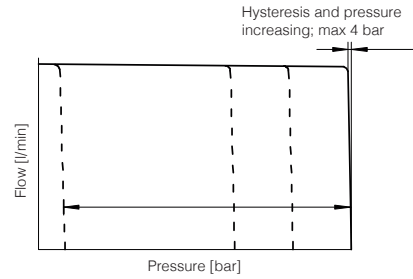

① solenoid venting valve

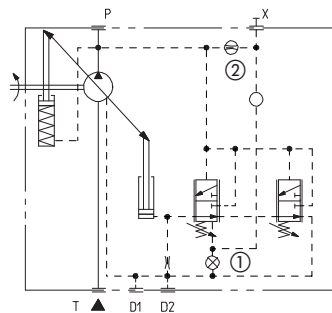

R Remote pressure compensator

As C, but with remote setting of the compensator by means of a pressure relief valve on the piloting line X.
 This version can be obtained from version L using a blind plug UNI 5923 M4x12 in pos. ① and a restrictor M4 drilled ø 0,75 mm in pos. ②.
 Compensator setting range: 20 ÷ 350 bar (315 bar for 090)
 Compensator standard setting: 280 bar (250 bar for 090)

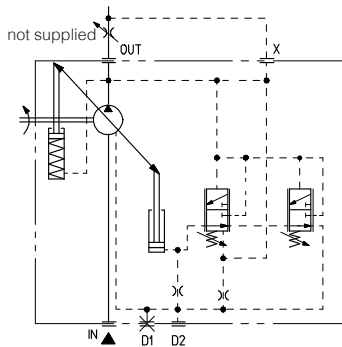
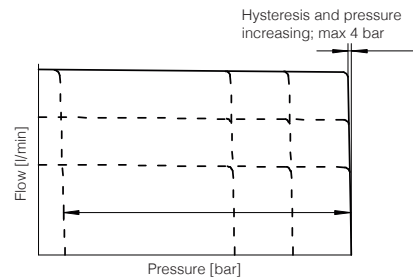

L Load sensing

The pump displacement is automatically adjusted to maintain a constant (load independent) pressure drop across an external throttle. Changing the throttle regulation, the pump flow is consequently adjusted.
 Load sensing control always incorporates an hydraulic compensator to limit the maximum pressure.
 Compensator setting range: 20 ÷ 350 bar (315 bar for 090)
 Compensator standard setting: 280 bar (250 bar for 090)
 Differential pressure setting range: 10 ÷ 40 bar
 Differential pressure standard setting: 14 bar

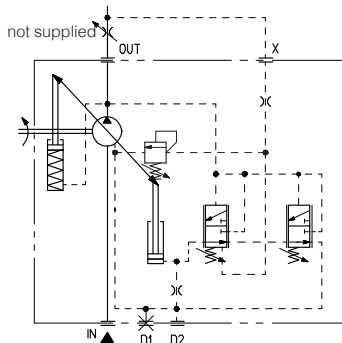
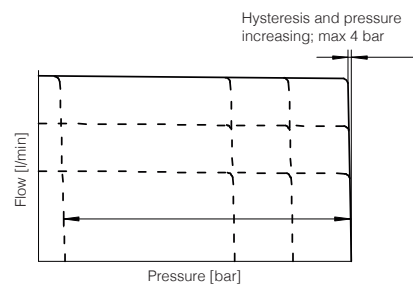

LW Constant power

In order to achieve a constant drive torque with varying operating pressure. The swashing angle and therefore the outlet flow is varied so that the product of flow and pressure remains constant.
 For the best regulation, minimum working pressure is 80 bar.
 While selecting LW control, the required value of power must be communicated with the order (ex. 10 kW at 1450 rpm).

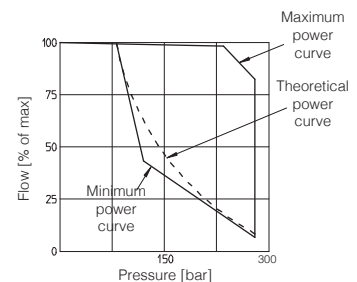

11 DIMENSIONS OF PVPCA-*-3029: BASIC VERSION "C" CONTROL

PORTS DIMENSION

IN = Flange SAE 3000 1 1/4"

OUT = Flange SAE 6000 3/4"

D1, D2 = 1/2" BSPP

① = Regulation screw for max displacement 1,5 cm³/rev per turn. Adjustable range 20 to 29 cm³/rev.
In case of double pump the regulation screw is not always available, please contact our technical office.

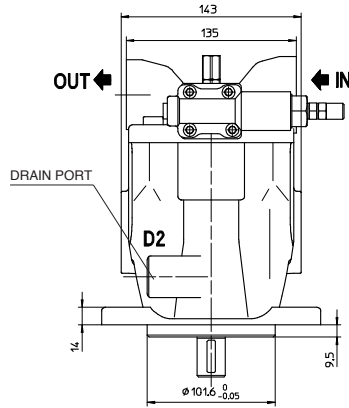
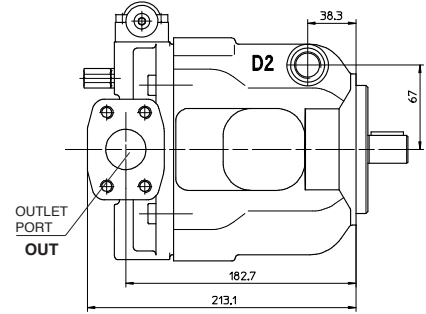
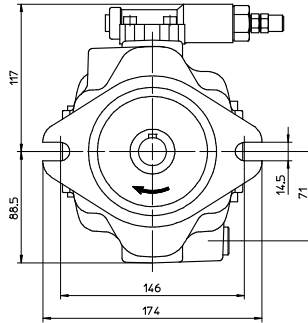
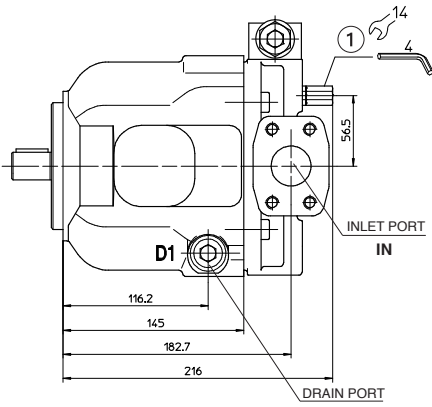

Mass: 18 kg

SHAFT TYPE "1"

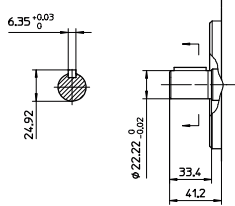

SHAFT TYPE "5"

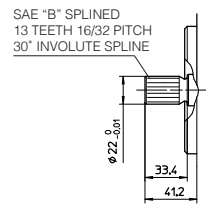

INTERMEDIATE FLANGE SAE "A" FOR PFEA-31

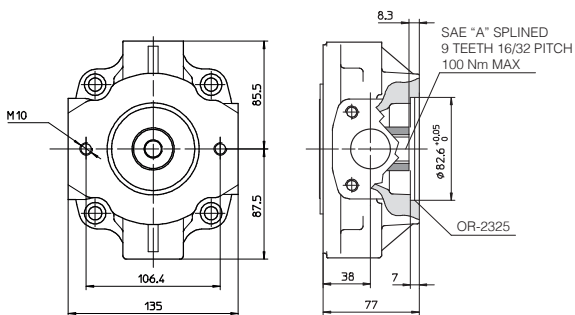

INTERMEDIATE FLANGE SAE "B" FOR PFEA-41

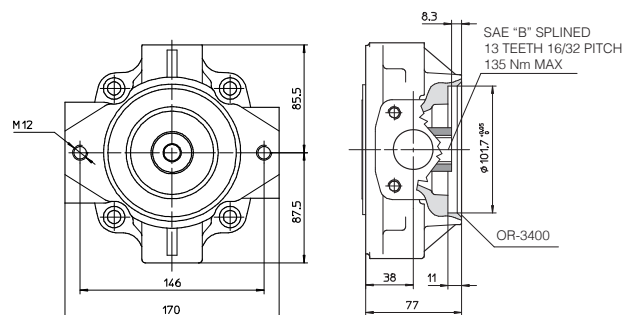

Drawing shows pumps with clockwise rotation (option D); pumps with counterclockwise rotation (option S) will have inlet and outlet ports inverted

12 DIMENSIONS OF PVPCA-*4046: BASIC VERSION "C" CONTROL

PORTS DIMENSION

IN = Flange SAE 3000 1 1/2"

OUT = Flange SAE 6000 1"

D1, D2 = 1/2" BSP

① = Regulation screw for max displacement 2,2 cm³/rev per turn. Adjustable range 31,8 to 46 cm³/rev.
 In case of double pump the regulation screw is not always available, please contact our technical office.

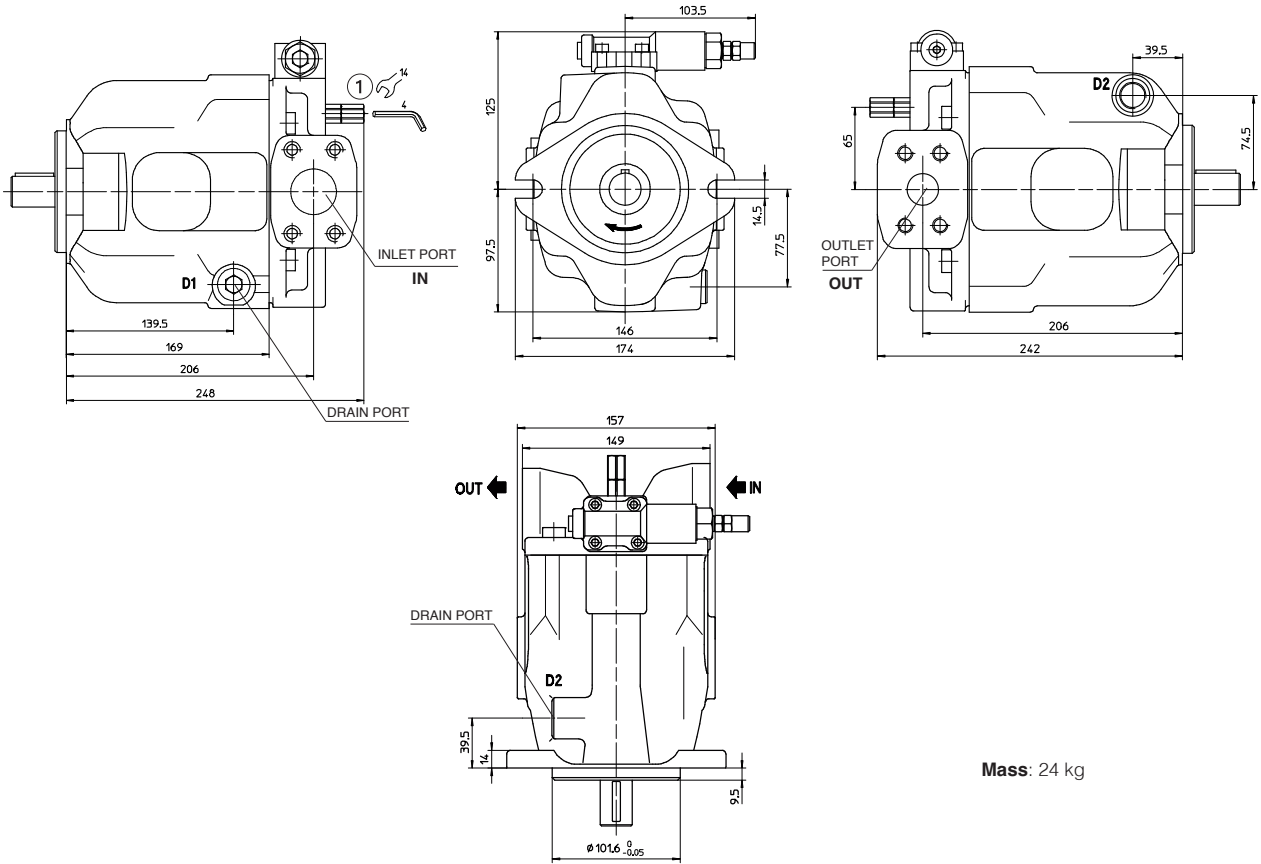

SHAFT TYPE "1"

SHAFT TYPE "5"

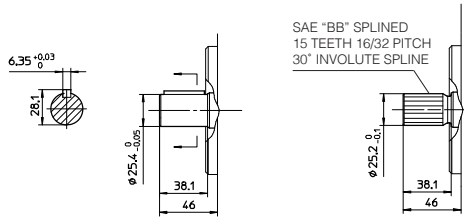

INTERMEDIATE FLANGE SAE "A" FOR PFEA-31

INTERMEDIATE FLANGE SAE "B" FOR PFEA-41

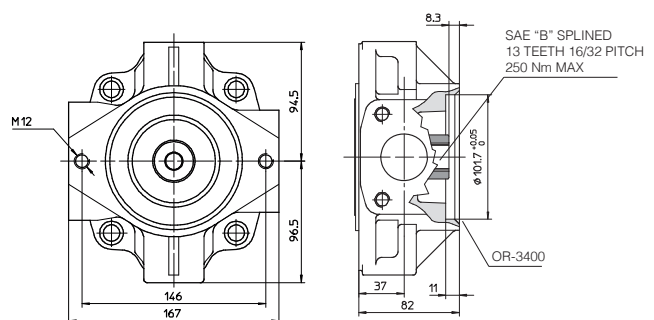
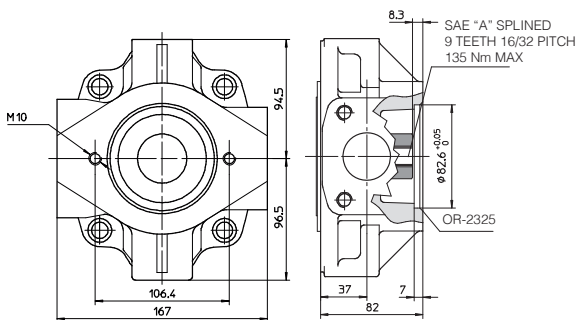

Drawing shows pumps with clockwise rotation (option D): pumps with counterclockwise rotation (option S) will have inlet and outlet ports inverted

13 DIMENSIONS OF PVPCA-*-5073 and PVPC-*-5090: BASIC VERSION "C" CONTROL

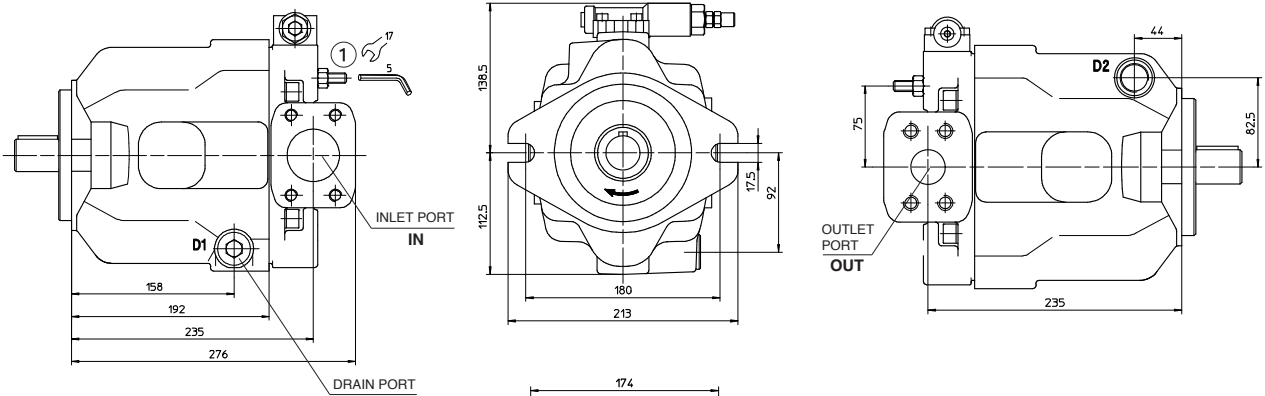

PORTS DIMENSION

IN = Flange SAE 3000 2"
 OUT = Flange SAE 6000 1 1/4"
 D1, D2 = 3/4" BSPP
 ① = Regulation screw for max displacement
 3,2 cm³/rev per turn.
 Adjustable range :
 PVPC-5073 = 36,8 to 46 cm³/rev
 PVPC-5073 = 44 to 88 cm³/rev.
 In case of double pump the regulation screw
 is not always available, please contact our
 technical office.

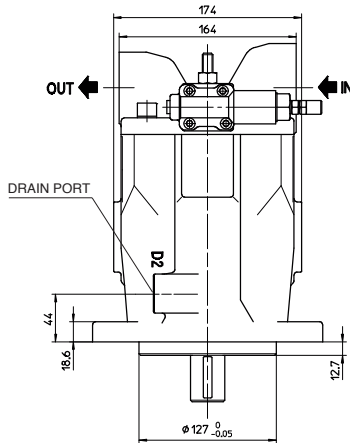

Mass: 33 kg

SHAFT TYPE "1"

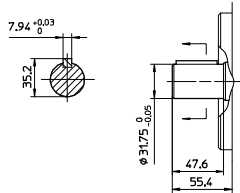

SHAFT TYPE "5"

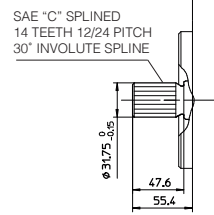

INTERMEDIATE FLANGE SAE "A" FOR PFEA-31

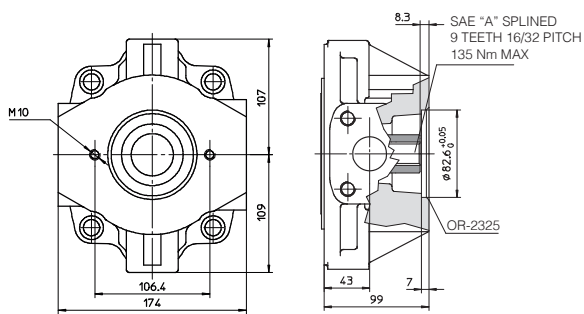

INTERMEDIATE FLANGE SAE "B" FOR PFEA-41

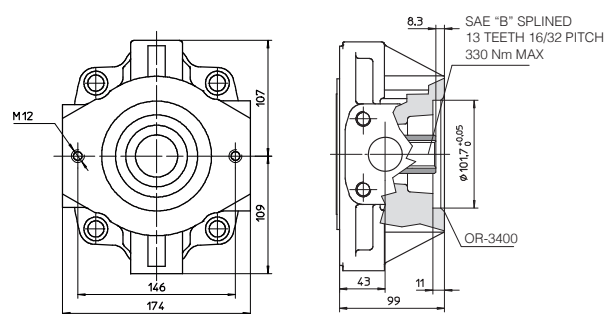

INTERMEDIATE FLANGE SAE "C" FOR PFEA-51

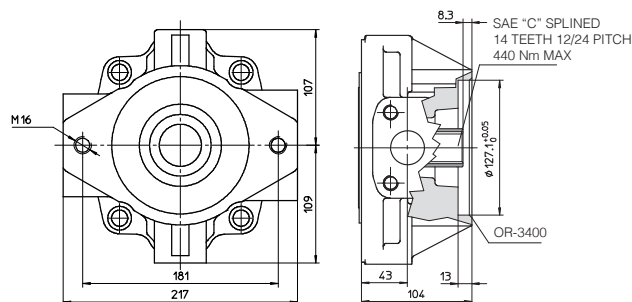

Drawing show pumps with clockwise rotation (option D); pumps with counterclockwise rotation (option S) will have inlet and outlet ports inverted

14 DIMENSIONS OF PVPCA: OTHER CONTROLS

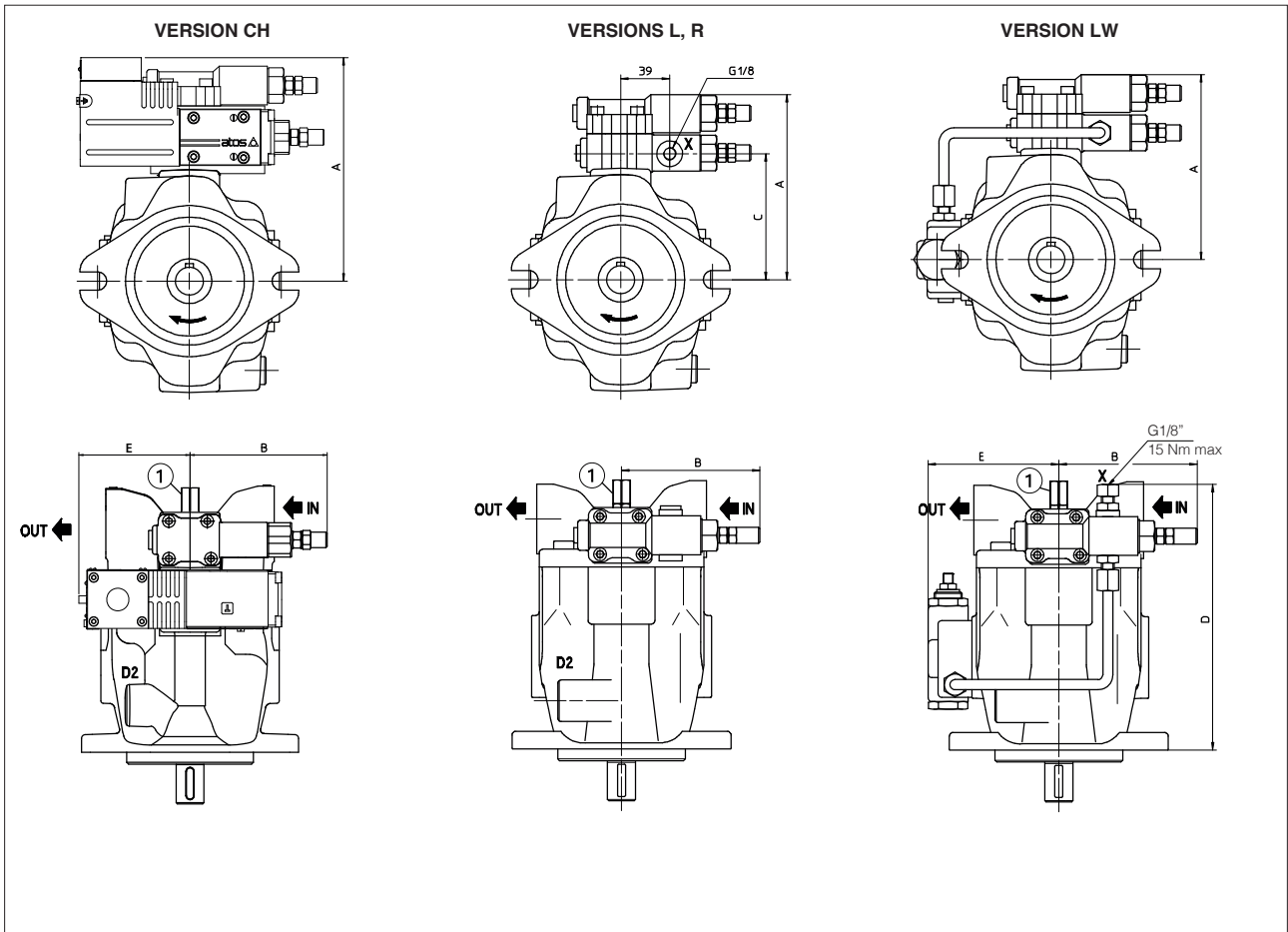

① = Regulation screw for max displacement. Adjustable range 50% to 100% of max displacement).
 In case of double pump the regulation screw is not always available, please contact our technical office.

Drawing shows pumps with clockwise rotation (option D); pumps with counterclockwise rotation (option S) will have inlet and outlet ports inverted and also the consequently position of the control groups

Pump type	Version	A	B	C	D	E	Mass (kg)
PVPCA-*-3029	CH	144	111	-	-	92	22
	L-R	144	111	100	-	-	19,2
	LW	144	111	-	211	104	20
PVPCA-*-4046	CH	153	111	-	-	92	28
	L-R	153	111	109	-	-	25,2
	LW	153	111	-	235	111	26
PVPCA-*-5073	CH	166	111	-	-	92	36,9
	L-R	166	111	122	-	-	34,2
PVPCA-*-5090	LW	166	111	-	258	120	35

15 RELATED DOCUMENTATION

- X010** Basics for electrohydraulics in hazardous environments
- X020** Summary of Atos ex-proof components certified to ATEX, IECEx, EAC, PESO
- AX900** Operating and maintenance information for ex-proof pumps