

Pressure relief valves type REM

two stage, flange mounting SAE 3/4", 1", 1 1/4"

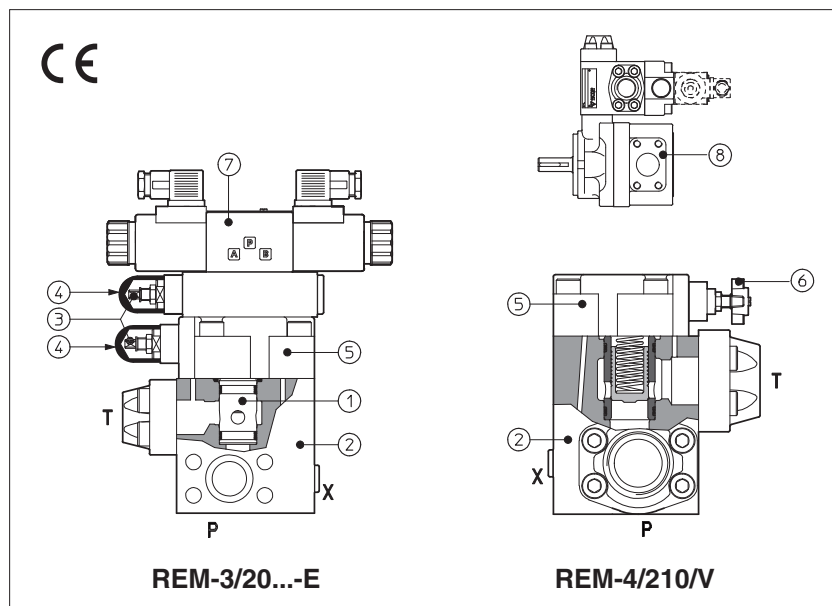

REM are two stage pressure relief valves with balanced poppet and SAE flange connection, designed to operate in oil hydraulic systems.

They can be directly mounted with SAE flange attachments on the pumps outlet ports ⑧ and, in particular, on the PFE pumps (see tab. A005, A007).

In standard versions the piloting pressure of the poppet ① of the main stage ② is regulated by means of a grub screw ③ protected by cap ④ in the cover ⑤.

Optional versions with setting adjustment by handwheel ⑥ instead of the grub screw are available on request.

Clockwise rotation increases the pressure. REM can be equipped with a venting solenoid valve ⑦ type:

- DHE for AC and DC supply, high performances, with **cURus** certified solenoids
- DHL for AC and DC supply, compact execution

Mounting surface:

SAE flange connection: **3/4", 1", 1 1/4"**

Max flow: **200, 400 and 600 l/min** respectively

Pressure up to **350 bar**

1 MODEL CODE

REM	-	4	/	20		210	/	100/100	/	V	-	E		X		24DC	**	/	*
REM = pressure relief valve SAE flange mounting Size: 3 = SAE 3/4" 4 = SAE 1" 5 = SAE 1 1/4"																		Seals material, see section 7: - = NBR PE = FKM BT = HNBR Series number	
Setting pressure and venting option (1): - = one setting pressure without option 10 = one setting pressure with venting, with de-energized solenoid 11 = one setting pressure with venting, with energized solenoid 20 = two setting pressure with venting, with de-energized solenoid 21 = two setting pressure with venting, with energized solenoid 22 = two setting pressure without venting 32 = three setting pressure without venting																		Voltage code, see section 7	
Pressure range: 50 = 4÷50 bar; 100 = 6÷100 bar; 210 = 7÷210 bar; 350 = 8÷350 bar (only for REM-3)																		X = without connector (1): See section 10 for available connectors, to be ordered separately -00-AC = AC solenoid valve without coils -00-DC = DC solenoid valve without coils	
Pressure range of second/third setting (1): 50 = 4÷50 bar; 100 = 6÷100 bar; 210 = 7÷210 bar; 350 = 8÷350 bar (only for REM-3)																		Pilot valve (1): E = DHE for AC and DC supply, high performances with cURus certified solenoids L = DHL for AC and DC supply, compact execution	
																		Options (2): WP = prolonged manual override protected by rubber cap (1) V = regulating by handwheel instead of a grub screw protected by cap	

(1) Only for REM with solenoid valve for venting and/or for the selection of the setting pressure

(2) For handwheel features, see technical table K150

2 HYDRAULIC CHARACTERISTICS

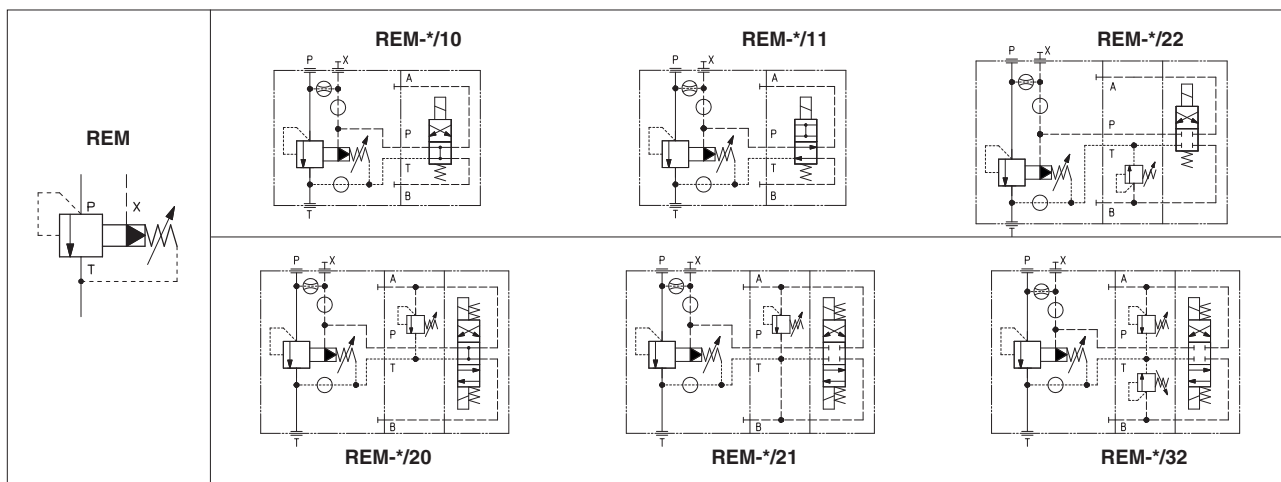

3 GENERAL CHARACTERISTICS

Assembly position	Any position
Subplate surface finishing to ISO 4401	Acceptable roughness index, Ra ≤ 0,8 recommended Ra 0,4 - flatness ratio 0,01/100
MTTFd valves according to EN ISO 13849	75 years, see technical table P007
Ambient temperature range	Standard = -30°C ÷ +70°C /PE option = -20°C ÷ +70°C /BT option = -40°C ÷ +70°C
Storage temperature range	Standard = -30°C ÷ +80°C /PE option = -20°C ÷ +80°C /BT option = -40°C ÷ +80°C
Surface protection	Body: zinc coating with black passivation Coil: zinc nickel coating (DC version) plastic encapsulation (AC version)
Corrosion resistance	Salt spray test (EN ISO 9227) > 200 h
Compliance	CE to Low Voltage Directive 2014/35/EU RoHS Directive 2011/65/EU as last update by 2015/863/EU REACH Regulation (EC) n°1907/2006

4 HYDRAULIC CHARACTERISTICS

Valve model	REM-3	REM-4	REM-5
Max flow [l/min]	200	400	600
Pressure range [bar]	4-50; 6-100; 7-210; 8-350	4÷50; 6÷100; 7÷210	
Max pressure [bar]	Ports P, X= 350 Port T= 210 without pilot solenoid valve, for version -EX and -LX, see tech tables E015 and E018		

5 ELECTRICAL CHARACTERISTICS (for ARAM with pilot solenoid valve)

Insulation class	H (180°C) for DC coils; F (155°C) for AC coils Due to the occurring surface temperatures of the solenoid coils, the European standards EN ISO 13732-1 and EN ISO 4413 must be taken into account
Protection degree to DIN EN 60529	IP 65 (with connectors correctly assembled)
Relative duty factor	100%
Supply voltage and frequency	See section 7
Supply voltage tolerance	± 10%
Certification	cURus North American standard - only for DHE pilot valve

6 SEALS AND HYDRAULIC FLUID - for other fluids not included in below table, consult our technical office

Seals, recommended fluid temperature	NBR seals (standard) = -20°C ÷ +80°C, with HFC hydraulic fluids = -20°C ÷ +50°C FKM seals (/PE option) = -20°C ÷ +80°C HNBR seals (/BT option) = -40°C ÷ +60°C, with HFC hydraulic fluids = -40°C ÷ +50°C		
Recommended viscosity	15÷100 mm ² /s - max allowed range 2,8 ÷ 500 mm ² /s		
Max fluid contamination level	ISO4406 class 20/18/15 NAS1638 class 9, see also filter section at www.atos.com or KTF catalog		
Hydraulic fluid	Suitable seals type	Classification	Ref. Standard
Mineral oils	NBR, FKM, HNBR	HL, HLP, HLPD, HVL, HVLDP	DIN 51524
Flame resistant without water	FKM	HFDR, HFDR	ISO 12922
Flame resistant with water	NBR, HNBR	HFC	

7 COIL VOLTAGE

External supply nominal voltage ± 10%	Voltage code	Type of connector	-EX Power consumption (2)	-LX Power consumption (2)	Code of spare coil -EX	Code of spare coil -LX
12 DC	12 DC	666 or 667	30W	29W	COE-12DC	COL-12DC
14 DC	14 DC				COE-14DC	COL-14DC
110 DC	110 DC				COE-110DC	COL-110DC
220 DC	220 DC				COE-220DC	COL-220DC
110/50 AC (1)	110/50/60 AC	666 or 667	58VA (3)	58VA (3)	COE-110/50/60AC	COL-110/50/60AC
115/60 AC	115/60 AC		80VA (3)		COE-115/60AC	COL-115/60AC
230/50 AC (1)	230/50/60 AC		58VA (3)		COE-230/50/60AC	COL-230/50/60AC
230/60 AC	230/60 AC		80VA (3)		COE-230/60AC	COL-230/60AC

(1) For other supply voltages available on request see technical tables E015, E018.

(2) Coil can be supplied also with 60 Hz of voltage frequency: in this case the performances are reduced by 20 ÷ 25% and the power consumption is 55 VA (DHL) and 58 VA (DHE)

(3) Average values based on tests performed at nominal hydraulic condition and ambient/coil temperature of 20°C.

(4) When solenoid is energized, the inrush current is approx 3 times the holding current.

8 REGULATED PRESSURE VERSUS FLOW DIAGRAMS based on fluid viscosity of 25 mm²/s at 40°C

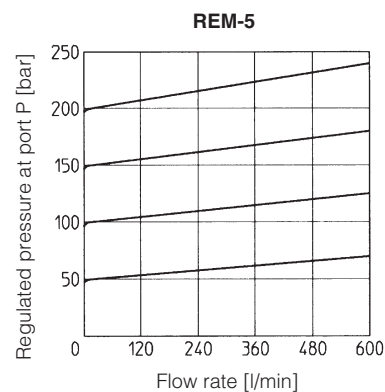
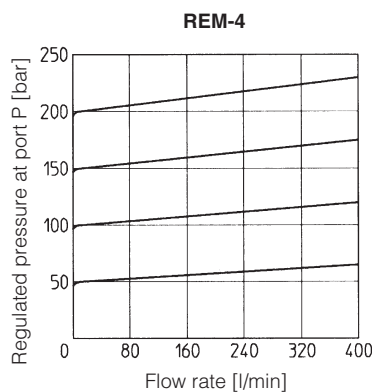
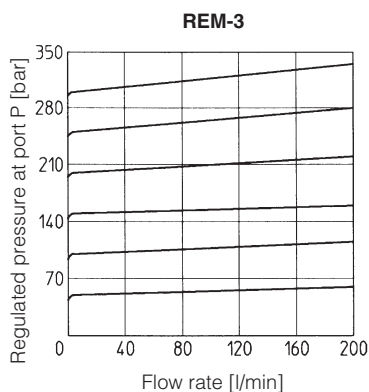

9 MINIMUM PRESSURE VERSUS FLOW DIAGRAMS based on fluid viscosity of 25 mm²/s at 40°C

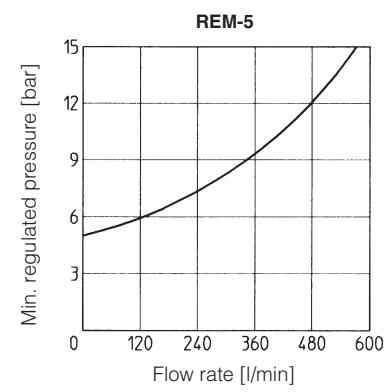
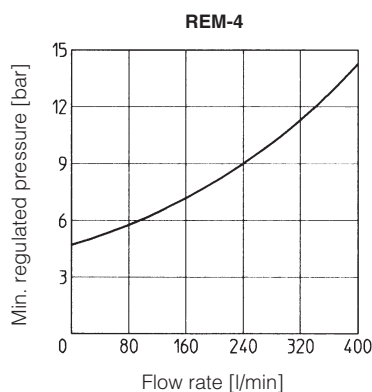
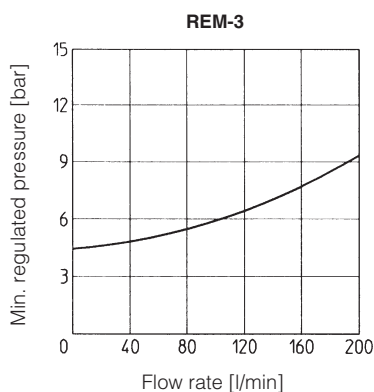

10 ELECTRIC CONNECTORS ACCORDING TO DIN 43650 for REM with solenoid valve (to be ordered separately, see tech table K800)

666 = standard connector IP-65, suitable for direct connection to electric supply source

667 = as 666, but with built-in signal led. Available for power supply voltage 24 AC or DC, 110 AC or DC, 220 AC or DC

REM-3-*-EX

Flange type WFD-20

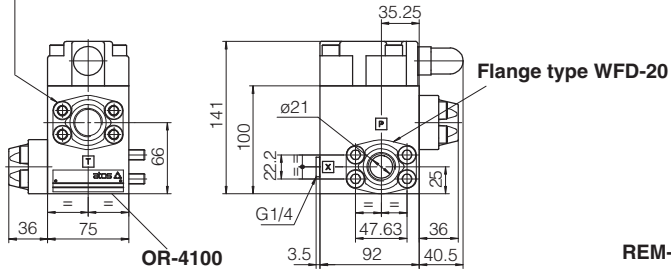

OR-4100

Mass: 6,6 Kg

REM-3/10/**-EX
REM-3/11/**-EX

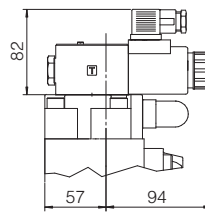

Mass: 8,1 Kg

REM-3/20/**-EX
REM-3/21/**-EX

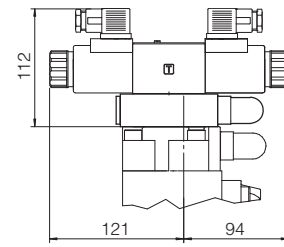

Mass: 9,2 Kg

REM-3/22/**-EX

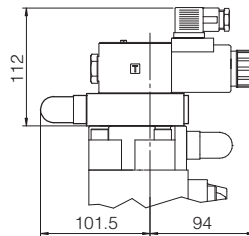

Mass: 8,9 Kg

REM-3/32/**-EX

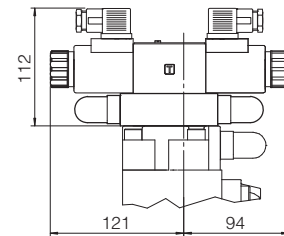

Mass: 9,3 Kg

REM-3-*-LX

Flange type WFD-20

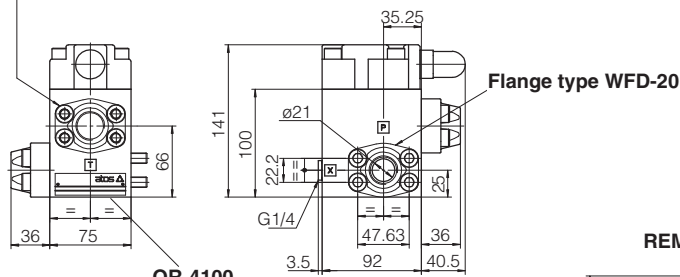

OR-4100

Mass: 6,6 Kg

REM-3/10/**-LX
REM-3/11/**-LX

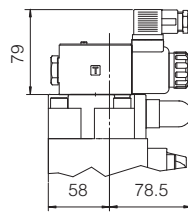

Mass: 7,9 Kg

REM-3/20/**-LX
REM-3/21/**-LX

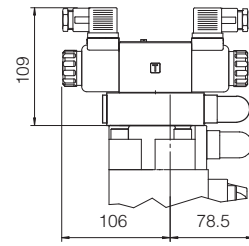

Mass: 8,8 Kg

REM-3/22/**-LX

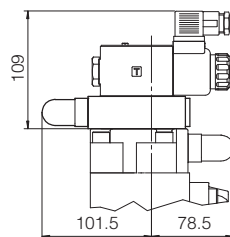

Mass: 8,7 Kg

REM-3/32/**-LX

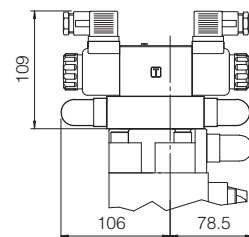

Mass: 8,9 Kg

REM-4*-EX

REM-4/10-EX
REM-4/11**-EX**

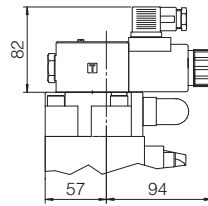

Mass: 8,3 Kg

REM-4/20-EX
REM-4/21**-EX**

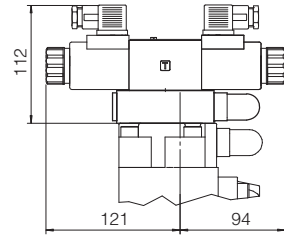

Mass: 9,4 Kg

Flange type WFD-25

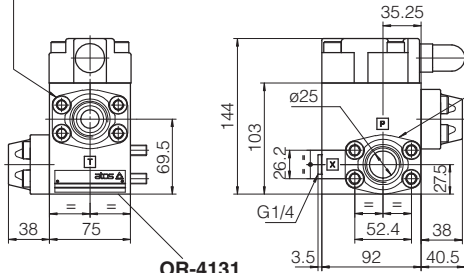

OR-4131

Mass: 6,8 Kg

Flange type WFD-25

REM-4/22-EX**

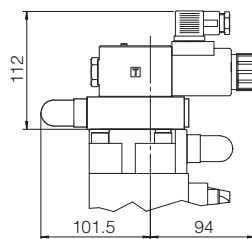

Mass: 9,1 Kg

REM-4/32-EX**

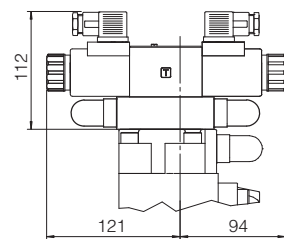

Mass: 9,5 Kg

REM-4*-LX

REM-4/10-LX
REM-4/11**-LX**

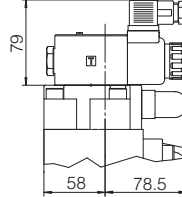

Mass: 8,1 Kg

REM-4/20-LX
REM-4/21**-LX**

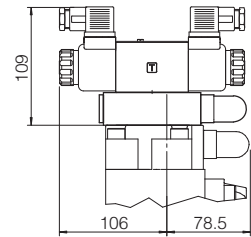

Mass: 9 Kg

Flange type WFD-25

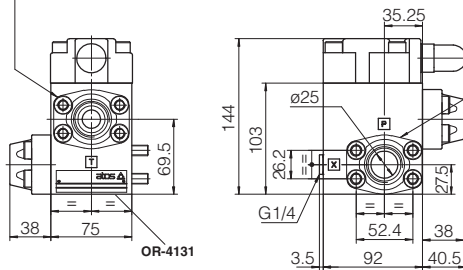

OR-4131

Mass: 6,8 Kg

Flange type WFD-25

REM-4/22-LX**

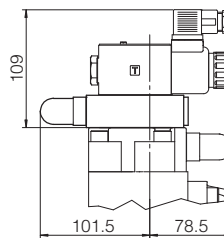

Mass: 8,9 Kg

REM-4/32-LX**

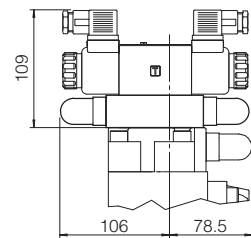

Mass: 9,1 Kg

REM-5-*-EX

Flange type WFD-32

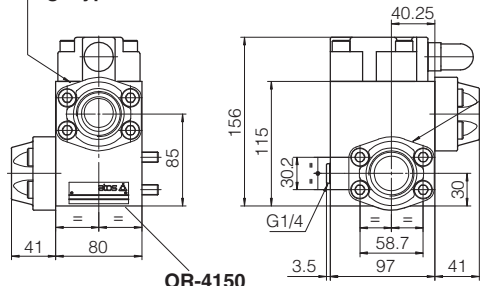

OR-4150

Mass: 8,2 Kg

Flange type WFD-32

REM-5/10/-EX
REM-5/11/**-EX**

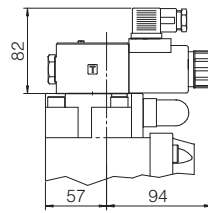

Mass: 9,7 Kg

REM-5/20/-EX
REM-5/21/**-EX**

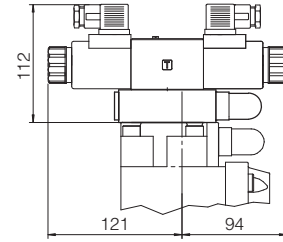

Mass: 10,8 Kg

REM-5/22/-EX**

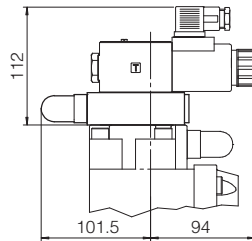

Mass: 10,5 Kg

REM-5/32/-EX**

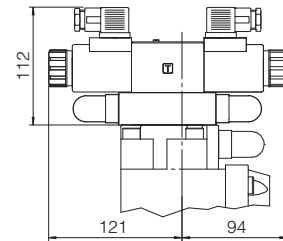

Mass: 10,9 Kg

REM-5-*-LX

Flange type WFD-32

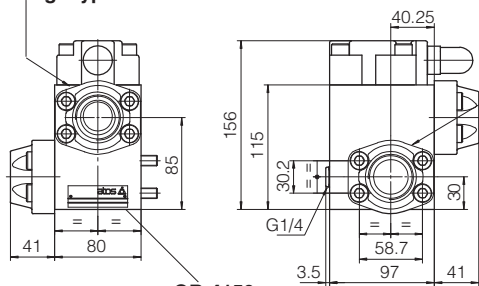

OR-4150

Mass: 8,2 Kg

Flange type WFD-32

REM-5/10/-LX
REM-5/11/**-LX**

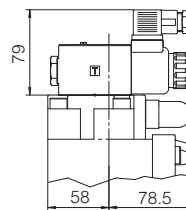

Mass: 9,5 Kg

REM-5/20/-LX
REM-5/21/**-LX**

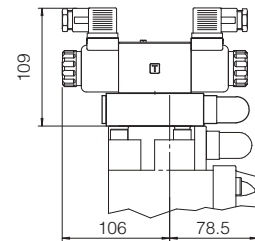

Mass: 10,4 Kg

REM-5/22/-LX**

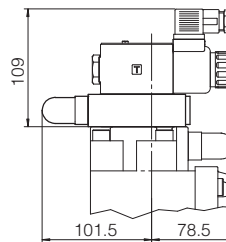

Mass: 10 Kg

REM-5/32/-LX**

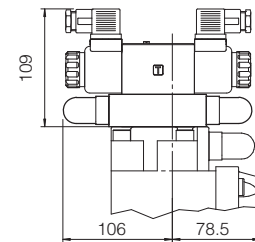

Mass: 10,5 Kg

Overall dimensions refer to valves **DC** voltage, with connectors type 666

12 ASSEMBLY EXAMPLE OF A REM VALVE ON A PFE PUMP

LATERAL VIEW OF PUMP

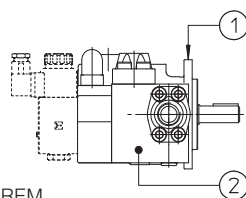

REAR VIEW OF PUMP

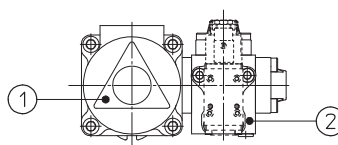

TOP VIEW OF PUMP

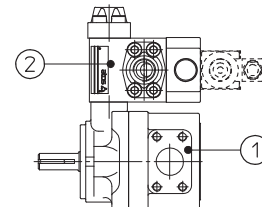

- ① Pump type PFE
- ② Relief valve type REM