

Cartridge check valves type DB, DR

screw-in mounting - from G1/4" to G1/2"

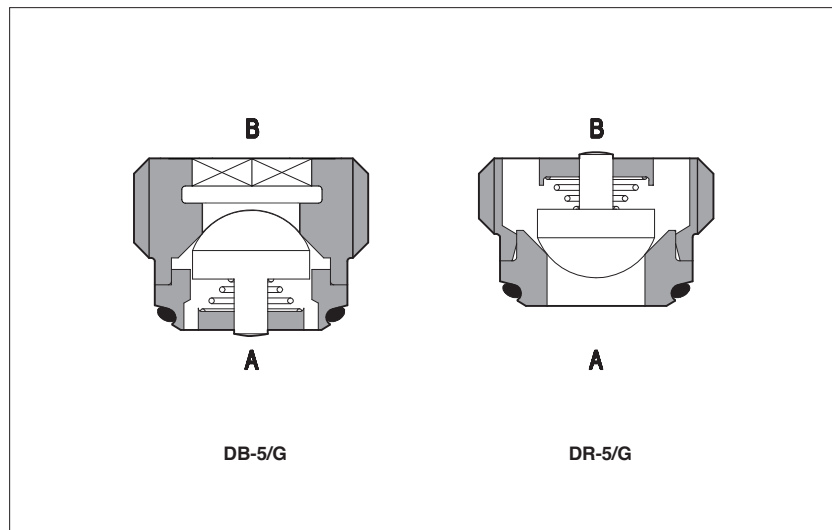

DB, DR are direct operated check valves for screw-in mounting in cavities from G1/4" to G1/2".

They are specifically designed to reduce the manifold dimensions and simplify the installation.

Cartridge designed to operate in hydraulic systems with hydraulic mineral oil or synthetic fluid having similar lubricating characteristics.

Flow up to **95 l/min.**

Max pressure: **350 bar**

1 MODEL CODE

D	B	-	10	/	G	**	/	*
Screw-in check valve						Series number		Seals material, see section 3:
B = function A B R = function B A								- = NBR PE = FKM BT = HNBR
Size/threated connections:								
5 = G 1/4"	10 = G 3/8"		15 = G 1/2"		G = Gas threading			

2 HYDRAULIC CHARACTERISTICS

Hydraulic symbol	DB-*/G			DR-*/G		
Valve model	DB-5/G	DR-5/G	DB-10/G	DR-10/G	DB-15/G	DR-15/G
Nominal flow (at Δp = 8 bar) [l/min]	25	35	55	65	85	95
Max pressure [bar]	350					
Cracking pressure [bar]	0,3					

3 MAIN CHARACTERISTICS, SEALS AND FLUIDS - for other fluids not included in below table, consult our technical office

Assembly position	Assembly position		
Compliance	RoHS Directive 2011/65/EU as last update by 2015/65/EU REACH Regulation (EC) n°1907/2006		
Ambient temperature	Standard = -30°C ÷ +70°C /PE option = -20°C ÷ +70°C /BT option = -40°C ÷ +70°C		
Seals, recommended fluid temperature	NBR seals (standard) = -20°C ÷ +80°C, with HFC hydraulic fluids = -20°C ÷ +50°C FKM seals (/PE option) = -20°C ÷ +80°C HNBR seals (/BT option) = -40°C ÷ +60°C, with HFC hydraulic fluids = -40°C ÷ +50°C		
Recommended viscosity	15 ÷ 100 mm ² /s - max allowed range 2,8 ÷ 500 mm ² /s		
Max fluid contamination level	ISO4406 class 20/18/15 NAS1638 class 9, see also filter section at www.atos.com or KTF catalog		
Flow direction	As shown in the symbol at section 2		
Rated flow	See diagrams Q/Δp at section 4		
Hydraulic fluid	Suitable seals type	Classification	Ref. Standard
Mineral oils	NBR, FKM, HNBR	HL, HLP, HLPD, HVL, HVLDP	DIN 51524
Flame resistant without water	FKM	HFDR, HFDR	ISO 12922
Flame resistant with water	NBR, HNBR	HFC	

4 FLOW VERSUS PRESSURE DROP DIAGRAMS based on mineral oil ISO VG 46 at 50°C

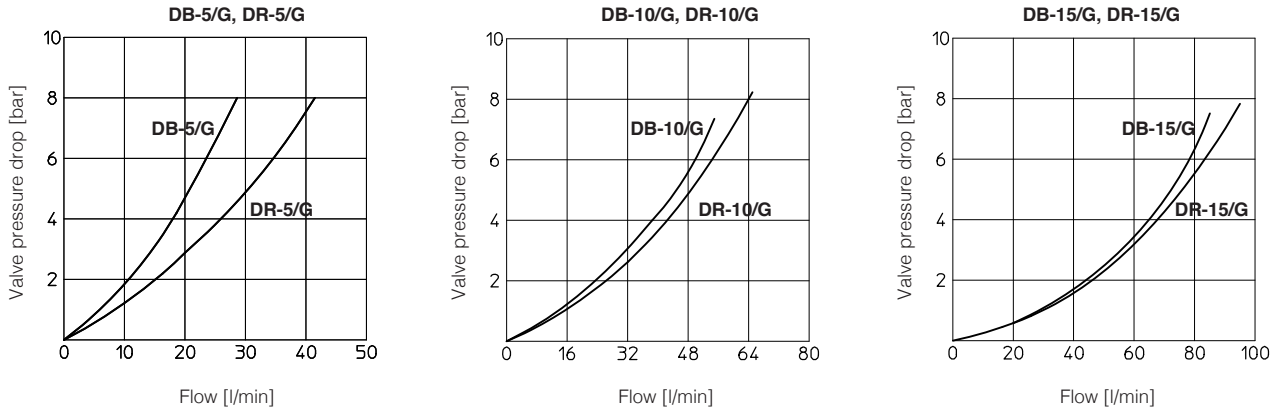

5 RECESS DIMENSIONS [mm]

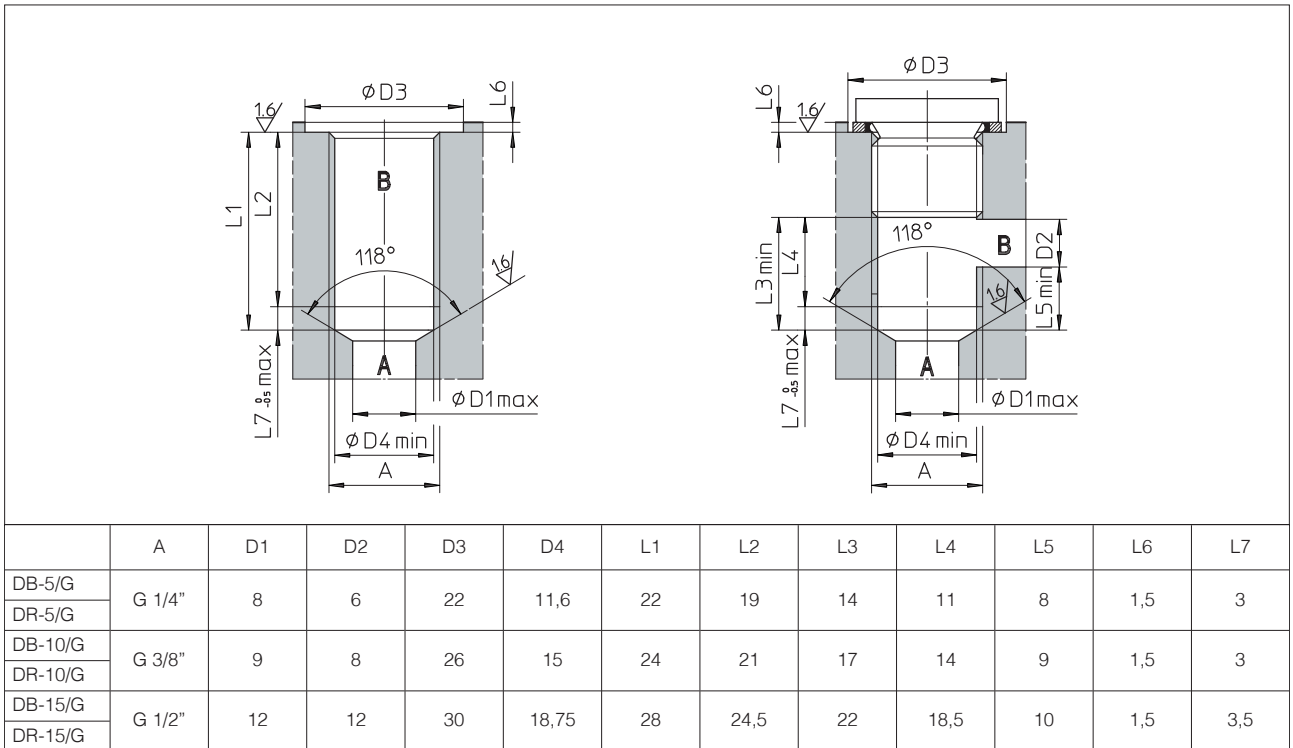

6 VALVE DIMENSIONS [mm]

