

Stainless steel pressure relief valves

direct, screw-in cartridges

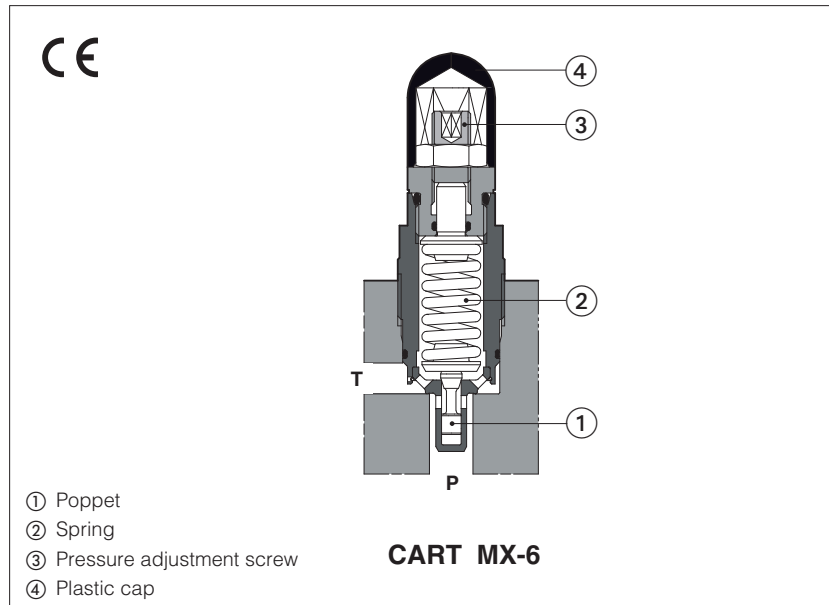

CART-MX(S), CART-AREX(S)

Screw-in, direct operated pressure relief valves used to limit the max pressure in the hydraulic systems or to protect part of the circuit from overpressure.

The cartridge design reduces the dimension of blocks and manifolds, without penalizing the functional characteristics.

They are available in three sizes and in two different stainless steel executions for corrosive environments and fluids.

- X** full stainless steel for external and internal parts, to withstand extreme and corrosive environmental conditions, and to ensure full compatibility also with water base and special fluids.
- XS** stainless steel only for external parts to withstand extreme and corrosive environmental conditions.

Size: **G1/2" ÷ M35**

Max flow: **2,5 ÷ 120 l/min**

Max pressure: up to **420 bar**

1 MODEL CODE OF SCREW-IN VALVES

CART	AREX-20	/	350	/	R	/	*	/	*	/	*
Screw-in pressure relief cartridge											Test fluid , only for X execution: (3) H = mineral oil W = pure water
Size and stainless steel execution (1) :											
MX-3, MXS-3 = G1/2"											
MX-6, MXS-6 = M33x1,5											
AREX-20, AREXS-20 = M35x1,5											
Max pressure settings: see hydraulic characteristics in section (4)											
R = reduced leakage for special applications only for CART AREX-20 and CART AREXS-20 (2)											
Series number											
Seals material , see section (5) : - = NBR low temp. -40°C PE = FKM BBT = FVMQ fluorosilicon -60°C (4)											

For **PED** safety version see technical table CWY010

- (1) X** = Full stainless steel
XS = Stainless steel only for external parts

See section **(5)** for material specification

(2) Code **R** must be always reported in the model code of CART AREX-20 and CART AREXS-20

(3) CART MX and CART AREX in full stainless steel execution are factory tested with mineral oil or pure water in order to avoid the contamination of the end user system. At the end of each valve model code must be specified the type of fluid to be used in the valve's testing: "**H**" for hydraulic oil or "**W**" for pure water.

(4) Only for full stainless steel "**X**" execution

2 HYDRAULIC SYMBOLS

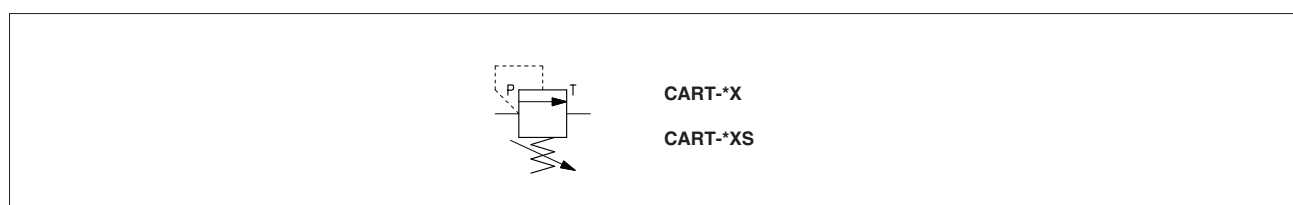

3 GENERAL CHARACTERISTICS

Assembly position / location	Any position
Cavity	See section 8
MTTFd values according to EN ISO 13849	150 years, for further details see technical table P007
Ambient temperature	Standard = -40°C ÷ +70°C /PE option = -20°C ÷ +70°C /BBT option = -60°C ÷ +70°C
Storage temperature range	Standard = -40°C ÷ +80°C /PE option = -20°C ÷ +80°C /BBT option = -60°C ÷ +80°C
Compliance	RoHS Directive 2011/65/EU as last update by 2015/863/EU REACH Regulation (EC) n°1907/2006

4 HYDRAULICS CHARACTERISTICS

Valve model		CART MX-3 CART MXS-3	CART MX-6 CART MXS-6	CART AREX-20 CART AREXS-20
Max pressure setting [bar]		50, 100, 210, 350, 420	50, 100, 210, 350, 420	50, 100, 210, 315, 400
Pressure range (1) [bar]		4÷50, 6÷100, 7÷210, 8÷350, 15÷420	2÷50, 3÷100, 8÷210, 15÷350, 15÷420	3÷50, 5÷100, 6÷210, 8÷315, 10÷400
Max flow [l/min]		2,5	40	120

(1) The values correspond to the min and max regulation of the valve's craking pressure

5 MATERIALS SPECIFICATION

Valve code	Valve type	Valve body	Internal parts	Spring	Seals		
					std	/PE	/BBT
CART-X	Screw-in	AISI 316L	AISI 316L, 420B, 440C	AISI 302	NBR 70 Sh low temp	FKM (viton)	FMVQ (fluorosilicon)
CART-XS	Screw-in	AISI 316L	Carbon steel	AISI 302	NBR 70 Sh low temp	FKM (viton)	-

6 SEALS AND HYDRAULIC FLUIDS - for other fluids not included in below table, consult our technical office

Seals, recommended fluid temperature (1)	NBR seals (standard) = -40°C ÷ +60°C FKM seals (/PE option) = -20°C ÷ +80°C FVMQ seals (/BBT option) = -60°C ÷ +60°C		
Recommended viscosity	15÷100 mm ² /s - max allowed range 2.8 ÷ 500 mm ² /s min = 0,9 mm ² /s for X full stainless steel execution with pure water		
Max fluid contamination level	ISO4406 class 20/18/15 NAS1638 class 9, see also filter section at www.atos.com or KTF catalog		
Hydraulic fluid	Suitable seals type	Classification	Ref. Standard
Mineral oils	NBR low temp., FKM, FVMQ	HL, HLP, HLPD, HVLP, HVLDP	DIN 51524
Flame resistant without water	FKM, FVMQ	HFDU, HFDR	ISO 12922
Flame resistant with water	NBR low temp.	HFA-E, HFA-S, HFB, HFC	

(1) The operating temperature of the fluid must be compatible with the maximum viscosity range allowed for the valve

7 REGULATED PRESSURE VS FLOW DIAGRAMS (based on mineral oil ISO VG 46 at 50°C)

CART MX(S)-3

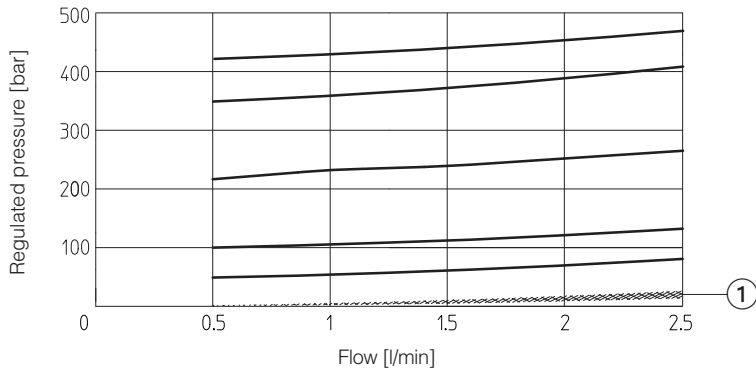

CART MX(S)-6

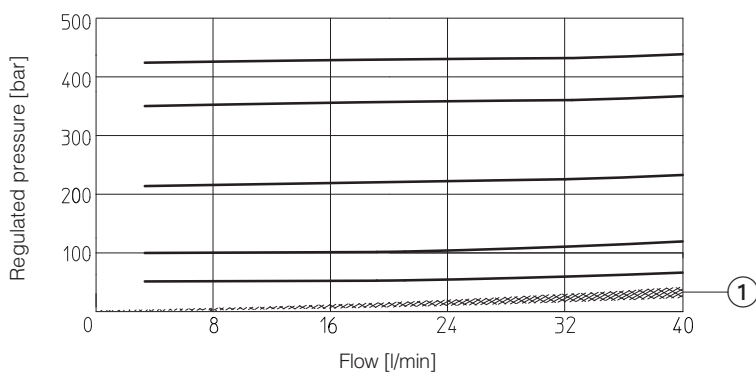

CART AREX(S)-20 **/R

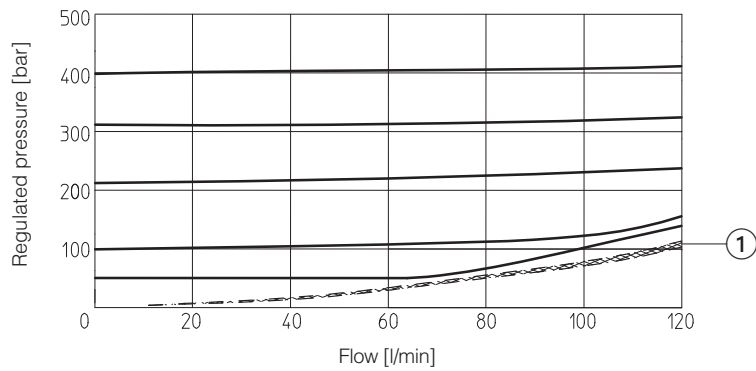

① Minimum pressure with the adjustment screw fully unscrewed

8 CAVITY AND INSTALLATION DIMENSIONS [mm]

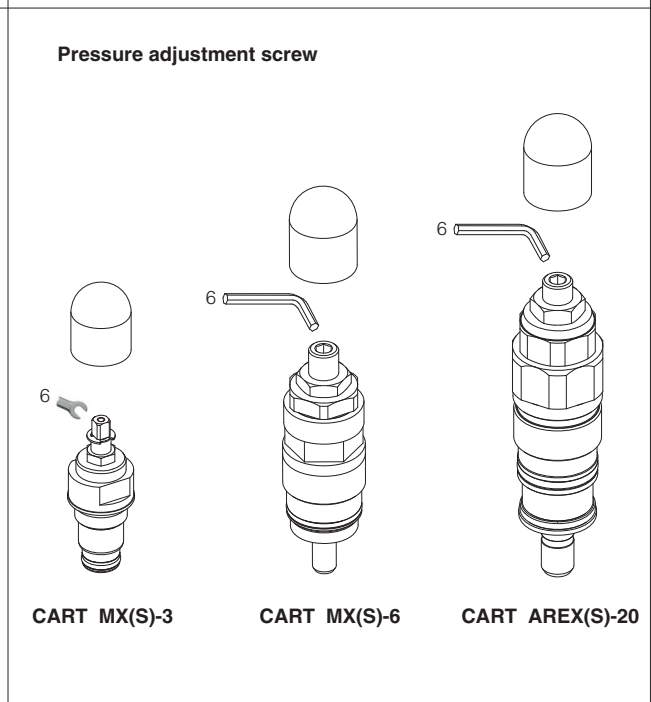
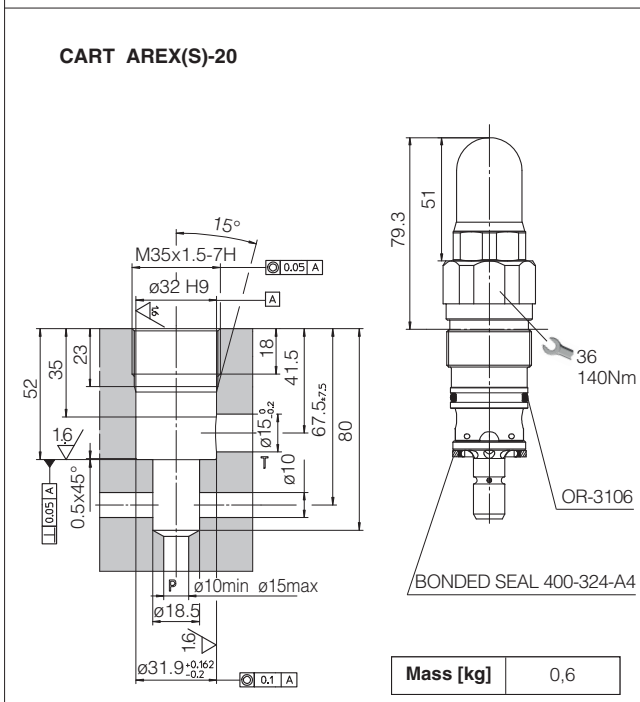
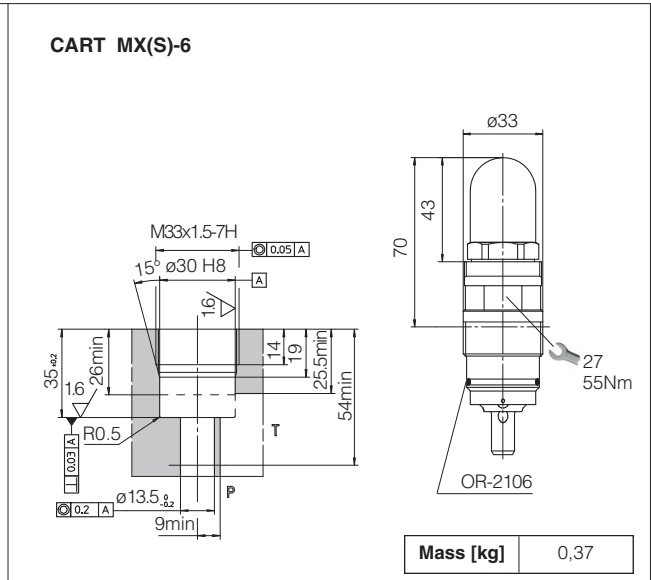
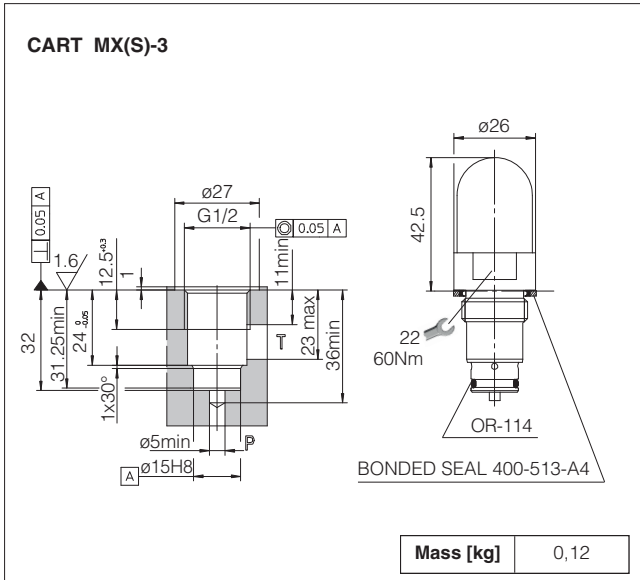

9 RELATED DOCUMENTATION

- W010** Basics for electrohydraulics in corrosive environments
- W020** Summary of Atos stainless steel components
- EW900** Operating and maintenance information for stainless steel on-off valves