

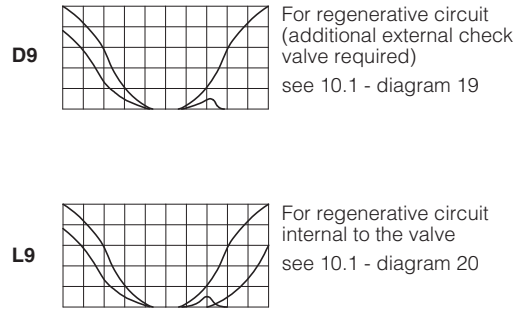

**2 SPOOLS SPECIFIC FOR REGENERATIVE CIRCUIT** - for valve model code and options, see section **1**

**DPZE** - **TID** - **NP** - **2** **71 - L9** / \* / \* \* / \*

**Configuration and spool:**

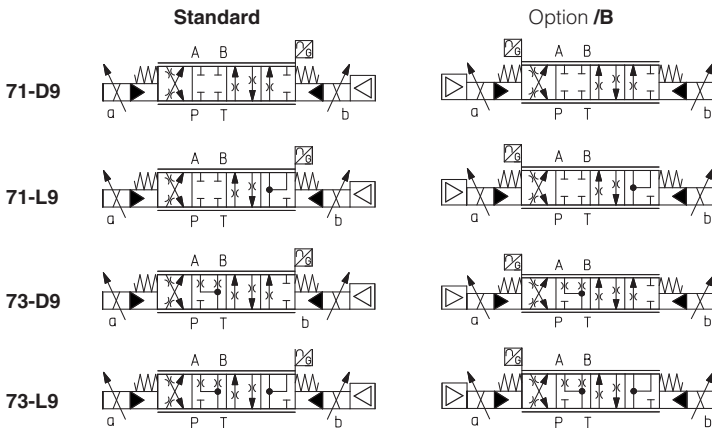

**Spool type and size: D9 L9**

DPZO-2	=	250	250
DPZO-4	=	480	-
DPZO-6	=	-	-

Nominal flow (l/min) at  $\Delta p$  10bar P-T

**3 GENERAL NOTES**

Atos digital proportionals valves are CE marked according to the applicable directives (e.g. Immunity and Emission EMC Directive). Installation, wirings and start-up procedures must be performed according to the general prescriptions shown in tech table **FS900** and in the user manuals included in the E-SW-SETUP programming software.

**4 VALVE SETTINGS AND PROGRAMMING TOOLS** - see tech. table **GS500**

**4.1 TID-NP**

**Atos CONNECT mobile App**

Free downloadable App for smartphones and tablets which allows quick access to valve main functional parameters and basic diagnostic information via Bluetooth, thus avoiding physical cable connection and significantly reducing commissioning time. Atos CONNECT supports Atos digital valve drivers equipped with E-A-BTH adapter or with built-in Bluetooth. It does not support valves with p/Q control or axis controls.



**E-SW-SETUP PC software**

Free downloadable software for PC allows to set all valve functional parameters and to access complete diagnostic information of digital valve drivers via Bluetooth/USB service port. Atos E-SW-SETUP PC software supports all Atos digital valve drivers and it is available at [www.atos.com](http://www.atos.com) in MyAtos area.



**WARNING: drivers USB port is not isolated!** For E-C-SB-USB/M12 cable, the use of E-A-SB-USB/OPT isolator is highly recommended for PC protection

**4.2 TID-BC**

**E-SW-SETUP PC software**

Free downloadable software for PC allows to set all valve functional parameters and to access complete diagnostic information of digital valve drivers via CANopen connector. Atos E-SW-SETUP PC software supports all Atos digital valve drivers and it is available at [www.atos.com](http://www.atos.com) in MyAtos area.

**Bluetooth or USB connection**

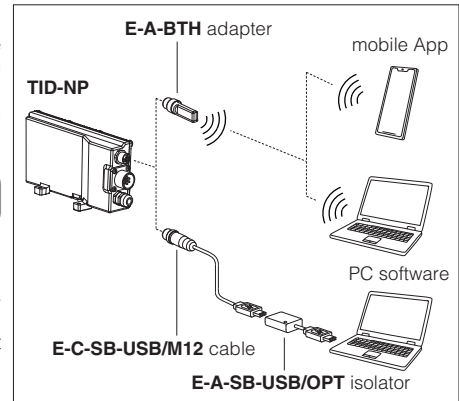

**CANopen connection**

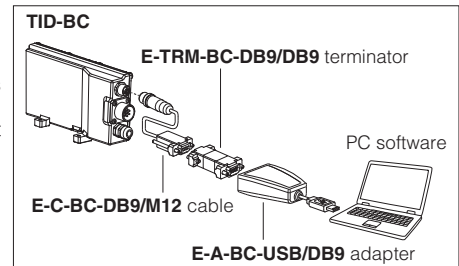

**5 BLUETOOTH OPTION** - only for TID-NP - see tech. table **GS500**

**T** option adds Bluetooth® connectivity to Atos valve drivers thanks to E-A-BTH adapter, which can be left permanently installed on-board, to allow the Bluetooth connection with the valve drivers at any time. E-A-BTH adapter can also be purchased separately and used to connect with any supported Atos digital product.

Bluetooth connection to the valve can be protected against unauthorised access by setting a personal password. The adapter leds visually indicates the status of valve driver and Bluetooth connection.



**WARNING:** for the list of countries where the Bluetooth adapter has been approved, see tech. table **GS500**  
**T** option is not available for the Indian market, so the Bluetooth adapter must be ordered separately.

## 6 GENERAL CHARACTERISTICS

Assembly position	Any position
Subplate surface finishing to ISO 4401	Acceptable roughness index: Ra ≤ 0,8, recommended Ra 0,4 – Flatness ratio 0,01/100
MTTFd valves according to EN ISO 13849	75 years, for further details see technical table P007
Ambient temperature range	<b>Standard</b> = -20°C ÷ +60°C <b>/PE option</b> = -20°C ÷ +60°C
Storage temperature range	<b>Standard</b> = -20°C ÷ +70°C <b>/PE option</b> = -20°C ÷ +70°C
Surface protection	Zinc coating with black passivation (body), tin plating (driver housing)
Corrosion resistance	Salt spray test (EN ISO 9227) > 200 h
Vibration resistance	See technical table G004
Conformity	CE according to EMC directive 2014/30/EU (Immunity: EN 61000-6-2; Emission: EN 61000-6-3) RoHS Directive 2011/65/EU as last update by 2015/863/EU REACH Regulation (EC) n°1907/2006

## 7 HYDRAULIC CHARACTERISTICS - based on mineral oil ISO VG 46 at 50 °C

Valve model	DPZE-*-2		DPZE-*-4	DPZE-*-6
Pressure limits [bar]	ports <b>P, A, B, X</b> = 350; <b>T</b> = 250 (10 for option /D); <b>Y</b> = 10;			
Spool type and size (1)	standard	<b>L3, S3, D3</b>	<b>L5, DL5, S5, D5</b>	<b>L5, S5, D5</b>
	regenerative		<b>D9, L9</b>	<b>D9</b>
Nominal flow Δp P-T (2)	Δp= 10 bar	160	250	480
	Δp= 30 bar	270	430	830
	Max permissible flow	400	550	1000
				1600
Piloting pressure [bar]	min. = 25; max = 350			
Piloting volume [cm³]	3,7		9,0	21,6
Piloting flow (3) [l/min]	3,7		6,8	14,4
Leakage (4)	Pilot [cm³]	100 / 300	200 / 500	900 / 2800
	Main stage [l/min]	0,2 / 0,6	0,3 / 1,0	1,0 / 3,0
Response time (5) [ms]	≤ 75		≤ 90	≤ 120
Hysteresis	≤ 1 [% of max regulation]			
Repeatability	± 0,5 [% of max regulation]			
Thermal drift	zero point displacement < 1% at ΔT = 40°C			

(1) For spool type **D** and **DL** the flow value is referred to single path P-A (A-T) at Δp/2 per control edge. The flow P-B (B-T) is 50% of P-A (A-T)

(2) For different Δp, the max flow is in accordance to the diagrams in section 10.2

(3) With step reference input signal 0 ÷ 100 %

(4) At p = 100/350 bar

(5) 0-100% step signal see detailed diagrams in section 10.3

## 8 ELECTRICAL CHARACTERISTICS

Power supplies	Nominal : +24 VDC Rectified and filtered : VRMS = 20 ÷ 32 VMAX (ripple max 10 % VPP)
Max power consumption	50 W
Max. solenoid current	2,6 A
Coil resistance R at 20°C	3,1 Ω
Analog input signals (1)	Voltage: range ±10 VDC (24 VMAX tolerant)     Input impedance: Ri > 50 kΩ Current: range ±20 mA     Input impedance: Ri = 500 Ω
Monitor outputs (1)	Output range: voltage ±10 VDC @ max 5 mA current ±20 mA @ max 500 Ω load resistance
Alarms	Solenoid not connected/short circuit, cable break with current reference signal (1), over/under temperature, valve spool transducer malfunctions, alarms history storage function
Insulation class	H (180°) Due to the occurring surface temperatures of the solenoid coils, the European standards ISO 13732-1 and EN982 must be taken into account
Protection degree to DIN EN60529	IP66 / IP67 with mating connectors
Duty factor	Continuous rating (ED=100%)
Additional characteristics	Short circuit protection of solenoid's current supply; spool position control by P.I.D. with rapid solenoid switching; protection against reverse polarity of power supply
Communication interface	USB - Atos ASCII coding     CANopen - EN50325-4 + DS408
Communication physical layer	not insulated - USB 2.0 + USB OTG     optical insulated - CAN ISO11898
Recommended wiring cable	LiYCY shielded cables, see section 16

(1) Available only for TID-NP

**Note:** a maximum time of 500 ms (depending on communication type) has to be considered between the driver energizing with the 24 Vdc power supply and when the valve is ready to operate. During this time the current to the valve coils is switched to zero.

**9 SEALS AND HYDRAULIC FLUIDS** - for other fluids not included in below table, consult our technical office

Seals, recommended fluid temperature	NBR seals (standard) = -20°C ÷ +60°C, with HFC hydraulic fluids = -20°C ÷ +50°C FKM seals (/PE option) = -20°C ÷ +80°C		
Recommended viscosity	20 ÷ 100 mm <sup>2</sup> /s - max allowed range 15 ÷ 380 mm <sup>2</sup> /s		
Max fluid contamination level	normal operation	ISO4406 class 18/16/13 NAS1638 class 7	see also filter section at www.atos.com or KTF catalog
	longer life	ISO4406 class 16/14/11 NAS1638 class 5	
<b>Hydraulic fluid</b>	<b>Suitable seals type</b>	<b>Classification</b>	<b>Ref. Standard</b>
Mineral oils	NBR, FKM	HL, HLP, HLPD, HVLP, HVLPD	DIN 51524
Flame resistant without water	FKM	HFDU, HFDR	ISO 12922
Flame resistant with water	NBR	HFC	

**10 DIAGRAMS** (based on mineral oil ISO VG 46 at 50 °C)

**10.1 Regulation diagrams** (values measure at p 10 bar P-T)

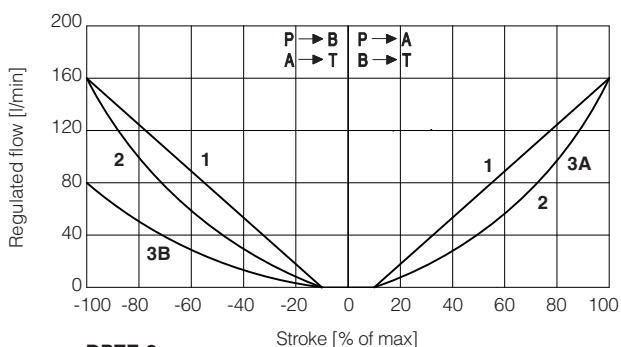

**DPZE-2:**  
**1** = L3    **3A** = D3 (P → A, A → T)  
**2** = S3    **3B** = D3 (P → B, B → T)

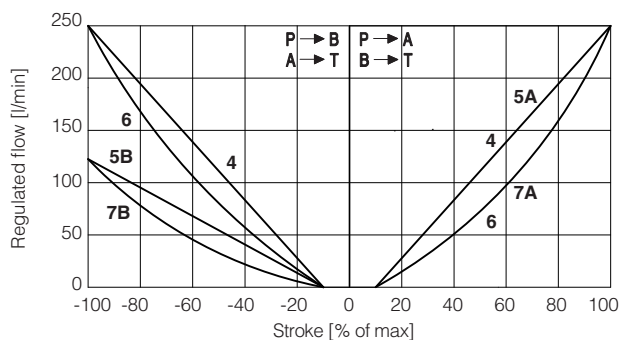

**DPZE-2:**  
**4** = L5    **5A** = DL5 (P → A, A → T)    **7A** = D5 (P → A, A → T)  
**6** = S5    **5B** = DL5 (P → B, B → T)    **7B** = D5 (P → B, B → T)

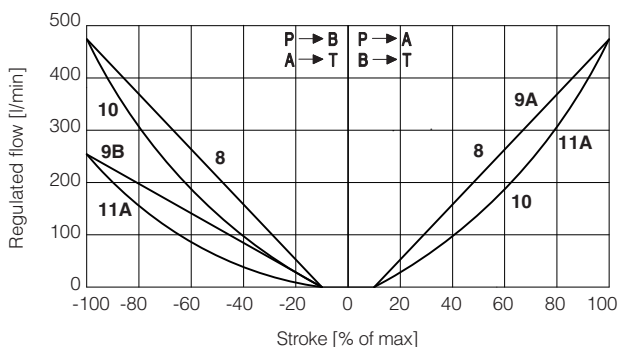

**DPZE-4:**  
**8** = L5    **9A** = DL5 (P → A, A → T)    **11A** = D5 (P → A, A → T)  
**10** = S5    **9B** = DL5 (P → B, B → T)    **11B** = D5 (P → B, B → T)

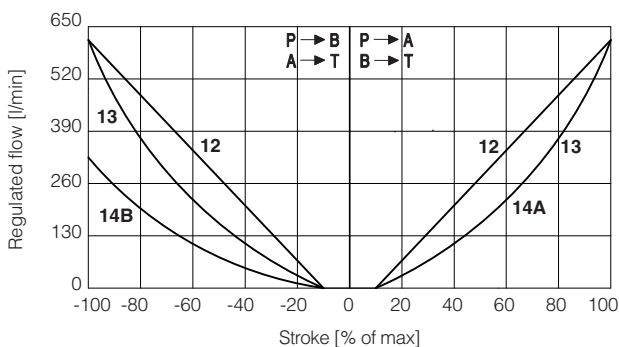

**DPZE-6:**  
**12** = L5    **14A** = D5 (P → A, A → T)  
**13** = S5    **14B** = D5 (P → B, B → T)

**Note:**

Hydraulic configuration vs. reference signal (standard and option /B)

**TID-NP**

Reference signal  $\left. \begin{matrix} 0 \div +10 \text{ V} \\ 12 \div 20 \text{ mA} \end{matrix} \right\} P \rightarrow A / B \rightarrow T$   
 Reference signal  $\left. \begin{matrix} 0 \div -10 \text{ V} \\ 12 \div 4 \text{ mA} \end{matrix} \right\} P \rightarrow B / A \rightarrow T$

**TID-BC**

Positive reference signal     $P \rightarrow A / B \rightarrow T$   
 Negative reference signal     $P \rightarrow B / A \rightarrow T$

**15** = differential - regenerative spool **D9**  
(not available for valve size 32)

D9 spool type with a fourth position specific to regenerative circuit, performed by means of an additional external check valve.

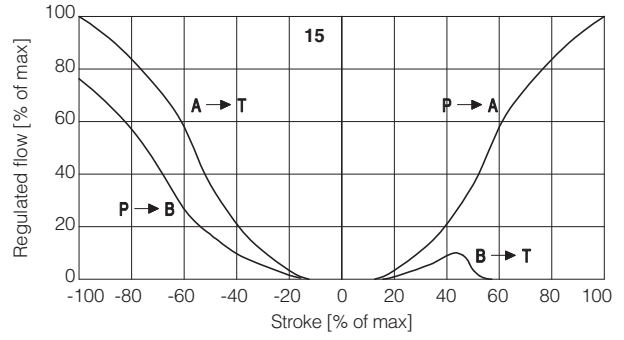
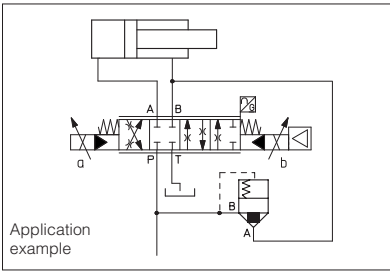

**16** = linear - internal regenerative spool **L9**  
(available only for valve size 16)

L9 spool type with a fourth position specific to perform a regenerative circuit internal to the valve.

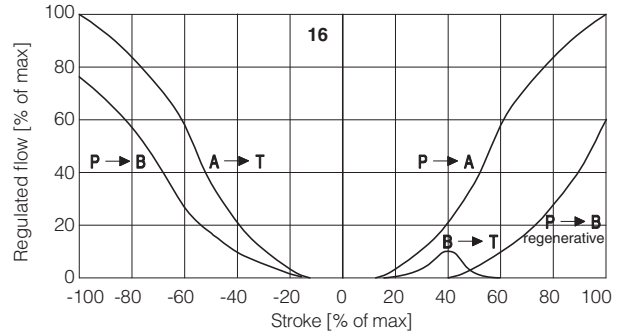

### 10.2 Operating diagrams

**Flow /  $\Delta p$  diagram** stated at 100% of spool stroke

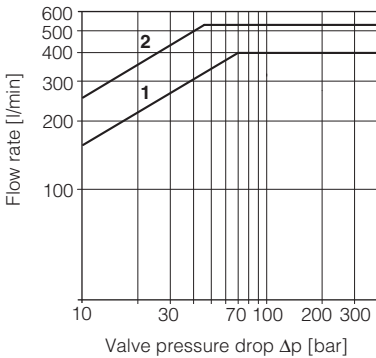

**DPZE-2:**

**1** = spools L3, S3, D3

**2** = spools L5, S5, D5, DL5, D9, L9

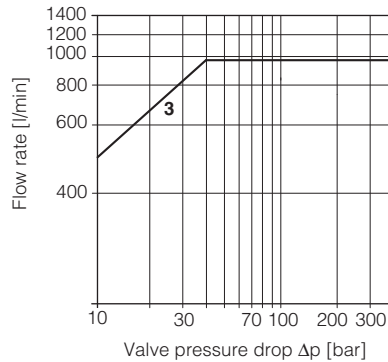

**DPZE-4:**

**3** = spools L5, S5, D5, DL5, D9

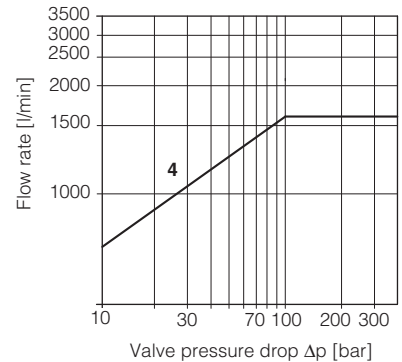

**DPZE-6:**

**4** = L5, S5, D5

### 10.3 Response time

The response times in below diagrams are measured at different steps of the reference input signal. They have to be considered as average values.

For the valves with digital electronics the dynamics performances can be optimized by setting the internal software parameters.

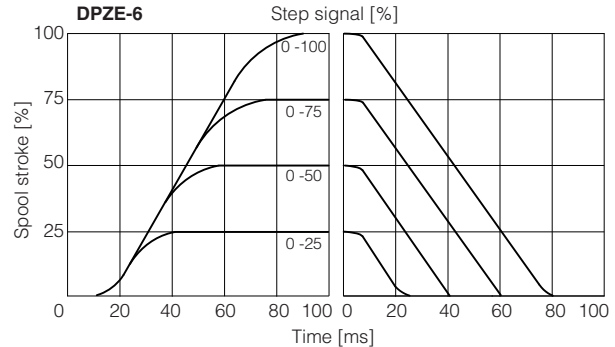
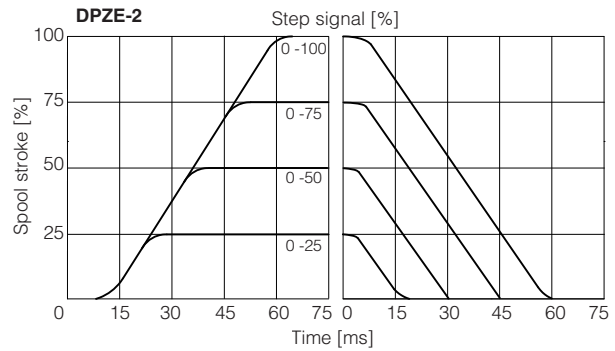
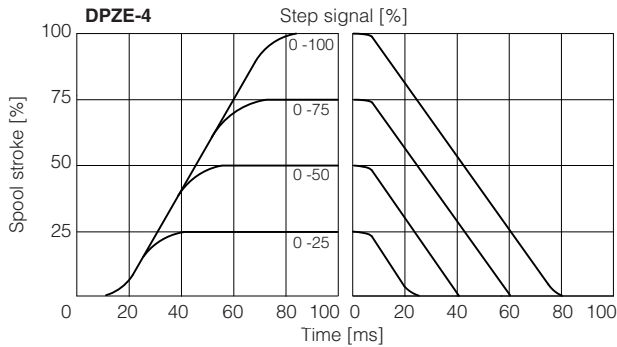

### 10.4 Configuration 72

Only for **DPZE** sizes **2** and **4** with spools **L5**, **S5** or **D5**: in central position the leakages P-A and P-B are drained to tank, avoiding the drift of cylinders with differential areas.

### 11 HYDRAULIC OPTIONS

**B** = Configurations 71, 73: on-board digital driver connectors and LVDT transducer at side of port A of the main stage (side B of pilot valve).  
For hydraulic configuration vs reference signal, see 9.1

**D** = Internal drain.  
Pilot and drain configuration can be modified as shown in section 17.  
The valve's standard configuration provides internal pilot and external drain.

**E** = External pilot (through port X).  
Pilot and drain configuration can be modified as shown in section 17.  
The valve's standard configuration provides internal pilot and external drain.

- ① Pilot valve
- ② Main stage
- ③ Pressure reducing valve
- ④ Plug to be added for external pilot trough port X
- ⑤ Plug to be removed for internal drain through port T

Functional Scheme - example of configuration 71

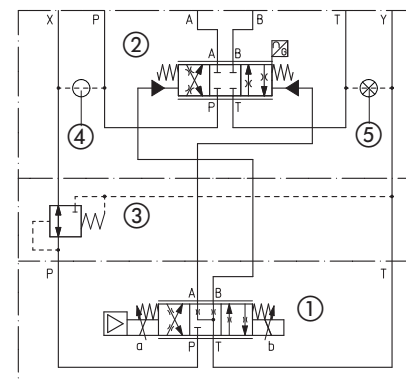

### 12 ELECTRONIC OPTIONS - only for TID-NP

**I** = This option provides 4 ÷ 20 mA current reference and monitor signals, instead of the standard ±10 VDC.  
It is normally used in case of long distance between the machine control unit and the valve or where the reference signal can be affected by electrical noise; the valve functioning is disabled in case of reference signal cable breakage.

**J** = This option provides 4 ÷ 20 mA current reference and ±10 VDC voltage monitor signals.  
The valve functioning is disabled in case of reference signal cable breakage.

### 13 POSSIBLE COMBINED OPTIONS

for **TID-NP**: /BD, /BE, /BI, /BJ, /BDE, /BDI, /BDJ, /BEI, /BEJ, /BDEI, /BDEJ, /DE, /DI, /DJ, /DEI, /DEJ, /EI, /EJ  
for **TID-BC**: /BD, /BE, /DE, BDE,

**Note:** /T Bluetooth adapter option can be combined with all other options

## 14 POWER SUPPLY AND SIGNALS SPECIFICATIONS

### 14.1 Power supply (V+ and V0)

The power supply must be appropriately stabilized or rectified and filtered: apply at least a 10000  $\mu$ F/40 V capacitance to single phase rectifiers or a 4700  $\mu$ F/40 V capacitance to three phase rectifiers.



A safety fuse is required in series to the power supply: 2,5 A time lag fuse.

### 14.2 Flow reference input signal (Q\_INPUT+) - only for TID-NP

The driver controls in closed loop the valve spool position proportionally to the external reference input signal.

*Standard (voltage reference input):* default is  $\pm 10$  Vdc and can be reconfigured via software, within a maximum range of  $\pm 10$  Vdc.

*Options /I and /J (current reference input):* default is  $4 \div 20$  mA and can be reconfigured via software, within a maximum range of  $\pm 20$  mA.

### 14.3 Flow monitor output signal (Q\_MONITOR) - only for TID-NP

The driver generates an analog output signal proportional to the actual spool position of the valve; the monitor output signal can be software set to show other signals available in the driver.

*Standard and option /J (voltage monitor output):* default is  $\pm 10$  Vdc and can be reconfigured via software, within a maximum range of  $\pm 10$  Vdc.

*Option /I (current monitor output):* default is  $4 \div 20$  mA and can be reconfigured via software, within a maximum range of  $\pm 20$  mA.

#### Note:

monitor output signal must not be directly used to activate safety functions, like to switch-ON/OFF the machine's safety components, as prescribed by the European standards (Safety requirements of fluid technology systems and components-hydraulics, ISO 4413).

## 15 ELECTRONIC CONNECTIONS

### 15.1 Main connector signals - 7 pin (A1) (A2)

PIN	TID-NP	TID-BC	TECHNICAL SPECIFICATIONS	NOTES
A	V+		Power supply 24 Vdc	Input - power supply
B	V0		Power supply 0 Vdc	Gnd - power supply
C	AGND	(1)	Analog ground	Gnd - analog signal
D	Q_INPUT+	(1)	Flow reference input signal: $\pm 10$ Vdc for standard, $4 \div 20$ mA for /I and /J options	Input - analog signal
E	INPUT-	(1)	Negative reference input signal for Q_INPUT+	Input - analog signal
F	Q_MONITOR	(1)	Flow monitor output signal: $\pm 10$ Vdc for standard and /J option, $4 \div 20$ mA for /I option, referred to AGND	Output - analog signal
G	EARTH		Internally connected to driver housing	

(1) Do not connect for TID-BC

### 15.2 USB connector - M12 5 pin (B) - only for TID-NP

PIN	SIGNAL	TECHNICAL SPECIFICATION (1)
1	+5V_USB	Power supply
2	ID	Identification
3	GND_USB	Signal zero data line
4	D-	Data line -
5	D+	Data line +

(1) Shield connection on connector housing is recommended

### 15.3 CANopen connector - M12 - 5 pin (C) - only for TID-BC

PIN	SIGNAL	TECHNICAL SPECIFICATION (1)
1	CAN_SHLD	Shield
2	not used	-
3	CAN_GND	Signal zero data line
4	CAN_H	Bus line (high)
5	CAN_L	Bus line (low)

(1) Shield connection on connector housing is recommended

## 15.4 Connections layout

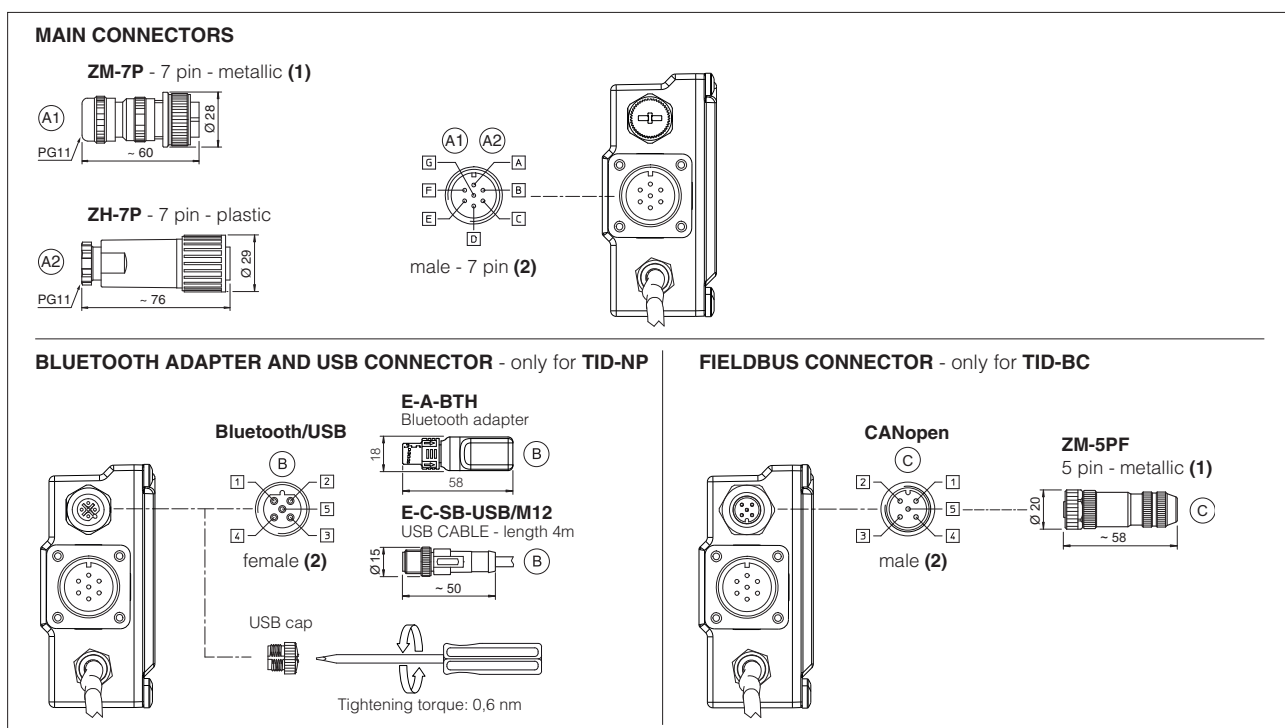

(1) use of metallic connectors is strongly recommended in order to fulfill EMC requirements

(2) pin layout always referred to driver's view

**16 CONNECTORS CHARACTERISTICS** - to be ordered separately

**16.1 Main connectors - 7 pin**

CONNECTOR TYPE	POWER SUPPLY	POWER SUPPLY
CODE	(A1) ZM-7P	(A2) ZH-7P
Type	7pin female straight circular	7pin female straight circular
Standard	According to MIL-C-5015	According to MIL-C-5015
Material	Metallic	Plastic reinforced with fiber glass
Cable gland	PG11	PG11
Recommended cable	LiYCY 7 x 0,75 mm <sup>2</sup> max 20 m (logic and power supply) or LiYCY 7 x 1 mm <sup>2</sup> max 40 m (logic and power supply)	LiYCY 7 x 0,75 mm <sup>2</sup> max 20 m (logic and power supply) or LiYCY 7 x 1 mm <sup>2</sup> max 40 m (logic and power supply)
Conductor size	up to 1 mm <sup>2</sup> - available for 7 wires	up to 1 mm <sup>2</sup> - available for 7 wires
Connection type	to solder	to solder
Protection (EN 60529)	IP 67	IP 67

**16.2 Fieldbus communication connector - only for TID-BC**

CONNECTOR TYPE	CANopen
CODE	(C) ZM-5PF
Type	5 pin female straight circular
Standard	M12 coding A – IEC 61076-2-101
Material	Metallic
Cable gland	Pressure nut - cable diameter 6÷8 mm
Cable	CANbus Standard (DR 303-1)
Connection type	screw terminal
Protection (EN 60529)	IP67

**17 PLUGS LOCATION FOR PILOT/DRAIN CHANNELS**

Depending on the position of internal plugs, different pilot/drain configurations can be obtained as shown below. To modify the pilot/drain configuration, proper plugs must only be interchanged. The plugs have to be sealed using loctite 270. Standard valves configuration provides internal pilot and external drain

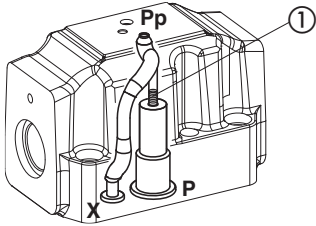
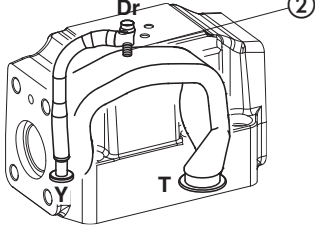
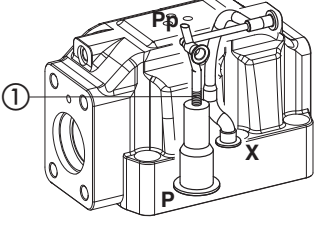
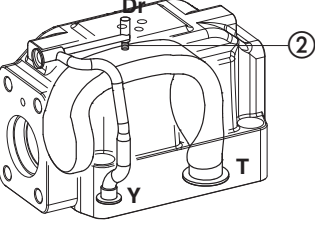
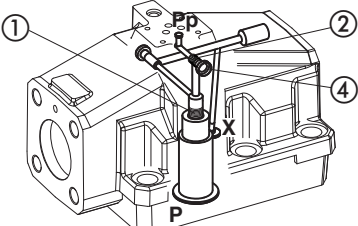
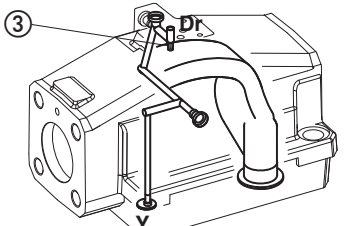
<p><b>DPZE-2 Pilot channels</b></p> 	<p><b>Drain channels</b></p> 	<p><b>Internal piloting:</b> Without blinded plug SP-X300F ①;  <b>External piloting:</b> Add blinded plug SP-X300F ①;  <b>Internal drain:</b> Without blinded plug SP-X300F ②;  <b>External drain:</b> Add blinded plug SP-X300F ②.</p>
<p><b>DPZE-4 Pilot channels</b></p> 	<p><b>Drain channels</b></p> 	<p><b>Internal piloting:</b> Without blinded plug SP-X500F ①;  <b>External piloting:</b> Add blinded plug SP-X500F ①;  <b>Internal drain:</b> Without blinded plug SP-X300F ②;  <b>External drain:</b> Add blinded plug SP-X300F ②.</p>
<p><b>DPZE-6 Pilot channels</b></p> 	<p><b>Drain channels</b></p> 	<p><b>Internal piloting:</b> Without plug ①;  <b>External piloting:</b> Add DIN-908 M16x1,5 in pos ①;  <b>Internal drain:</b> Without blinded plug SP-X300F ③;  <b>External drain:</b> Add blinded plug SP-X300F ③.</p>

### DPZE-TID-\*<sup>-</sup>2

ISO 4401: 2005  
 Mounting surface: 4401-07-07-0-05  
 (see table P005)

DPZE-* <sup>-</sup> 2	Mass [kg]
all versions	14,8

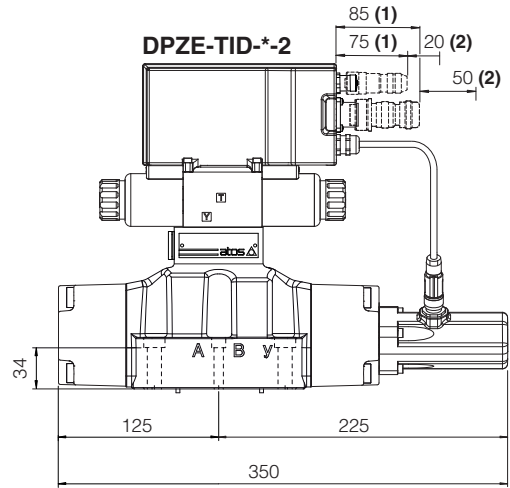
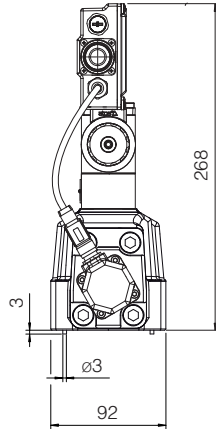

- (1) The indicated dimension refers to the longer connectors or Bluetooth adapter  
 For dimensions of connectors and Bluetooth adapter, see section 15.4
- (2) Space required for connection cable and for connector removal

### DPZE-TID-\*<sup>-</sup>2 / B

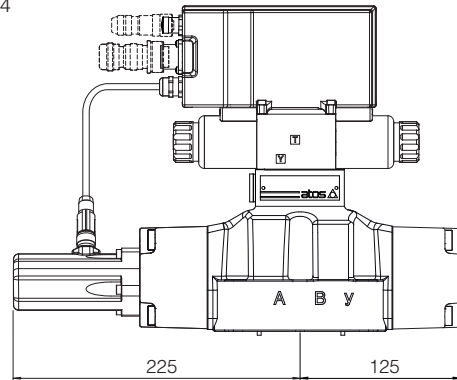

### DPZE-TID-\*<sup>-</sup>4

ISO 4401: 2005  
 Mounting surface: 4401-08-08-0-05  
 (see table P005)

DPZE-* <sup>-</sup> 4	Mass [kg]
all versions	19,3

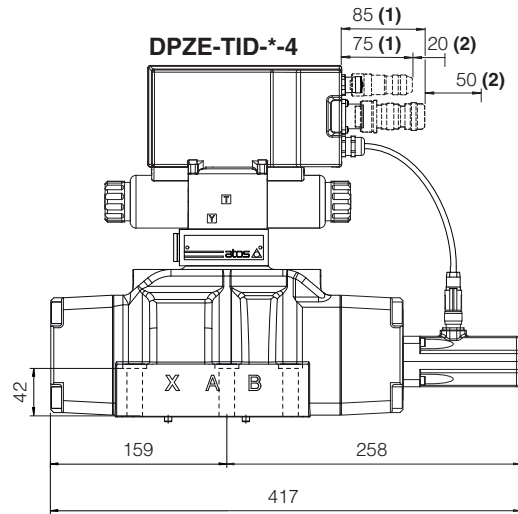
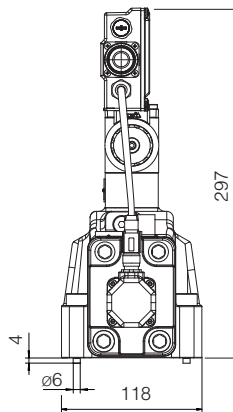

- (1) The indicated dimension refers to the longer connectors or Bluetooth adapter  
 For dimensions of connectors and Bluetooth adapter, see section 15.4
- (2) Space required for connection cable and for connector removal

### DPZE-TID-\*<sup>-</sup>4 / B

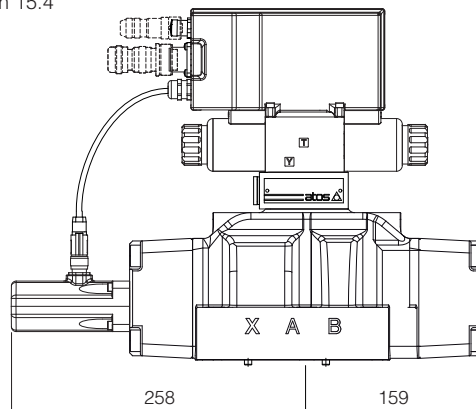

## DPZE-TID-\*<sup>-6</sup>

ISO 4401: 2005

Mounting surface: 4401-10-09-0-05  
(see table P005)

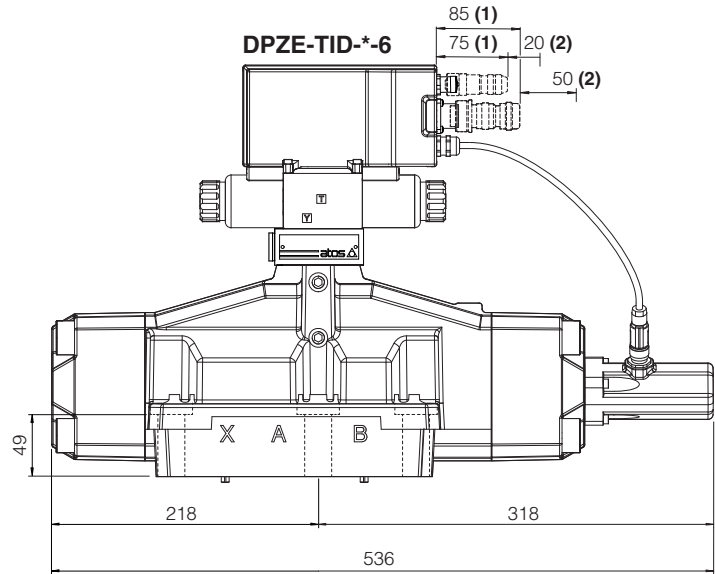
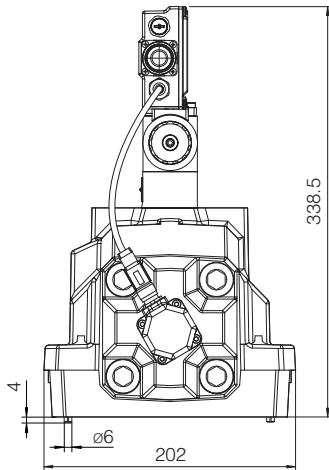

DPZE-* <sup>-6</sup>	Mass [kg]
all versions	43,3

- (1) The indicated dimension refers to the longer connectors or Bluetooth adapter  
For dimensions of connectors and Bluetooth adapter, see section 15.4
- (2) Space required for connection cable and for connector removal

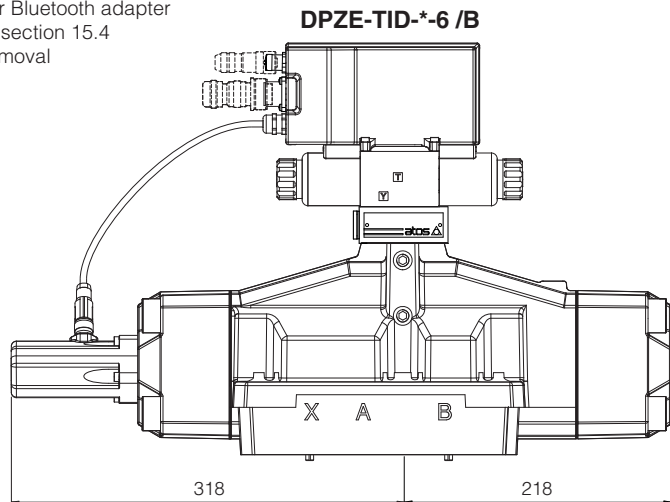

### 19 FASTENING BOLTS AND SEALS

Type	Size	Fastening bolts	Seals
DPZE	2 = 16	4 socket head screws M10x50 class 12.9 Tightening torque = 70 Nm 2 socket head screws M6x45 class 12.9 Tightening torque = 15 Nm	4 OR 130; Diameter of ports A, B, P, T: $\varnothing$ 20 mm (max) 2 OR 2043 Diameter of ports X, Y: $\varnothing$ = 7 mm (max)
	4 = 25	6 socket head screws M12x60 class 12.9 Tightening torque = 125 Nm	4 OR 4112; Diameter of ports A, B, P, T: $\varnothing$ 24 mm (max) 2 OR 3056 Diameter of ports X, Y: $\varnothing$ = 7 mm (max)
	6 = 32	6 socket head screws M20x80 class 12.9 Tightening torque = 600 Nm	4 OR 144; Diameter of ports A, B, P, T: $\varnothing$ 34 mm (max) 2 OR 3056 Diameter of ports X, Y: $\varnothing$ = 7 mm (max)

### 20 RELATED DOCUMENTATION

<b>FS001</b>	Basics for digital electrohydraulics	<b>K800</b>	Electric and electronic connectors
<b>FS900</b>	Operating and maintenance information for proportional valves	<b>P005</b>	Mounting surfaces for electrohydraulic valves
<b>GS500</b>	Programming tools	<b>QB330</b>	Quickstart for TID-NP valves commissioning
<b>GS510</b>	Fieldbus	<b>QF330</b>	Quickstart for TID-BC valves commissioning
		<b>E-MAN-RI-TID</b>	TID user manual