

# Digital proportional directional valves

direct, without transducer, with positive spool overlap

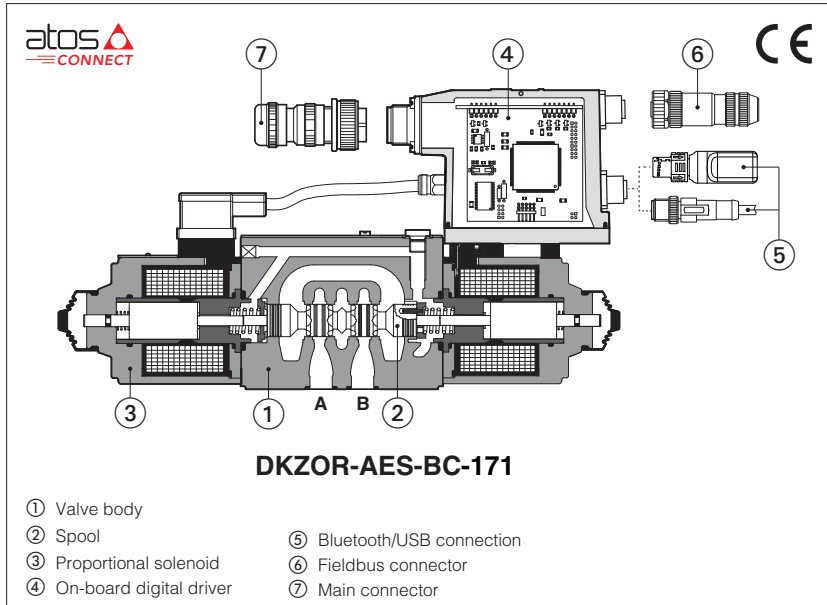

## DHZO-A, DHZO-AEB, DHZO-AES DKZOR-A, DKZOR-AEB, DKZOR-AES

Digital proportional valves without position transducer and with positive spool overlap, for open loop directional controls and not compensated flow regulations.

**A** to be coupled with off-board drivers.

**AEB** basic execution, with on-board digital driver, with analog reference signal or IO-Link interface for digital reference signal, valve settings, and real-time diagnostics.

**AES** full execution, with on-board digital driver which includes also fieldbus interfaces for digital reference signal, valve settings, and real-time diagnostics.

For **AEB** and **AES**, Bluetooth/USB connection is always present for valve settings via mobile App and Atos PC software.

<b>DHZO:</b>	<b>DKZOR:</b>
Size: <b>06</b> - ISO 4401	Size: <b>10</b> - ISO 4401
Max flow: <b>70 l/min</b>	Max flow: <b>160 l/min</b>
Max pressure: <b>350 bar</b>	Max pressure: <b>315 bar</b>

### 1 MODEL CODE for STANDARD SPOOLS

<b>DHZO</b>	-	<b>AES</b>	-	<b>BP</b>	-	<b>0</b>	<b>71</b>	-	<b>L</b>	<b>5</b>	/	*	/	*	/	*	/	*	/	*
<b>DHZO</b> = size 06 <b>DKZOR</b> = size 10																		<b>Seals material,</b> see section [11]: - = NBR <b>PE</b> = FKM <b>BT</b> = NBR low temp.		
<b>A</b> = off-board driver, see section [2] <b>AEB</b> = basic on-board digital driver <b>AES</b> = full on-board digital driver																		<b>Coil voltage,</b> only for <b>A</b> - see section [16]: - = standard coil for 24 Vdc Atos drivers <b>6</b> = optional coil for 12 Vdc Atos drivers <b>18</b> = optional coil for low current drivers		
<b>IO-Link interface,</b> only for <b>AEB</b> , see section [6]: <b>NP</b> = Not present <b>IL</b> = IO-Link																		<b>Bluetooth option,</b> only for <b>AEB</b> and <b>AES</b> , see section [5]: <b>T</b> = Bluetooth adapter supplied with the valve		
<b>Fieldbus interfaces,</b> only for <b>AES</b> , see section [7]: <b>BC</b> = CANopen <b>EH</b> = EtherCAT <b>BP</b> = PROFIBUS DP																				
<b>Valve size ISO 4401:</b> <b>0</b> = 06 <b>1</b> = 10																				

### Configuration (1):

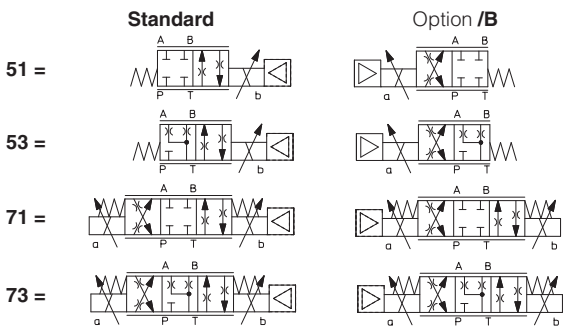

### Spool type, regulating characteristics, see section [12]:

<b>L</b> = linear	<b>S</b> = progressive	<b>D</b> = differential-progressive
P-A = Q, B-T = Q/2		
P-B = Q/2, A-T = Q		

### Hydraulic options (2):

**B** = solenoid and on-board digital driver at side of port A  
**Y** = external drain

### Hand lever options, only for A:

**MO** = horizontal hand lever  
**MV** = vertical hand lever  
**BMO** = horizontal hand lever installed at side of port A  
**BMV** = vertical hand lever installed at side of port A

### Electronic options (2), only for AEB-NP and AES:

**I** = current reference input 4 ÷ 20 mA  
**Q** = enable signal  
**Z** = double power supply, enable, fault and monitor signals - 12 pin connector

<b>Spool size:</b>	<b>14</b> (L)	<b>1</b> (L)	<b>2</b> (S)	<b>3</b> (L,S,D)	<b>5</b> (L,S,D)
DHZO =	1	4,5	8	18	28
DKZOR =	-	-	-	45	60

Nominal flow (l/min) at Δp 10bar P-T (see section [9])

(1) Hydraulic symbols are represented with on-board digital driver

(2) For possible combined options, see section [15]

**2 OFF-BOARD ELECTRONIC DRIVERS** - only for **A**

Drivers model	E-MI-AC-01F		E-MI-AS-IR		E-BM-AS-PS		E-BM-AES
Type	Analog				Digital		
Voltage supply (VDC)	12	24	12	24	12	24	24
Valve coil option	/6	std	/6	std	/6	std	std
Format	plug-in to solenoid				DIN-rail panel		
Tech table	G010		G020		G030		GS050

**3 GENERAL NOTES**

Atos digital proportionals valves are CE marked according to the applicable directives (e.g. Immunity and Emission EMC Directive). Installation, wirings and start-up procedures must be performed according to the general prescriptions shown in tech table **FS900** and in the user manuals included in the E-SW-SETUP programming software.

**4 VALVE SETTINGS AND PROGRAMMING TOOLS** - see tech. table **GS500**

**4.1 Atos CONNECT mobile App**

Free downloadable App for smartphones and tablets which allows quick access to valve main functional parameters and basic diagnostic information via Bluetooth, thus avoiding physical cable connection and significantly reducing commissioning time. Atos CONNECT supports Atos digital valve drivers equipped with E-A-BTH adapter or with built-in Bluetooth. It does not support valves with p/Q control or axis controls.



**4.2 E-SW-SETUP PC software**

Free downloadable software for PC allows to set all valve functional parameters and to access complete diagnostic information of digital valve drivers via Bluetooth/USB service port. Atos E-SW-SETUP PC software supports all Atos digital valve drivers and it is available at [www.atos.com](http://www.atos.com) in MyAtos area.



**WARNING: drivers USB port is not isolated!** For E-C-SB-USB/M12 cable, the use of E-A-SB-USB/OPT isolator adapter is highly recommended for PC protection

**Bluetooth or USB connection**

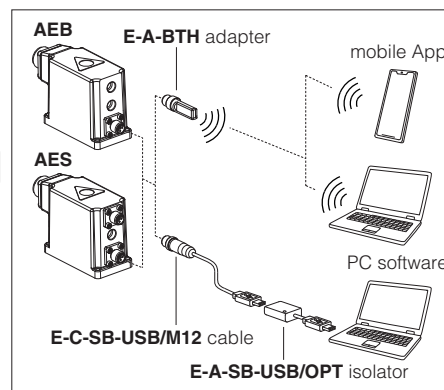

**5 BLUETOOTH OPTION** - see tech. table **GS500**

T option adds Bluetooth® connectivity to Atos valve drivers thanks to E-A-BTH adapter, which can be left permanently installed on-board, to allow the Bluetooth connection with the valve drivers at any time. E-A-BTH adapter can also be purchased separately and used to connect with any supported Atos digital product. Bluetooth connection to the valve can be protected against unauthorised access by setting a personal password. The adapter leds visually indicates the status of valve driver and Bluetooth connection.



**WARNING:** for the list of countries where the Bluetooth adapter has been approved, see tech. table **GS500**  
T option is not available for the Indian market, so the Bluetooth adapter must be ordered separately.

**6 IO-LINK** - only for **AEB**, see tech. table **GS520**

IO-Link allows low cost digital communication between the valve and machine central unit. The valve is directly connected to a port of an IO-Link master (point-to-point connection) via low-cost unshielded cables for digital reference, diagnostic and settings. The IO-Link master works as a hub exchanging this information with the machine central unit via fieldbus.

**7 FIELDBUS** - only for **AES**, see tech. table **GS510**

Fieldbus allows valve direct communication with machine control unit for digital reference, valve diagnostics and settings. These execution allow to operate the valves through fieldbus or analog signals available on the main connector.

**8 GENERAL CHARACTERISTICS**

Assembly position	Any position
Subplate surface finishing to ISO 4401	Acceptable roughness index: Ra ≤ 0,8, recommended Ra 0,4 – Flatness ratio 0,01/100
MTTFd valves according to EN ISO 13849	150 years, for further details see technical table P007
Ambient temperature range	<b>A:</b> Standard = -20°C ÷ +70°C /PE option = -20°C ÷ +70°C /BT option = -40°C ÷ +60°C <b>AEB, AES:</b> Standard = -20°C ÷ +60°C /PE option = -20°C ÷ +60°C /BT option = -40°C ÷ +60°C
Storage temperature range	<b>A:</b> Standard = -20°C ÷ +80°C /PE option = -20°C ÷ +80°C /BT option = -40°C ÷ +70°C <b>AEB, AES:</b> Standard = -20°C ÷ +70°C /PE option = -20°C ÷ +70°C /BT option = -40°C ÷ +70°C
Surface protection	Zinc coating with black passivation, galvanic treatment (driver housing for AEB and AES)
Corrosion resistance	Salt spray test (EN ISO 9227) > 200 h
Vibration resistance	See technical table G004 (for AEB and AES)
Compliance	CE according to EMC directive 2014/30/EU (Immunity: EN 61000-6-2; Emission: EN 61000-6-3) RoHS Directive 2011/65/EU as last update by 2015/863/EU REACH Regulation (EC) n°1907/2006

**9 HYDRAULIC CHARACTERISTICS** - based on mineral oil ISO VG 46 at 50 °C

Valve model	DHZO					DKZOR	
Pressure limits [bar]	ports <b>P, A, B</b> = 350; <b>T</b> = 210 (250 with external drain /Y) <b>Y</b> = 10					ports <b>P, A, B</b> = 315; <b>T</b> = 210 (250 with external drain /Y) <b>Y</b> = 10	
Spool type and size	<b>L14</b>	<b>L1</b>	<b>S2</b>	<b>L3, S3, D3</b>	<b>L5, S5, D5</b>	<b>L3, S3, D3</b>	<b>L5, S5, D5</b>
Nominal flow $\Delta p$ P-T [l/min]							
(1) $\Delta p = 10$ bar	1	4,5	8	18	28	45	60
$\Delta p = 30$ bar	1,7	8	14	30	50	80	105
$\Delta p = 70$ bar	2,6	12	21	45	70	120	160
Max permissible flow (2)	4	18	30	50	70	120	160
Leakage [cm <sup>3</sup> /min]	<30 (at p = 100 bar); <135 (at p = 350 bar)					<80 (at p = 100 bar); <600 (at p = 315 bar)	
Response time (3) [ms]	≤ 30					≤ 40	
Hysteresis	≤ 5 [% of max regulation]						
Repeatability	± 1 [% of max regulation]						

**Note:** above performance data refer to valves coupled with Atos electronic drivers, see section 2

(1) For different  $\Delta p$ , the max flow is in accordance to the diagrams in section 12.2

(2) See detailed diagrams in section 12.3

(3) 0-100% step signal, see detailed diagrams in section 12.4

**10 ELECTRICAL CHARACTERISTICS**

Power supplies	Nominal : +24 VDC Rectified and filtered : $V_{RMS} = 20 \div 32 V_{MAX}$ (ripple max 10 % VPP)					
Max power consumption	DHZO			DKZOR		
	<b>A</b> = 30 W	<b>AEB, AES</b> = 50 W		<b>A</b> = 35 W	<b>AEB, AES</b> = 50 W	
Coil voltage code	standard	option /6	option /18	standard	option /6	option /18
Max. solenoid current	2,2 A	2,75 A	1 A	2,6 A	3,25 A	1,2 A
Coil resistance R at 20°C	3 $\div$ 3,3 $\Omega$	2 $\div$ 2,2 $\Omega$	13 $\div$ 13,4 $\Omega$	3,8 $\div$ 4,1 $\Omega$	2,2 $\div$ 2,4 $\Omega$	12 $\div$ 12,5 $\Omega$
Analog input signals	Voltage: range $\pm 10$ VDC (24 VMAX tolerant) Current: range $\pm 20$ mA			Input impedance: $R_i > 50$ k $\Omega$ Input impedance: $R_i = 500$ $\Omega$		
Monitor output	Output range: voltage $\pm 5$ VDC @ max 5 mA					
Enable input	Range: 0 $\div$ 9 VDC (OFF state), 15 $\div$ 24 VDC (ON state), 9 $\div$ 15 VDC (not accepted); Input impedance: $R_i > 87$ k $\Omega$					
Fault output	Output range: 0 $\div$ 24 VDC (ON state $\equiv$ VL+ [logic power supply] ; OFF state $\equiv$ 0 V) @ max 50 mA; external negative voltage not allowed (e.g. due to inductive loads)					
Alarms	Solenoid not connected/short circuit, cable break with current reference signal, over/under temperature, current control monitoring, power supplies level					
Insulation class	H (180°) Due to the occurring surface temperatures of the solenoid coils, the European standards ISO 13732-1 and EN982 must be taken into account					
Protection degree to DIN EN60529	<b>A</b> = IP65; <b>AEB, AES</b> = IP66 / IP67 with mating connectors					
Duty factor	Continuous rating (ED=100%)					
Tropicalization	Tropical coating on electronics PCB					
Additional characteristics	Short circuit protection of solenoid's current supply; current control by P.I.D. with rapid solenoid switching; protection against reverse polarity of power supply					
Communication interface	USB	IO-Link	CANopen	PROFIBUS DP	EtherCAT	
	Atos ASCII coding	Interface and System Specification 1.1.3	EN50325-4 + DS408	EN50170-2/IEC61158	IEC 61158	
Communication physical layer	not insulated USB 2.0+USB OTG	SDCI class port B	optical insulated CAN ISO11898	optical insulated RS485	Fast Ethernet, insulated 100 Base TX	
Recommended wiring cable	LiYCY shielded cables, see section 20					

**Note:** a maximum time of 500 ms (depending on communication type) has to be considered between the driver energizing with the 24 Vdc power supply and when the valve is ready to operate. During this time the current to the valve coils is switched to zero.

**11 SEALS AND HYDRAULIC FLUIDS** - for other fluids not included in below table, consult our technical office

Seals, recommended fluid temperature	NBR seals (standard) = -20°C $\div$ +60°C (+80°C for <b>A</b> ), with HFC hydraulic fluids = -20°C $\div$ +50°C FKM seals (/PE option) = -20°C $\div$ +80°C NBR low temp. seals (/BT option) = -40°C $\div$ +60°C, with HFC hydraulic fluids = -20°C $\div$ +50°C		
Recommended viscosity	20 $\div$ 100 mm <sup>2</sup> /s - max allowed range 15 $\div$ 380 mm <sup>2</sup> /s		
Max fluid contamination level	normal operation	ISO4406 class 18/16/13 NAS1638 class 7	
	longer life	ISO4406 class 16/14/11 NAS1638 class 5	
		see also filter section at <a href="http://www.atos.com">www.atos.com</a> or KTF catalog	
<b>Hydraulic fluid</b>	<b>Suitable seals type</b>	<b>Classification</b>	<b>Ref. Standard</b>
Mineral oils	NBR, FKM, NBR low temp.	HL, HLP, HLPD, HVLP, HVLPD	DIN 51524
Flame resistant without water	FKM	HF DU, HF DR	ISO 12922
Flame resistant with water	NBR, NBR low temp.	HFC	

**12** **DIAGRAMS** - based on mineral oil ISO VG 46 at 50 °C

**12.1 Regulation diagrams** - values measure at  $\Delta p$  30 bar P-T

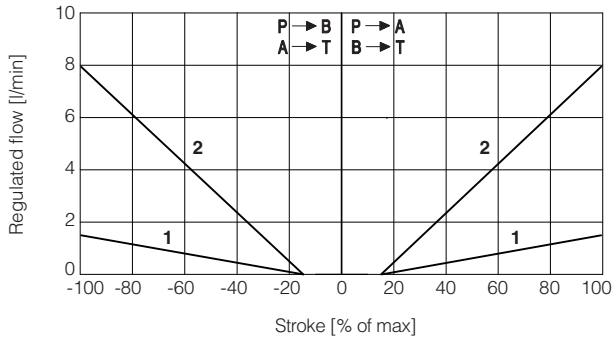

**DHZO**  
1 = L14    2 = L1

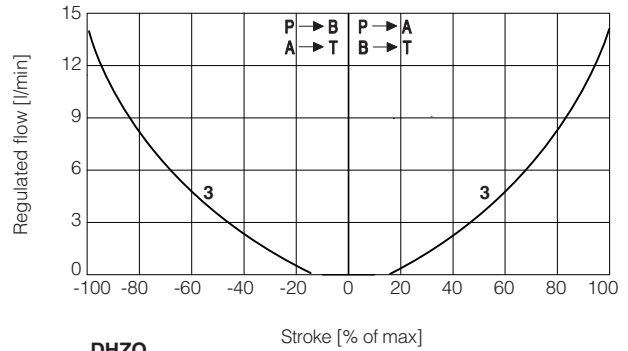

**DHZO**  
3 = S2

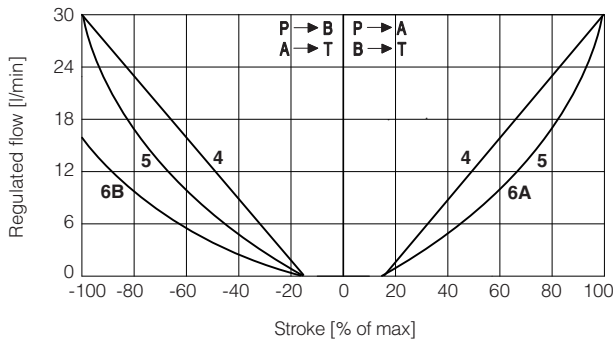

**DHZO**  
4 = L3    5 = S3    6A = D3 (P → A, A → T)  
6B = D3 (P → B, B → T)

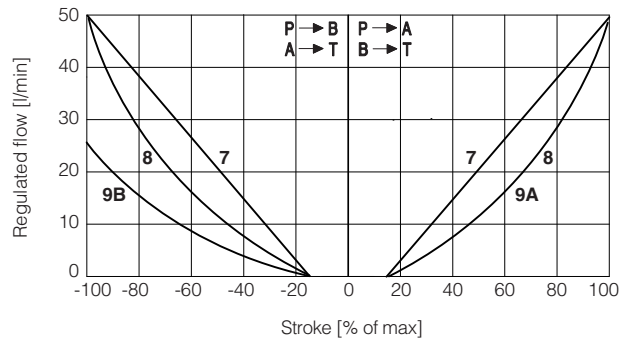

**DHZO**  
7 = L5    8 = S5    9A = D5 (P → A, A → T)  
9B = D5 (P → B, B → T)

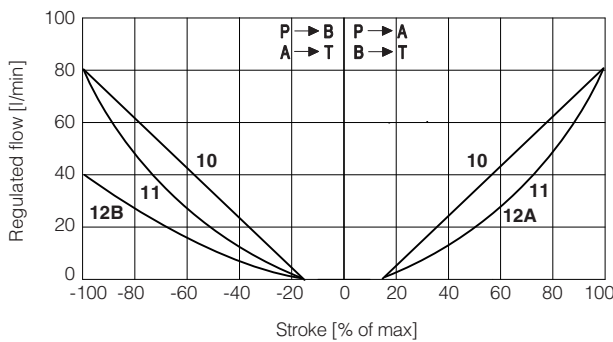

**DKZOR**  
10 = L3    11 = S3    12A = D3 (P → A, A → T)  
12B = D3 (P → B, B → T)

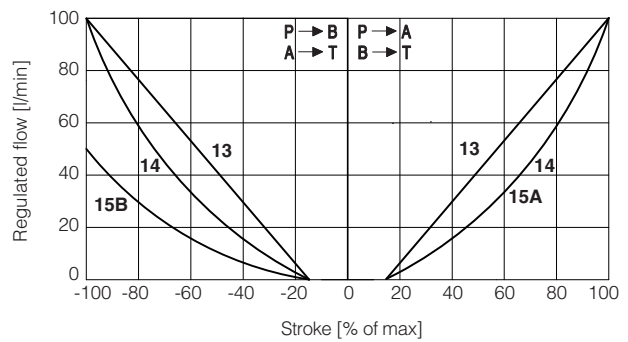

**DKZOR**  
13 = L5    14 = S5    15A = D5 (P → A, A → T)  
15B = D5 (P → B, B → T)

**Note:** Hydraulic configuration vs. reference signal for configuration 71 and 73 (standard and option /B)

Reference signal  $\left. \begin{matrix} 0 \div +10 \text{ V} \\ 12 \div 20 \text{ mA} \end{matrix} \right\} P \rightarrow A / B \rightarrow T$

Reference signal  $\left. \begin{matrix} 0 \div -10 \text{ V} \\ 12 \div 4 \text{ mA} \end{matrix} \right\} P \rightarrow B / A \rightarrow T$

**12.2 Flow / $\Delta p$  diagrams** - stated at 100% of valve stroke

**DHZO**

- 1 = spool L14
- 2 = spool L1
- 3 = spool S2
- 4 = spool L3, S3, D3
- 5 = spool L5, S5, D5

**DKZOR**

- 6 = spool S3, L3, D3
- 7 = spool S5, L5, D5

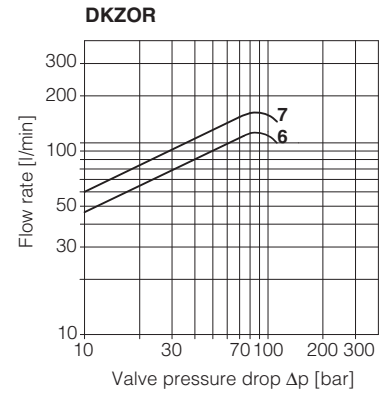
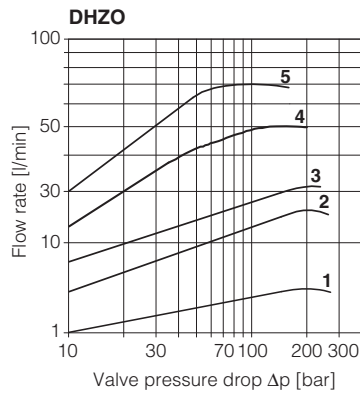

**12.3 Operating limits**

**DHZO**

- 1 = spool L14
- 2 = spool L1
- 3 = spool S2
- 4 = spool L3, S3, D3
- 5 = spool L5, S5, D5

**DKZOR**

- 6 = spool S3, L3, D3
- 7 = spool S5, L5, D5

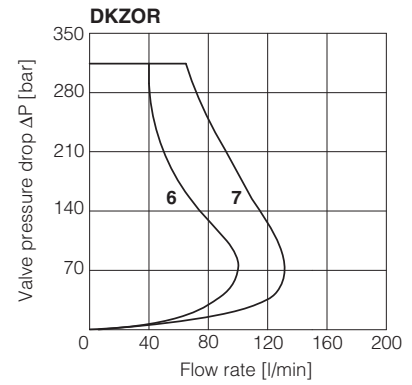
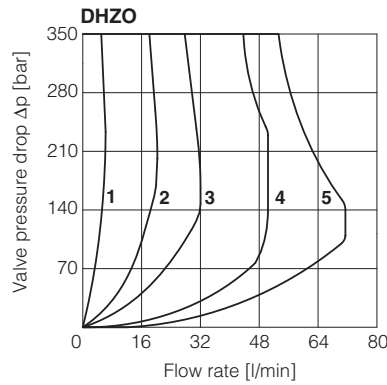

**12.4 Response time**

The response times in below diagrams are measured at different steps of the reference input signal. They have to be considered as average values. For the valves with digital electronics the dynamics performances can be optimized by setting the internal software parameters.

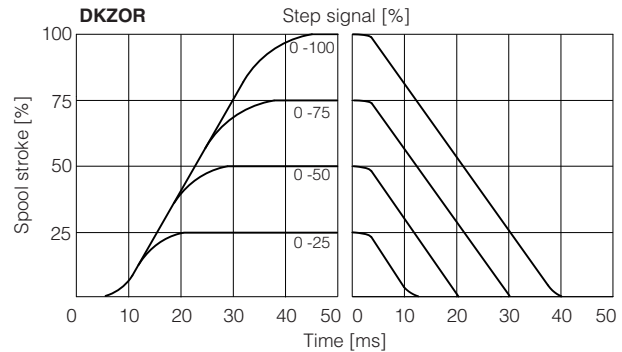
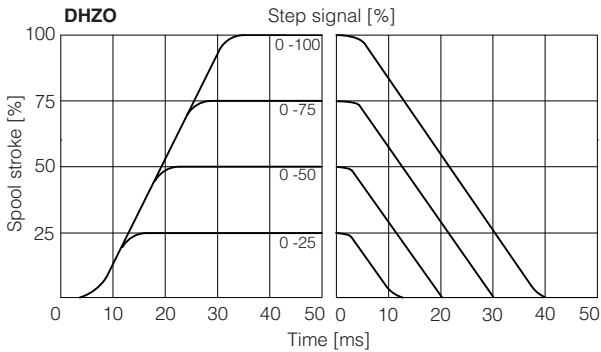

**12.5 Operation as throttle valve**

Single solenoid valves configuration 51 and 53 can be used as simple throttle valves:  
 $P_{max} = 250$  bar (option *Y* advisable)

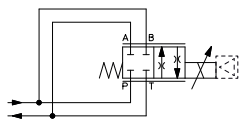

Max flow $\Delta p = 15$ bar [l/min]	Spool type and size				
	L14	L1	S2	L3 S3	L5 S5
<b>DHZO</b>	4	16	28	60	100
<b>DKZOR</b>	-	-	-	160	200

### 13 HYDRAULIC OPTIONS

- B** = DHZO-05 and DKZOR-15 = solenoid and on-board digital driver at side of port A.  
DHZO-07 and DKZOR-17 = on-board digital driver at side of port A.
- Y** = External drain advisable when the valve is used in double flow path, see section 12.5.  
This option is mandatory if the pressure in port T exceeds 210 bar.

**Hand lever option** - only for **DHZO-A** with spool type S3, S5, D3, D5, L3, L5.

It allows to operate the valve in absence of electrical power supply.

For detailed description of DHZO-A with hand lever option see tech. table **E138**.

**MO** = Horizontal hand lever

**BMO** = Horizontal hand lever installed at side of port A

**MV** = Vertical hand lever

**BMV** = Vertical hand lever installed at side of port A

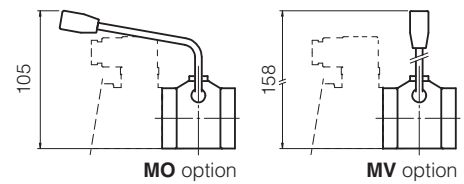

The following supplementary options allow to operate **DHZO-A** and **DKZOR-A** in absence of electrical power supply by means of a micrometric screw replacing the standard solenoid manual override, see tech. table **TK150**

**N** = Manual micrometric adjustment

**NV** = As option /N plus handwheel

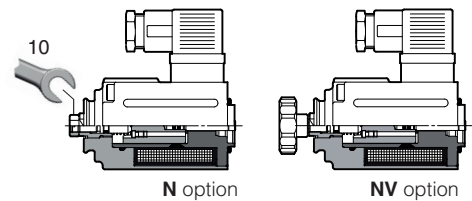

### 14 ELECTRONIC OPTIONS - only for **AEB-NP** and **AES**

- I** = This option provides  $4 \div 20$  mA current reference, instead of the standard  $\pm 10$  VDC.  
Input signal can be reconfigured via software selecting between voltage and current, within a maximum range of  $\pm 10$  VDC or  $\pm 20$  mA.  
It is normally used in case of long distance between the machine control unit and the valve or where the reference signal can be affected by electrical noise; the valve functioning is disabled in case of reference signal cable breakage.
- Q** = This option permits to inhibit the valve function without removing the power supply to the driver. Upon disable command the current to the solenoid is zeroed and the valve's spool moves to rest position.  
The option /Q is suggested for all cases where the valve has to be frequently inhibited during the machine cycle – see 17.5 for signal specifications.
- Z** = This option provides, on the 12 pin main connector, the following additional features:  
**Fault output signal** - see 17.6  
**Enable input signal** - see above option /Q  
**Power supply for driver's logics and communication** - see 17.2

### 15 POSSIBLE COMBINED OPTIONS

For **AEB-NP** and **AES**

**Hydraulic options:** /BY

**Electronic options:** /IQ, /IZ

For **AEB-IL**

**Hydraulic options:** /BY

**Note:** /T Bluetooth adapter option can be combined with all other options

### 16 COIL VOLTAGE OPTIONS - only for **A**

**6** = Optional coil to be used with Atos drivers with power supply 12 VDC.

**18** = Optional coil to be used with electronic drivers not supplied by Atos, with power supply 24 VDC and with max current limited to 1A.

## 17 POWER SUPPLY AND SIGNALS SPECIFICATIONS - only for AEB-NP and AES

Generic electrical output signals of the valve (e.g. fault or monitor signals) must not be directly used to activate safety functions, like to switch-ON/OFF the machine's safety components, as prescribed by the European standards (Safety requirements of fluid technology systems and components-hydraulics, ISO 4413).

For **AEB-IL** see section 18 for IO-Link signals specifications.

### 17.1 Power supply (V+ and V0)

The power supply must be appropriately stabilized or rectified and filtered: apply at least a 10000  $\mu\text{F}/40\text{ V}$  capacitance to single phase rectifiers or a 4700  $\mu\text{F}/40\text{ V}$  capacitance to three phase rectifiers. In case of separate power supply see 17.2.

 A safety fuse is required in series to each power supply: 2,5 A time lag fuse.

### 17.2 Power supply for driver's logic and communication (VL+ and VL0) - only for /Z option

The power supply for driver's logic and communication must be appropriately stabilized or rectified and filtered: apply at least a 10000  $\mu\text{F}/40\text{ V}$  capacitance to single phase rectifiers or a 4700  $\mu\text{F}/40\text{ V}$  capacitance to three phase rectifiers.

The separate power supply for driver's logic on pin 9 and 10, allow to remove solenoid power supply from pin 1 and 2 maintaining active the diagnostics, USB and fieldbus communications.

 A safety fuse is required in series to each driver's logic and communication power supply: 500 mA fast fuse.

### 17.3 Reference input signal (INPUT+)

The driver controls in closed loop the current to the valve proportionally to the external reference input signal.

Reference input signal is factory preset according to selected valve code, defaults are  $\pm 10\text{ V}_{\text{DC}}$  for standard and  $4 \div 20\text{ mA}$  for /I option.

Input signal can be reconfigured via software selecting between voltage and current, within a maximum range of  $\pm 10\text{ V}_{\text{DC}}$  or  $\pm 20\text{ mA}$ .

Drivers with fieldbus interface (BC, BP, EH) can be software set to receive reference signal directly from the machine control unit (fieldbus reference).

### 17.4 Monitor output signal (MONITOR)

The driver generates an analog output signal (MONITOR) proportional to the actual coil current of the valve; the monitor output signal can be software set to show other signals available in the driver (e.g. analog reference, fieldbus reference).

Monitor output signal is factory preset according to selected valve code, default settings is  $\pm 5\text{ V}_{\text{DC}}$  ( $1\text{V} = 1\text{A}$ ).

Output signal can be reconfigured via software, within a maximum range of  $\pm 5\text{ V}_{\text{DC}}$ .

### 17.5 Enable input signal (ENABLE) - not for standard

To enable the driver, supply a  $24\text{ V}_{\text{DC}}$  on pin 3 (pin C): Enable input signal allows to enable/disable the current supply to the solenoid, without removing the electrical power supply to the driver; it is used to active the communication and the other driver functions when the valve must be disabled for safety reasons. This condition **does not comply** with norms IEC 61508 and ISO 13849.

### 17.6 Fault output signal (FAULT) - only for /Z option

Fault output signal indicates fault conditions of the driver (solenoid short circuits/not connected, reference signal broken for  $4 \div 20\text{ mA}$  input, etc.).

Fault presence corresponds to  $0\text{ V}_{\text{DC}}$ , normal working corresponds to  $24\text{ V}_{\text{DC}}$ .

Fault status is not affected by the Enable input signal.

## 18 IO-LINK SIGNALS SPECIFICATIONS - only for AEB-IL

### 18.1 Power supply for IO-Link communication (L+ and L-)

The IO-Link master provides dedicated  $24\text{ V}_{\text{DC}}$  power supply for IO-Link communication.

Maximum power consumption:  $2\text{ W}$

Internal electrical isolation of power L+, L- from P24, N24

### 18.2 Power supply for driver's logic and valve regulation (P24 and N24)

The IO-Link master provides dedicated  $24\text{ V}_{\text{DC}}$  power supply for valve regulation, logics and diagnostics.

Maximum power consumption:  $50\text{ W}$

Internal electrical isolation of power P24, N24 from L+, L-

### 18.3 IO-Link data line (C/Q)

C/Q signal is used to establish communication between IO-Link master and valve.

## 19 ELECTRONIC CONNECTIONS

### 19.1 Main connector signals - 7 pin (A1) Standard and /Q option - for AEB-NP and AES

PIN	Standard	/Q	TECHNICAL SPECIFICATIONS	NOTES
A	V+		Power supply 24 Vdc	Input - power supply
B	V0		Power supply 0 Vdc	Gnd - power supply
C	AGND		Analog ground	Gnd - analog signal
		ENABLE	Enable (24 Vdc) or disable (0 Vdc) the driver, referred to V0	Input - on/off signal
D	INPUT+		Reference input signal: $\pm 10$ Vdc / $\pm 20$ mA maximum range Defaults are $\pm 10$ Vdc for standard and $4 \div 20$ mA for /I option	Input - analog signal <b>Software selectable</b>
E	INPUT-		Negative reference input signal for INPUT+	Input - analog signal
F	MONITOR referred to: AGND   V0		Monitor output signal: $\pm 5$ Vdc maximum range Default is $\pm 5$ Vdc (1V = 1A)	Output - analog signal <b>Software selectable</b>
G	EARTH		Internally connected to driver housing	

### 19.2 Main connector signals - 12 pin (A2) /Z option - for AEB-NP and AES

PIN	SIGNAL	TECHNICAL SPECIFICATIONS	NOTES
1	V+	Power supply 24 Vdc	Input - power supply
2	V0	Power supply 0 Vdc	Gnd - power supply
3	ENABLE	Enable (24 Vdc) or disable (0 Vdc) the driver, referred to VLO	Input - on/off signal
4	INPUT+	Reference input signal: $\pm 10$ Vdc / $\pm 20$ mA maximum range Defaults are $\pm 10$ Vdc for standard and $4 \div 20$ mA for /I option	Input - analog signal <b>Software selectable</b>
5	INPUT-	Negative reference input signal for INPUT+	Input - analog signal
6	MONITOR	Monitor output signal: $\pm 5$ Vdc maximum range, referred to VLO Default is $\pm 5$ Vdc (1V = 1A)	Output - analog signal <b>Software selectable</b>
7	NC	Do not connect	
8	NC	Do not connect	
9	VL+	Power supply 24 Vdc for driver's logic and communication	Input - power supply
10	VLO	Power supply 0 Vdc for driver's logic and communication	Gnd - power supply
11	FAULT	Fault (0 Vdc) or normal working (24 Vdc), referred to VLO	Output - on/off signal
PE	EARTH	Internally connected to driver housing	

**Note:** do not disconnect VLO before VL+ when the driver is connected to PC USB port

### 19.3 IO-Link connector signals - M12 - 5 pin - Coding A, port class B (A) only for AEB-IL

PIN	SIGNAL	TECHNICAL SPECIFICATIONS	NOTES
1	L+	Power supply 24 Vdc for IO-Link communication	Input - power supply
2	P24	Power supply 24 Vdc for valve regulation, logics and diagnostics	Input - power supply
3	L-	Power supply 0 Vdc for IO-Link communication	Gnd - power supply
4	C/Q	IO-Link data line	Input / Output - signal
5	N24	Power supply 0 Vdc for valve regulation, logics and diagnostics	Gnd - power supply

Valve to Master connection examples

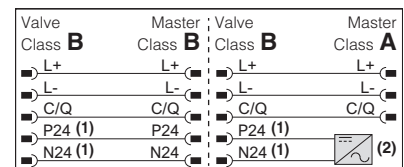

- (1) Maximum power consumption: 50 W  
(2) External power supply

**Note:** L+, L- and P24, N24 are electrically isolated

### 19.4 Communication connectors - for AEB (B) and AES (B) - (C)

(B) USB connector - M12 - 5 pin always present		
PIN	SIGNAL	TECHNICAL SPECIFICATION (1)
1	+5V_USB	Power supply
2	ID	Identification
3	GND_USB	Signal zero data line
4	D-	Data line -
5	D+	Data line +

(C1) BC fieldbus execution, connector - M12 - 5 pin (2)		
PIN	SIGNAL	TECHNICAL SPECIFICATION (1)
1	CAN_SHLD	Shield
2	NC	do not connect
3	CAN_GND	Signal zero data line
4	CAN_H	Bus line (high)
5	CAN_L	Bus line (low)

(C2) BP fieldbus execution, connector - M12 - 5 pin (2)		
PIN	SIGNAL	TECHNICAL SPECIFICATION (1)
1	+5V	Termination supply signal
2	LINE-A	Bus line (high)
3	DGND	Data line and termination signal zero
4	LINE-B	Bus line (low)
5	SHIELD	

(C3) (C4) EH fieldbus execution, connector - M12 - 4 pin (2)		
PIN	SIGNAL	TECHNICAL SPECIFICATION (1)
1	TX+	Transmitter
2	RX+	Receiver
3	TX-	Transmitter
4	RX-	Receiver
Housing	SHIELD	

(1) Shield connection on connector's housing is recommended

(2) Only for AES execution

### 19.5 Solenoid connection - only for A

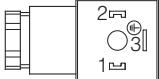
PIN	SIGNAL	TECHNICAL SPECIFICATION	Connector code 666 
1	COIL	Power supply	
2	COIL	Power supply	
3	GND	Ground	

## 19.6 AEB-NP connections layout

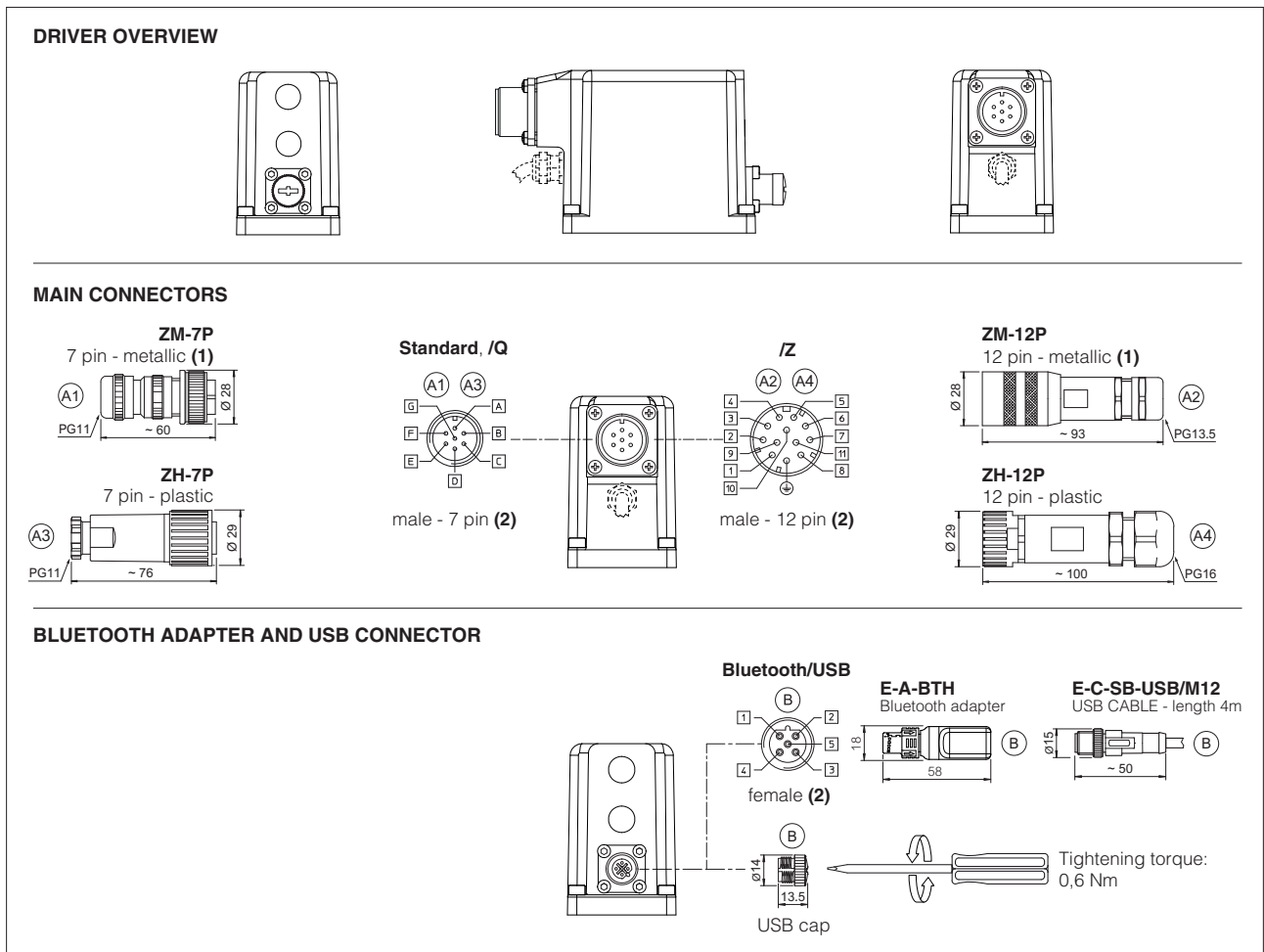

(1) Use of metallic connectors is strongly recommended in order to fulfill EMC requirements (2) Pin layout always referred to driver's view

## 19.7 AEB-IL connections layout

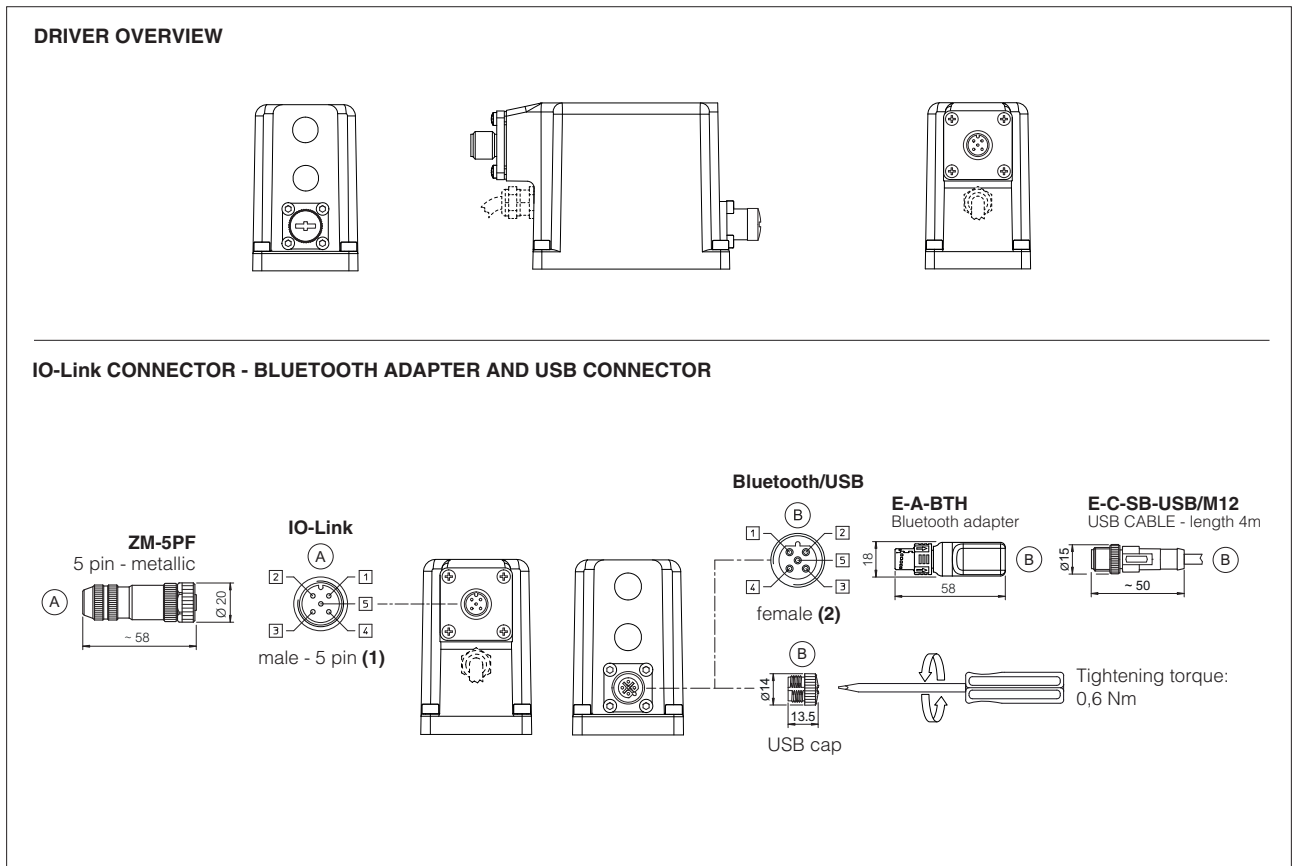

(1) Use of metallic connectors is strongly recommended in order to fulfill EMC requirements (2) Pin layout always referred to driver's view

**DRIVER OVERVIEW**

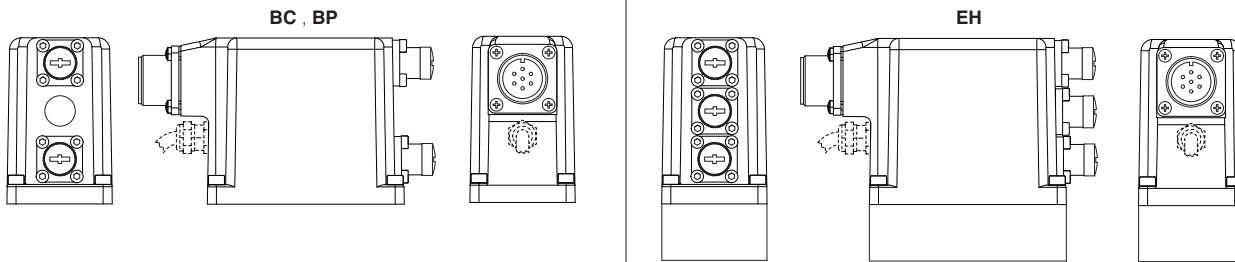

**MAIN CONNECTORS**

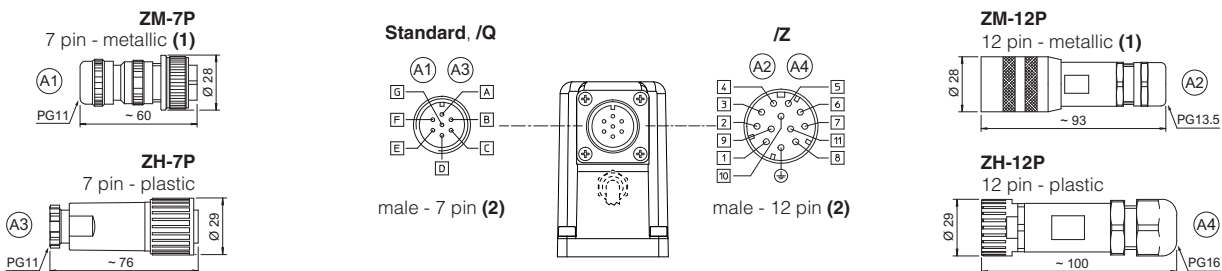

**FIELDBUS CONNECTORS**

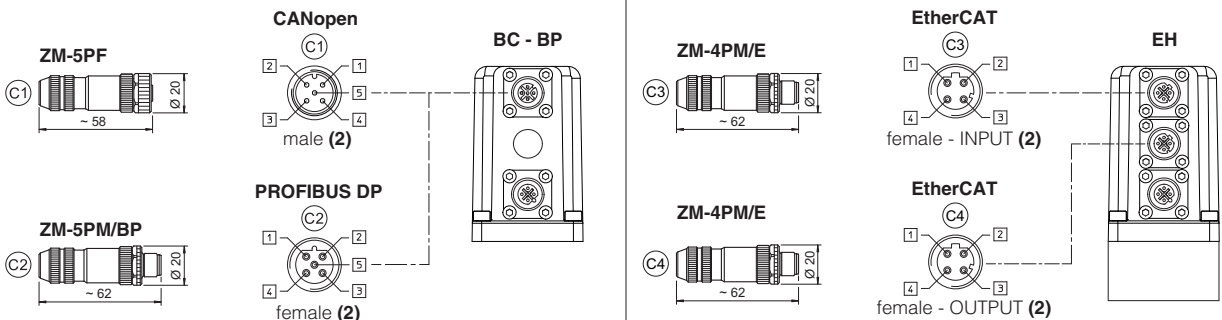

**BLUETOOTH ADAPTER AND USB CONNECTOR**

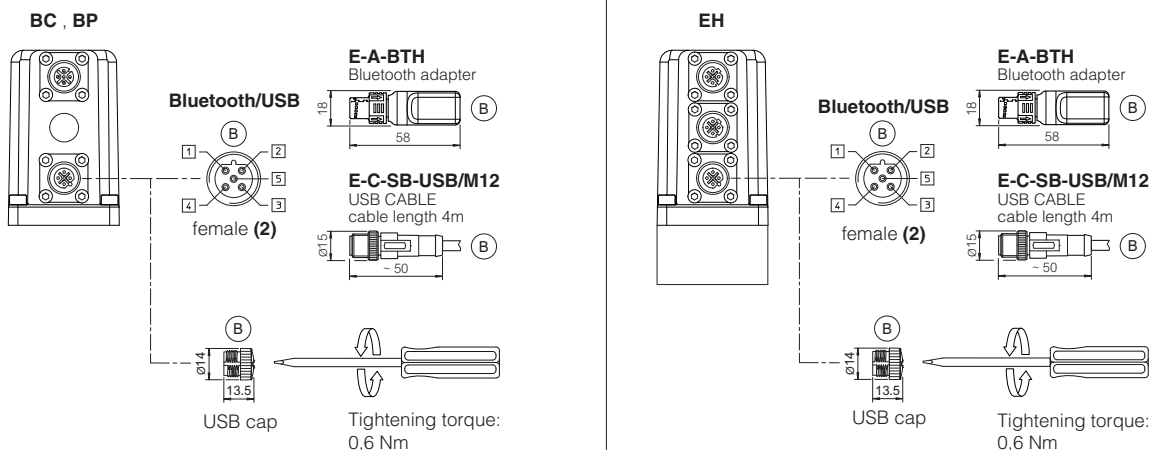

(1) Use of metallic connectors is strongly recommended in order to fulfill EMC requirements (2) Pin layout always referred to driver's view

**20 CONNECTORS CHARACTERISTICS** - to be ordered separately

**20.1 Main connectors - 7 pin - for AEB-NP and AES**

CONNECTOR TYPE	POWER SUPPLY AND SIGNALS	POWER SUPPLY AND SIGNALS
<b>CODE</b>	<b>(A1) ZM-7P</b>	<b>(A3) ZH-7P</b>
Type	7pin female straight circular	7pin female straight circular
Standard	According to MIL-C-5015	According to MIL-C-5015
Material	Metallic	Plastic reinforced with fiber glass
Cable gland	PG11	PG11
Recommended cable	LiYCY 7 x 0,75 mm <sup>2</sup> max 20 m (logic and power supply) or LiYCY 7 x 1 mm <sup>2</sup> max 40 m (logic and power supply)	LiYCY 7 x 0,75 mm <sup>2</sup> max 20 m (logic and power supply) or LiYCY 7 x 1 mm <sup>2</sup> max 40 m (logic and power supply)
Conductor size	up to 1 mm <sup>2</sup> - available for 7 wires	up to 1 mm <sup>2</sup> - available for 7 wires
Connection type	to solder	to solder
Protection (EN 60529)	IP 67	IP 67

**20.2 Main connectors - 12 pin - for AEB-NP and AES**

CONNECTOR TYPE	POWER SUPPLY AND SIGNALS	POWER SUPPLY AND SIGNALS
<b>CODE</b>	<b>(A2) ZM-12P</b>	<b>(A4) ZH-12P</b>
Type	12pin female straight circular	12pin female straight circular
Standard	DIN 43651	DIN 43651
Material	Metallic	Plastic reinforced with fiber glass
Cable gland	PG13,5	PG16
Recommended cable	LiYCY 12 x 0,75 mm <sup>2</sup> max 20 m (logic and power supply)	LiYCY 10 x 0,14mm <sup>2</sup> max 40 m (logic) LiYY 3 x 1mm <sup>2</sup> max 40 m (power supply)
Conductor size	0,5 mm <sup>2</sup> to 1,5 mm <sup>2</sup> - available for 12 wires	0,14 mm <sup>2</sup> to 0,5 mm <sup>2</sup> - available for 9 wires 0,5 mm <sup>2</sup> to 1,5 mm <sup>2</sup> - available for 3 wires
Connection type	to crimp	to crimp
Protection (EN 60529)	IP 67	IP 67

**20.3 IO-Link connector - only for AEB-IL**

CONNECTOR TYPE	IL IO-Link
<b>CODE</b>	<b>(A) ZM-5PF</b>
Type	5pin female straight circular
Standard	M12 coding A – IEC 61076-2-101
Material	Metallic
Cable gland	Pressure nut - cable diameter 6÷8 mm
Recommended cable	5 x 0,75 mm <sup>2</sup> max 20 m
Connection type	screw terminal
Protection (EN 60529)	IP 67

**20.4 Fieldbus communication connectors - only for AES**

CONNECTOR TYPE	BC CANopen (1)	BP PROFIBUS DP (1)	EH EtherCAT (2)
<b>CODE</b>	<b>(C1) ZM-5PF</b>	<b>(C2) ZM-5PM/BP</b>	<b>(C3) (C4) ZM-4PM/E</b>
Type	5 pin female straight circular	5 pin male straight circular	4 pin male straight circular
Standard	M12 coding A – IEC 61076-2-101	M12 coding B – IEC 61076-2-101	M12 coding D – IEC 61076-2-101
Material	Metallic	Metallic	Metallic
Cable gland	Pressure nut - cable diameter 6÷8 mm	Pressure nut - cable diameter 6÷8 mm	Pressure nut - cable diameter 4÷8 mm
Cable	CANbus Standard (DR 303-1)	PROFIBUS DP Standard	Ethernet standard CAT-5
Connection type	screw terminal	screw terminal	terminal block
Protection (EN 60529)	IP67	IP 67	IP 67

(1) E-TRM-\*\* terminators can be ordered separately - see tech table **GS500**

(2) Internally terminated

21 INSTALLATION DIMENSIONS FOR DHZO [mm]

ISO 4401: 2005  
 Mounting surface: 4401-03-02-0-05 (see table P005)  
 (for /Y version, surface 4401-03-03-0-05 without X port)

	Mass [kg]		
	A	AEB, AES	AES-EH
DHZO-*-05	1,9	2,3	2,4
DHZO-*-07	2,6	3,1	3,2

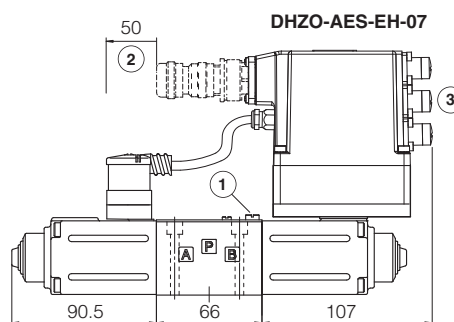
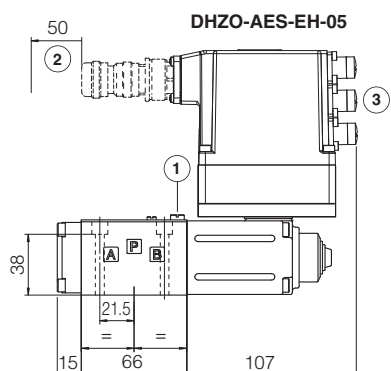
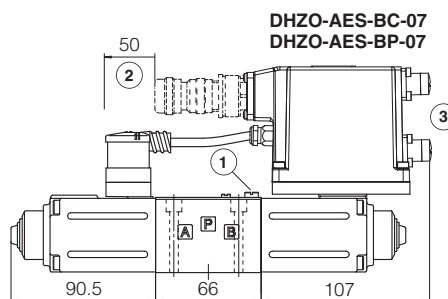
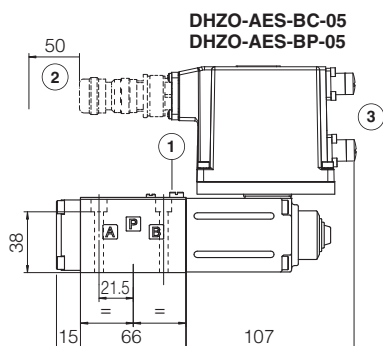
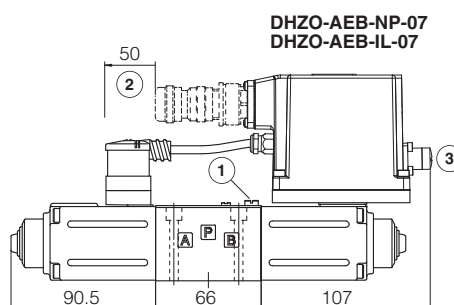
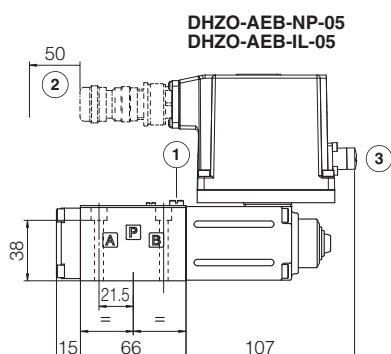
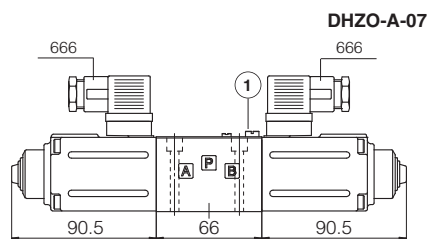
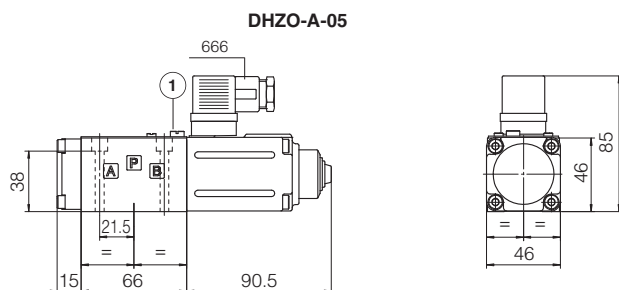

- ① = Air bleeding 3
- ② = Space required for connection cable and for connector removal
- ③ = The dimensions of connectors and Bluetooth adapter must be considered, see section 19.6, 19.7 and 19.8

**Note:** for /B option the solenoid and the on-board digital driver are at side of port A

22 INSTALLATION DIMENSIONS FOR DKZOR [mm]

ISO 4401: 2005

Mounting surface: 4401-05-04-0-05 (see table P005)

(for /Y version, surface 4401-05-05-0-05 without X port)

	Mass [kg]		
	A	AEB, AES	AES-EH
DKZOR-*-15	3,8	4,3	4,4
DKZOR-*-17	4,5	5,0	5,1

DKZOR-A-15

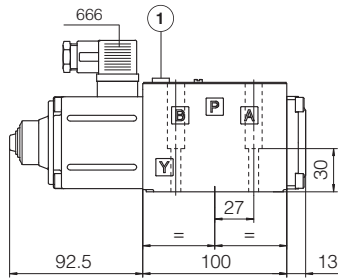

DKZOR-A-17

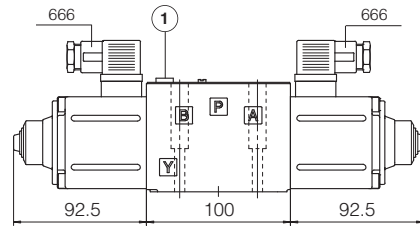

DKZOR-AEB-NP-15  
DKZOR-AEB-IL-15

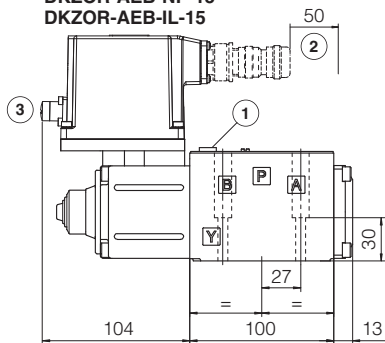

DKZOR-AEB-NP-17  
DKZOR-AEB-IL-17

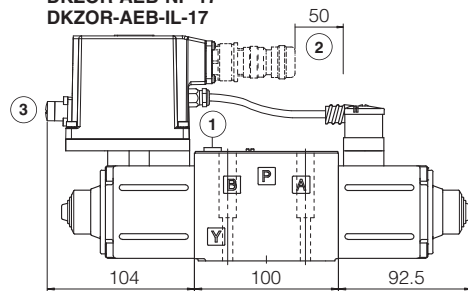

DKZOR-AES-BC-15  
DKZOR-AES-BP-15

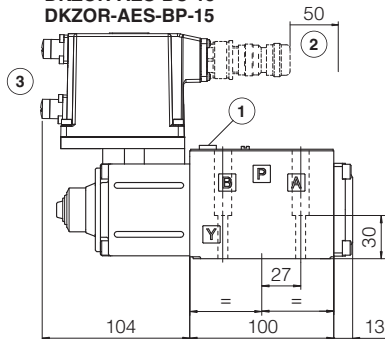

DKZOR-AES-BC-17  
DKZOR-AES-BP-17

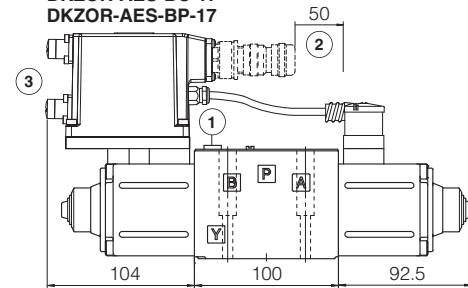

DKZOR-AES-EH-15

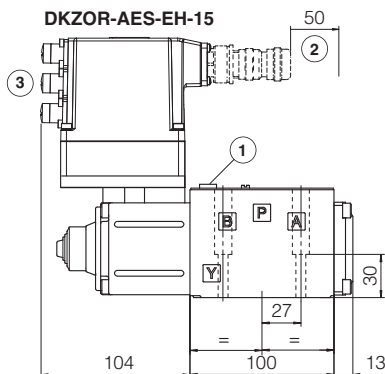

DKZOR-AES-EH-17

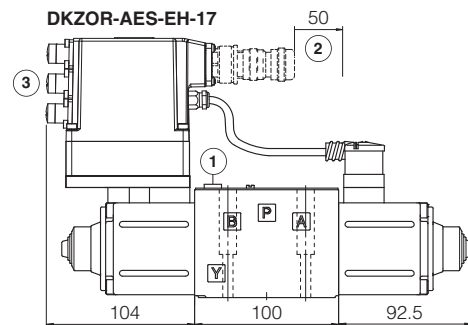



① = Air bleeding 

② = Space required for connection cable and for connector removal

③ = The dimensions of connectors and Bluetooth adapter must be considered, see section 19.6, 19.7 and 19.8

**Note:** for /B option the solenoid and the on-board digital driver are at side of port A

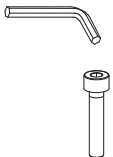
**23 FASTENING BOLTS AND SEALS**

	<p><b>DHZO</b></p>	<p><b>DKZOR</b></p>
	<p><b>Fastening bolts:</b> 4 socket head screws M5x50 class 12.9 Tightening torque = 8 Nm</p>	<p><b>Fastening bolts:</b> 4 socket head screws M6x40 class 12.9 Tightening torque = 15 Nm</p>
	<p><b>Seals:</b> 4 OR 108 Diameter of ports A, B, P, T: Ø 7,5 mm (max) 1 OR 2025 Diameter of port Y: Ø 3,2 mm (only for /Y option)</p>	<p><b>Seals:</b> 5 OR 2050 Diameter of ports A, B, P, T: Ø 11,2 mm (max) 1 OR 108 Diameter of port Y: Ø 5 mm (only for /Y option)</p>

**24 RELATED DOCUMENTATION**

<p><b>FS001</b> Basics for digital electrohydraulics  <b>FS900</b> Operating and maintenance information for proportional valves  <b>G010</b> E-MI-AC analog driver  <b>G020</b> E-MI-AS-IR digital driver  <b>G030</b> E-BM-AS digital driver  <b>GS050</b> E-BM-AES digital driver  <b>GS500</b> Programming tools  <b>GS510</b> Fieldbus  <b>GS520</b> IO-Link interface</p>	<p><b>K800</b> Electric and electronic connectors  <b>P005</b> Mounting surfaces for electrohydraulic valves  <b>QB100</b> Quickstart for AEB valves commissioning  <b>QF100</b> Quickstart for AES valves commissioning  <b>E-MAN-MI-AS</b> E-MI-AS-IR user manual (off-board)  <b>E-MAN-BM-AS</b> E-BM-AS user manual (off-board)  <b>E-MAN-BM-AES</b> E-BM-AES user manual (off-board)  <b>E-MAN-RI-AEB</b> AEB user manual  <b>E-MAN-RI-AES</b> AES user manual</p>
---	---