

Ex-proof digital proportional reducing valves high performance

direct or piloted, with on-board driver and pressure transducer - **ATEX, IECEx, EAC, CCC**

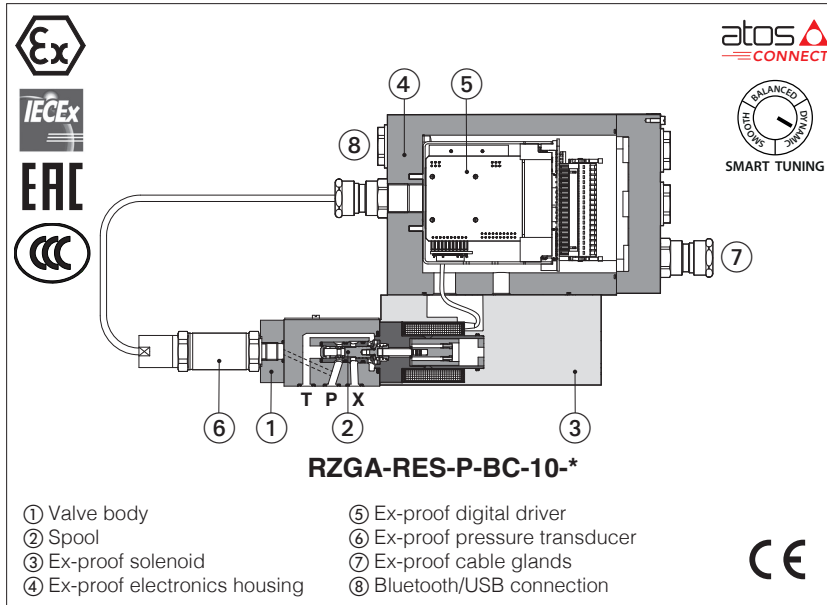

RZGA-RES, AGRCZA-RES

Ex-proof digital, high performance proportional reducing valves, direct or piloted, with pressure transducer for pressure closed loop controls.

They are equipped with ex-proof on-board digital driver, pressure transducer and proportional solenoids certified for safe operations in hazardous environments with potentially explosive atmosphere.

- Multicertification **ATEX, IECEx, EAC, CCC** for gas group **II 2G**

The flameproof enclosure of on-board digital driver, solenoid and transducer, prevents the propagation of accidental internal sparks or fire to the external environment.

The driver and solenoid are also designed to limit the surface temperature within the classified limits.

RZGA, direct or piloted:

Size: **06** - ISO 4401
Max flow: **12** and **40** l/min

AGRCZA, piloted:

Size: **10** and **20** - ISO 5871
Max flow: **160** and **300** l/min

Max pressure: **250 bar**

1 MODEL CODE

RZGA	-	RES	-	P	-	NP	-	010	/	210	/	M	/	*	/	*	/	*
<p>Ex-proof proportional pressure reducing valves RZGA = subplate size 06 AGRCZA = subplate size 10, 20</p> <p>RES = on-board driver</p> <p>P = on-board ex-proof pressure transducer</p> <p>Fieldbus interface, see section 5:</p> <p>NP = Not Present BC = CANopen BP = PROFIBUS DP EH = EtherCAT</p> <p>Valve size and configuration: RZGA: direct 010 = Qmax 12 l/min RZGA: piloted 033 = Qmax 40 l/min AGRCZA: piloted 10, 20 = Qmax 160, 300 l/min</p> <p>Seals material, see section 9: - = NBR PE = FKM BT = NBR low temp.</p> <p>Hydraulic options - only AGRCZA (1): P = with integral mechanical pressure limiter R = with integral check valve for free reverse flow</p> <p>Electronic options (1): I = current reference input and monitor 4 ÷ 20 mA</p> <p>Cable entrance threaded connection: M = M20x1,5</p> <p>Max regulated pressure: only for RZGA-010 32 = 32 bar 100 = 100 bar 210 = 210 bar only for RZGA-033 and AGRCZA 80 = 80 bar 180 = 180 bar 250 = 250 bar</p>																		

(1) Possible combined options: /IP, /IR, /PR

2 CONFIGURATIONS AND HYDRAULIC SYMBOLS (representation according to ISO 1219-1)

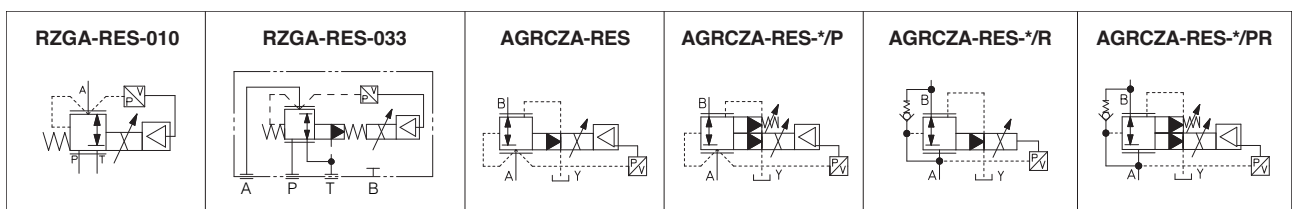

3 GENERAL NOTES

Atos digital proportionals valves are CE marked according to the applicable directives (e.g. Immunity and Emission EMC Directive). Installation, wirings and start-up procedures must be performed according to the general prescriptions shown in tech table **FX900** and in the user manuals included in the E-SW-SETUP programming software.

4 VALVE SETTINGS AND PROGRAMMING TOOLS - see tech. table **GS500**

WARNING: the below operation must be performed in a safety area!

4.1 Atos CONNECT mobile App

Free downloadable App for smartphones and tablets which allows quick access to valve main functional parameters and basic diagnostic information via Bluetooth, thus avoiding physical cable connection and significantly reducing commissioning time. Atos CONNECT supports Atos digital valve drivers equipped with E-A-BTH adapter or with built-in Bluetooth. It does not support valves with p/Q control or axis controls.



4.2 E-SW-SETUP PC software

Free downloadable software for PC allows to set all valve functional parameters and to access complete diagnostic information of digital valve drivers via Bluetooth/USB service port. Atos E-SW-SETUP PC software supports all Atos digital valve drivers and it is available at www.atos.com in MyAtos area.

WARNING: drivers USB port is not isolated! For E-C-SB-USB/M12 cable, the use of E-A-SB-USB/OPT isolator adapter is highly recommended for PC protection

WARNING: for the list of countries where the Bluetooth adapter has been approved, see tech. table **GS500**

Bluetooth or USB connection

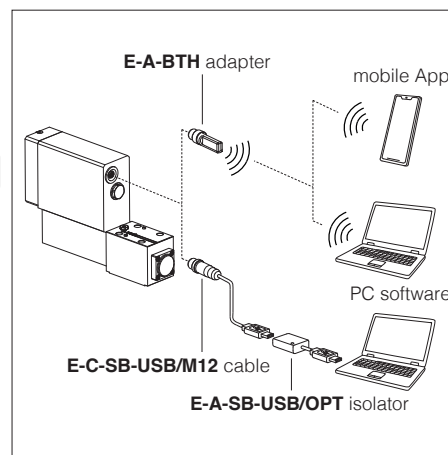

5 FIELDBUS - see tech. table **GS510**

Fieldbus allows valve direct communication with machine control unit for digital reference, valve diagnostics and settings. These executions allow to operate the valves through fieldbus or analog signals available on the terminal board.

6 GENERAL CHARACTERISTICS

Assembly position	Any position
Subplate surface finishing to ISO 4401	Acceptable roughness index, Ra ≤ 0,8 recommended Ra 0,4 - flatness ratio 0,01/100
MTTFd values according to EN ISO 13849	RZGA-010 150 years, RZGA-033 and AGRCZA 75 years see technical table P007
Ambient temperature range	Standard = -20°C ÷ +60°C /PE option = -20°C ÷ +60°C /BT option = -40°C ÷ +60°C
Storage temperature range	Standard = -20°C ÷ +70°C /PE option = -20°C ÷ +70°C /BT option = -40°C ÷ +70°C
Surface protection	Zinc coating with black passivation
Corrosion resistance	Salt spray test (ISO 9227) > 200 h
Vibration resistance	See technical table GX004
Compliance	Explosion proof protection, see section 10 -Flame proof enclosure "Ex d" RoHs Directive 2011/65/EU as last update by 2015/863/EU REACH Regulation (EC) n°1907/2006

7 HYDRAULIC CHARACTERISTICS - based on mineral oil ISO VG 46 at 50 °C

Valve model	RZGA			AGRCZA	
	010	033		10	20
Size code	06	06		10	20
Valve size					
Max regulated pressure [bar]	32	100	210	80	180
Max pressure at port P, A, B, X [bar]	315				
Max pressure at port T, Y [bar]	210				
Min regulated pressure [bar]	0,8	2,5		1,0	
Max flow [l/min]	12	40		160	300
Response time 0-100% step signal (depending on installation) (1) [ms]	≤ 50			≤ 60	
Hysteresis [% of the max pressure]	≤ 0,3				
Linearity [% of the max pressure]	≤ 1,0				
Repeatability [% of the max pressure]	≤ 0,2				

(1) Average response time value; the pressure variation in consequence of a modification of the reference input signal to the valve is affected by the stiffness of the hydraulic circuit: greater is the stiffness of the circuit, faster is the dynamic response

8 ELECTRICAL CHARACTERISTICS

Power supplies	Nominal : +24 VDC Rectified and filtered : VRMS = 20 ÷ 32 VMAX (ripple max 10 % VPP)			
Max power consumption	35 W			
Analog input signals	Voltage: range ±10 VDC (24 VMAX tolerant) Current: range ±20 mA		Input impedance: Ri > 50 kΩ Input impedance: Ri = 500 Ω	
Insulation class	H (180°) Due to the occurring surface temperatures of the solenoid coils, the European standards ISO 13732-1 and EN982 must be taken into account			
Monitor outputs	Voltage: range 0 ÷ 10 VDC @ max 5 mA Current: range 0 ÷ 20 mA @ max 500 Ω load resistance			
Enable input	Range: 0 ÷ 9 VDC (OFF state), 15 ÷ 24 VDC (ON state), 9 ÷ 15 VDC (not accepted); Input impedance: Ri > 87 kΩ			
Fault output	Output range : 0 ÷ 24 Vdc (ON state ≡ VL+ [logic power supply] ; OFF state ≡ 0 V) @ max 50 mA; external negative voltage not allowed (e.g. due to inductive loads)			
Pressure transducer power supply (1)	+24Vdc @ max 100 mA (E-ATRA-7 see tech table GX800)			
Alarms	Solenoid not connected/short circuit, cable break with current reference signal, over/under temperature, power supplies level, pressure transducer failure			
Protection degree to DIN EN60529	IP66 / IP67 with relevant cable gland			
Duty factor	Continuous rating (ED=100%)			
Tropicalization	Tropical coating on electronics PCB			
Additional characteristics	Short circuit protection of solenoid current supply; current control by P.I.D. with rapid solenoid switching; protection against reverse polarity of power supply			
Electromagnetic compatibility (EMC)	According to Directive 2014/30/UE (Immunity: EN 61000-6-2; Emission: EN 610006-3)			
Communication interface	USB Atos ASCII coding	CANopen EN50325-4 + DS408	PROFIBUS DP EN50170-2/IEC61158	EtherCAT, EC 61158
Communication physical layer	not insulated USB 2.0 + USB OTG	optical insulated CAN ISO11898	optical insulated RS485	Fast Ethernet, insulated 100 Base TX

- (1) In case of pressure transducer failure, the valve's reaction can be configured through Atos E-SW-SETUP software to:
- cut off the current to solenoid, therefore the regulated pressure will be reduced to minimum value (default setting)
 - automatically switch the pressure control from closed loop (dynamic, balanced, smooth) to open loop, to let the valve to temporarily operate with reduced regulation accuracy

Note: a maximum time of 500 ms (depending on communication type) has to be considered between the driver energizing with the 24 VDC power supply and when the valve is ready to operate. During this time the current to the valve coils is switched to zero

9 SEALS AND HYDRAULIC FLUIDS - for other fluids not included in below table, consult our technical office

Seals, recommended fluid temperature	NBR seals (standard) = -20°C ÷ +60°C, with HFC hydraulic fluids = -20°C ÷ +50°C FKM seals (/PE option) = -20°C ÷ +80°C NBR low temp. seals (/BT option) = -40°C ÷ +60°C, with HFC hydraulic fluids = -20°C ÷ +50°C		
Recommended viscosity	20 ÷ 100 mm ² /s - max allowed range 15 ÷ 380 mm ² /s		
Max fluid contamination level	normal operation	ISO4406 class 18/16/13 NAS1638 class 7	see also filter section at
	longer life	ISO4406 class 16/14/11 NAS1638 class 5	www.atos.com or KTF catalog
Hydraulic fluid	Suitable seals type	Classification	Ref. Standard
Mineral oils	NBR, FKM, NBR low temp.	HL, HLP, HLPD, HVLP, HVLDP	DIN 51524
Flame resistant without water	FKM	HFDU, HFDR	ISO 12922
Flame resistant with water (1)	NBR, NBR low temp.	HFC	

⚠ The ignition temperature of the hydraulic fluid must be 50°C higher than the max solenoid surface temperature

(1) **Performance limitations in case of flame resistant fluids with water:**
- max operating pressure = 210 bar - max fluid temperature = 50°C

10 CERTIFICATION DATA

Valve type	RZGA, AGRCZA					
Certifications	Solenoid data			Pressure transducer data		
	ATEX	IECEX	EAC	CCC	ATEX	IECEX
Certified code	OZA-RES			Pressure transmitter, Series E-10		
Type examination certificate (1)	<ul style="list-style-type: none"> • ATEX: CESI 02 ATEX 014 • IECEX: IECEX CES 10.0010x • EAC: RU C - IT.AX38.B.00425/21 • CCC: 2024322307006321 			<ul style="list-style-type: none"> • ATEX: KEMA 05 ATEX 2240 X • IECEX: IECEX DEK 15.0048X • EAC: C-DE.AA71.B.00162/19 		
Method of protection	<ul style="list-style-type: none"> • ATEX Ex II 2G Ex db IIC T4/T3 Gb Ex II 2D Ex tb IIIC T135°C/T200°C Db • IECEX, CCC Ex db IIC T4/T3 Gb Ex tb IIIC T135°C/T200°C Db • EAC 1Ex d IIC T4/T3 Gb X Ex tb IIIC T135°C/T200°C Db X 			<ul style="list-style-type: none"> • ATEX, EAC Ex II 2G Ex db IIC T6...T1 Gb • IECEX Ex db IIC T6...T1 Gb 		
Temperature class	T6	T5	T4	T6	T5	T4
Surface temperature	≤ 85 °C	≤ 100 °C	≤ 135 °C	≤ 85 °C	≤ 100 °C	≤ 135 °C
Ambient temperature (2)	-40 ÷ +40 °C	-40 ÷ +55 °C	-40 ÷ +70 °C	-40 ÷ +40 °C	-40 ÷ +55 °C	-40 ÷ +70 °C
Applicable standards	EN 60079-0; IEC 60079-0;	EN 60079-1; IEC 60079-1;	EN 60079-31 IEC 60079-31	EN 60079-0; IEC 60079-0;	EN 60079-1; IEC 60079-1;	
Cable entrance: threaded connection	GK = GK-1/2"	M = M20x1,5	NPT = 1/2" NPT			

(1) The type examination certificates can be downloaded from www.atos.com

(2) The driver and solenoids are certified for minimum ambient temperature -40°C.

In case the complete valve must withstand with minimum ambient temperature -40°C, select /BT in the model code.

⚠ **WARNING: service work performed on the valve by the end users or not qualified personnel invalidates the certification**

11 CABLE SPECIFICATION AND TEMPERATURE - Power supply and grounding cables have to comply with following characteristics:

Power supply and signals: section of wire = 1,0 mm ²	Grounding: section of external ground wire = 4 mm ²
--	---

11.1 Cable temperature

The cable must be suitable for the working temperature as specified in the "safety instructions" delivered with the first supply of the products.

Max ambient temperature [°C]	Temperature class	Max surface temperature [°C]	Min. cable temperature [°C]
40 °C	T6	85 °C	80 °C
55 °C	T5	100 °C	90 °C
70 °C	T4	135 °C	110 °C

12 CABLE GLANDS

Cable glands with threaded connections M20x1,5 for standard or armoured cables have to be ordered separately, see tech table **KX800**

Note: a Loctite sealant type 545, should be used on the cable gland entry threads

13 HYDRAULIC OPTIONS - only for AGRCZA

P = The AGRCZA are provided with mechanical pressure limiter acting as protection against overpressure. For safety reasons the factory setting of the mechanical pressure limiter is fully unloaded (min pressure).

At the first commissioning it must be set at a value lightly higher than the max pressure regulated with the proportional control.

For the pressure setting of the mechanical pressure limiter, proceed according to following steps:

- apply the max reference input signal to the valve's driver. The system pressure will not increase until the mechanical pressure limiter remains unloaded
- turn clockwise the adjustment screw ① until the system pressure will increase up to a stable value corresponding to the pressure setpoint at max reference input signal
- turn clockwise the adjustment screw ① of additional 1 or 2 turns to ensure that the mechanical pressure limiter remains closed during the proportional valve working

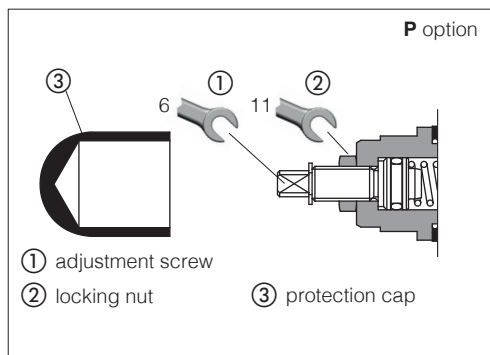

R = The AGRCZA are provided with integral check valve for free reverse flow A→B

- ① Check valve - cracking pressure = 0,5 bar
- ② Plug

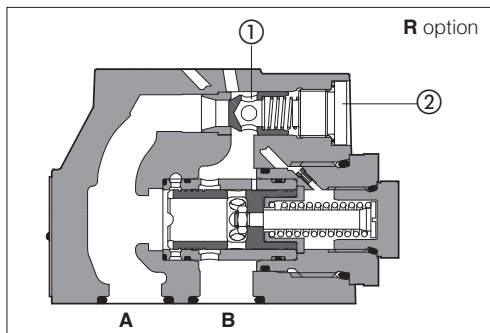

14 ELECTRONIC OPTIONS

I = It provides 4 ÷ 20 mA current reference signal, instead of the standard 0 ÷ 10 Vdc. Input signal can be reconfigured via software selecting between voltage and current, within a maximum range of ±10 Vdc or ±20 mA. It is normally used in case of long distance between the machine control unit and the valve or where the reference signal can be affected by electrical noise; the valve functioning is disabled in case of reference signal cable breakage.

15 POSSIBLE COMBINED OPTIONS

/IP, /IR, /PR

16 SMART TUNING

Smart tuning allows to adjust the valve dynamic response in order to match different hydraulic conditions and performance requirements.

The valve is provided with 3 factory settings for the pressure control:

- **dynamic** fast response time for best dynamic performances. Default factory setting for pressure valves
- **balanced** average response time suitable for major applications
- **smooth** attenuated response time for slow regulation without overshoots

Smart tuning setting can be switched from Dynamic (default) to Balanced or Smooth via software or fieldbus; if requested, performances can be further customized directly tuning each single control parameter. For details consult related manuals E-MAN-*, see section [27].

Below indications have to be considered as a general guideline, being affected by hydraulic circuit stiffness, working flow and dead volume.

17 DIAGRAMS RZGA-010 (based on mineral oil ISO VG 46 at 50 °C)

1 Regulation diagrams
with flow rate $Q = 1$ l/min

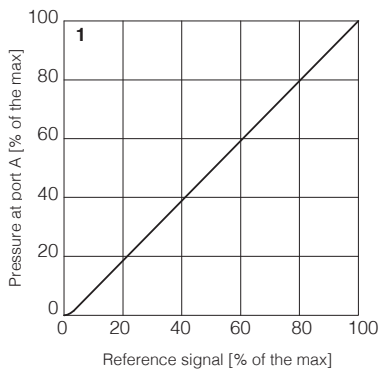

2 Pressure/flow diagrams
with reference signal set at $Q = 1$ l/min

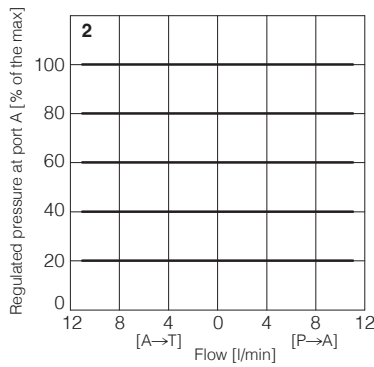

3-4 Min. pressure/flow diagrams
with zero reference signal

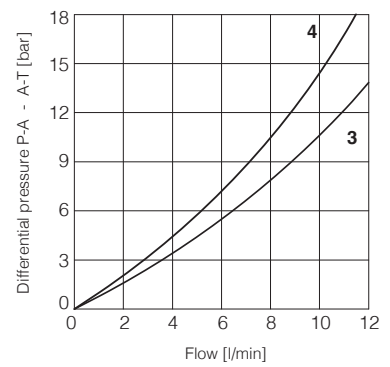

3 = Pressure drops vs. flow P→A
4 = Pressure drops vs. flow A→T

18 DIAGRAMS RZGA-033 (based on mineral oil ISO VG 46 at 50 °C)

1 Regulation diagrams
with flow rate $Q = 10$ l/min

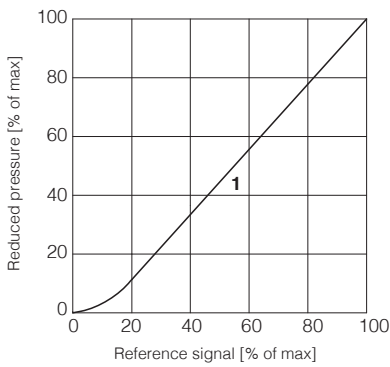

2 Pressure/flow diagrams
with reference pressure set with $Q = 10$ l/min

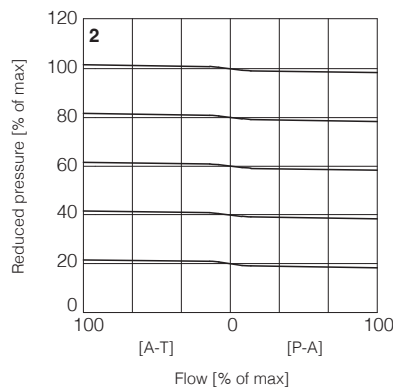

3-4 Pressure drop/flow diagram

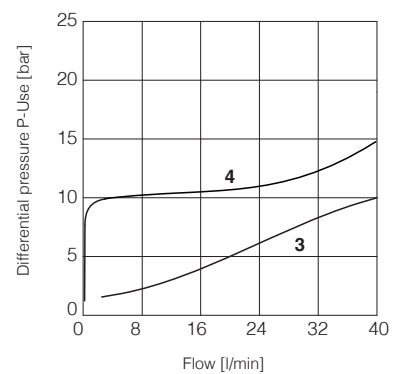

3 = A-T **4** = P-A

Note: the presence of counter pressure at port T can affect the effective pressure regulation

19 DIAGRAMS AGRCZA (based on mineral oil ISO VG 46 at 50 °C)

1 Regulation diagrams
with flow rate $Q = 10$ l/min

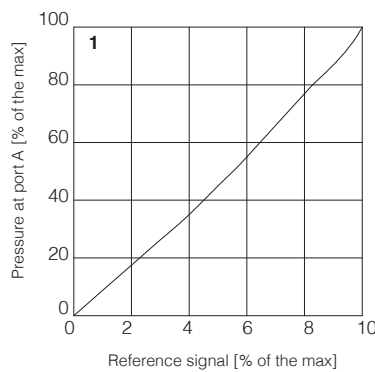

2 Pressure/flow diagrams
with reference pressure set with $Q = 10$ l/min

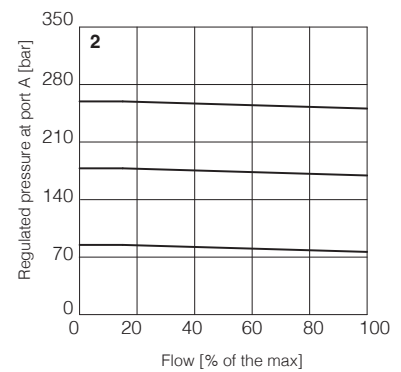

3-6 Pressure drop/flow diagrams
with zero reference signal

Differential pressure B→A

3 = AGRCZA-*-10
4 = AGRCZA-*-20

Differential pressure A→B
(through check valve)

5 = AGRCZA-*-10*/R
6 = AGRCZA-*-20*/R

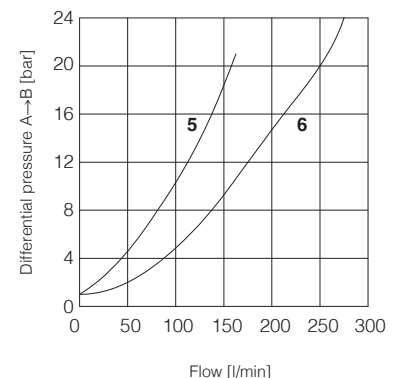
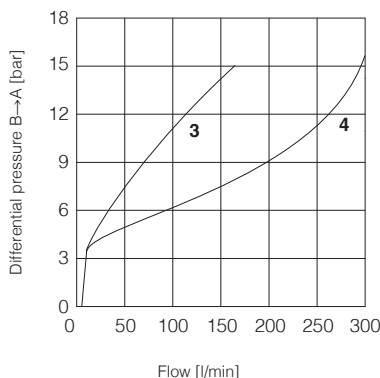

20 POWER SUPPLY AND SIGNALS SPECIFICATIONS

Generic electrical output signals of the valve (e.g. fault or monitor signals) must not be directly used to activate safety functions, like to switch-ON/OFF the machine's safety components, as prescribed by the European standards (Safety requirements of fluid technology systems and components-hydraulics, ISO 4413).

20.1 Power supply (V+ and V0)

The power supply must be appropriately stabilized or rectified and filtered: apply at least a 10000 $\mu\text{F}/40\text{ V}$ capacitance to single phase rectifiers or a 4700 $\mu\text{F}/40\text{ V}$ capacitance to three phase rectifiers.

 A safety fuse is required in series to each power supply: 2,5 A time lag fuse.

20.2 Power supply for driver's logic and communication (VL+ and VL0)

The power supply for driver's logic and communication must be appropriately stabilized or rectified and filtered: apply at least a 10000 $\mu\text{F}/40\text{ V}$ capacitance to single phase rectifiers or a 4700 $\mu\text{F}/40\text{ V}$ capacitance to three phase rectifiers.

The separate power supply for driver's logic on pin 3 and 4, allow to remove solenoid power supply from pin 1 and 2 maintaining active the diagnostics, USB and fieldbus communications.

 A safety fuse is required in series to each driver's logic and communication power supply: 500 mA fast fuse.

20.3 Pressure reference input signal (P_INPUT+)

The driver controls in closed loop the current to the valve pressure proportionally to the external reference input signal.

Reference input signal is factory preset according to selected valve code, defaults are 0 \div 10 Vdc for standard and 4 \div 20 mA for /I option.

Input signal can be reconfigured via software selecting between voltage and current, within a maximum range of $\pm 10\text{ Vdc}$ or $\pm 20\text{ mA}$.

Drivers with fieldbus interface can be software set to receive reference signal directly by the machine control unit (fieldbus reference).

Analog reference input signal can be used as on-off commands with input range 0 \div 24Vdc.

20.4 Pressure monitor output signal (P_MONITOR)

The driver generates an analog output signal proportional to the actual pressure of the valve; the monitor output signal can be software set to show other signals available in the driver (e.g. analog reference, fieldbus reference).

Monitor output signal is factory preset according to selected valve code, defaults settings are 0 \div 10 Vdc for standard and 4 \div 20 mA for /I option.

Output signal can be reconfigured via software selecting between voltage and current, within a maximum range of 0 \div 10 Vdc or 0 \div 20 mA.

20.5 Enable input signal (ENABLE)

To enable the driver, supply a 24 VDC on pin 6: Enable input signal allows to enable/disable the current supply to the solenoid, without removing the electrical power supply to the driver; it is used to active the communication and the other driver functions when the valve must be disabled for safety reasons. This condition **does not comply** with norms IEC 61508 and ISO 13849.

Enable input signal can be used as generic digital input by software selection.

20.6 Fault output signal (FAULT)

Fault output signal indicates fault conditions of the driver (solenoid short circuits/not connected, reference signal cable broken for 4 \div 20 mA input, spool position transducer cable broken, etc.). Fault presence corresponds to 0 Vdc, normal working corresponds to 24 VDC.

Fault status is not affected by the Enable input signal. Fault output signal can be used as digital output by software selection.

21 TERMINAL BOARD OVERVIEW

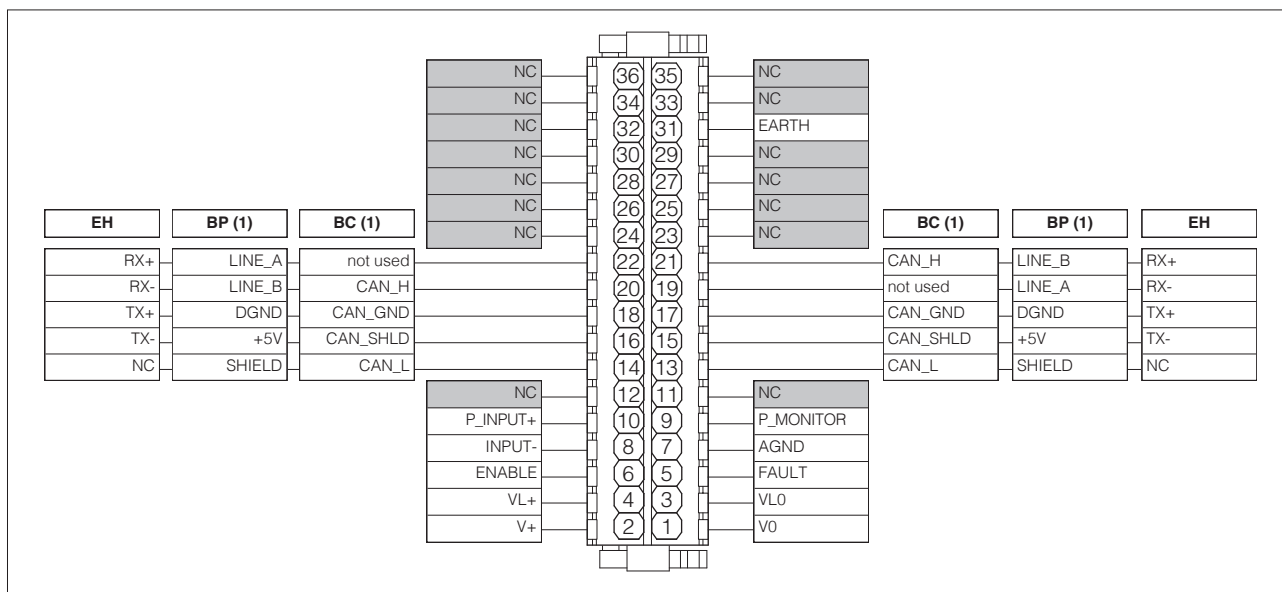

(1) For BC and BP executions the fieldbus connections have an internal pass-through connection

22 ELECTRONIC CONNECTIONS

22.1 Main connections signals

CABLE ENTRANCE	PIN	SIGNAL	TECHNICAL SPECIFICATIONS	NOTES
A	1	V0	Power supply 0 Vdc	Gnd - power supply
	2	V+	Power supply 24 Vdc	Input - power supply
	3	VL0	Power supply 0 Vdc for driver's logic and communication	Gnd - power supply
	4	VL+	Power supply 24 Vdc for driver's logic and communication	Input - power supply
	5	FAULT	Fault (0 Vdc) or normal working (24 Vdc), referred to VL0	Output - on/off signal
	6	ENABLE	Enable (24 Vdc) or disable (0 Vdc) the driver, referred to VL0	Input - on/off signal
	7	AGND	Analog ground	Gnd - analog signal
	8	INPUT-	Negative pressure reference input signal for INPUT+	Input - analog signal
	9	P_MONITOR	Pressure monitor output signal: 0 ÷ 10 Vdc / 0 ÷ 20 mA maximum range, referred to AGND Default is: 0 ÷ 10 Vdc or 4 ÷ 20 mA	Output - analog signal Software selectable
	10	P_INPUT+	Pressure reference input signal: ±10 Vdc / ±20 mA maximum range Defaults are: 0 ÷ 10 Vdc for standard and 4 ÷ 20 mA for /I option	Input - analog signal Software selectable
31	EARTH	Internally connected to driver housing		

22.2 USB connector - M12 - 5 pin always present

CABLE ENTRANCE	PIN	SIGNAL	TECHNICAL SPECIFICATIONS
B	1	+5V_USB	Power supply
	2	ID	Identification
	3	GND_USB	Signal zero data line
	4	D-	Data line -
	5	D+	Data line +

Driver view

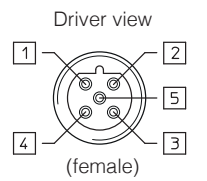

(female)

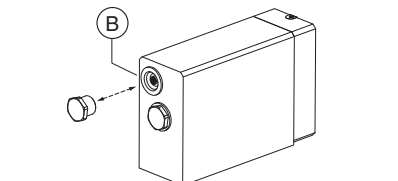

22.3 BC fieldbus execution connections

CABLE ENTRANCE	PIN	SIGNAL	TECHNICAL SPECIFICATIONS
C1	14	CAN_L	Bus line (low)
	16	CAN_SHLD	Shield
	18	CAN_GND	Signal zero data line
	20	CAN_H	Bus line (high)
	22	not used	Pass-through connection (1)

CABLE ENTRANCE	PIN	SIGNAL	TECHNICAL SPECIFICATIONS
C2	13	CAN_L	Bus line (low)
	15	CAN_SHLD	Shield
	17	CAN_GND	Signal zero data line
	19	not used	Pass-through connection (1)
	21	CAN_H	Bus line (high)

(1) Pin 19 and 22 can be fed with external +5V supply of CAN interface

22.4 BP fieldbus execution connections

CABLE ENTRANCE	PIN	SIGNAL	TECHNICAL SPECIFICATIONS
C1	14	SHIELD	
	16	+5V	Power supply
	18	DGND	Data line and termination signal zero
	20	LINE_B	Bus line (low)
	22	LINE_A	Bus line (high)

CABLE ENTRANCE	PIN	SIGNAL	TECHNICAL SPECIFICATIONS
C2	13	SHIELD	
	15	+5V	Power supply
	17	DGND	Data line and termination signal zero
	19	LINE_A	Bus line (high)
	21	LINE_B	Bus line (low)

22.5 EH fieldbus execution connections

CABLE ENTRANCE	PIN	SIGNAL	TECHNICAL SPECIFICATIONS
C1 (input)	14	NC	do not connect
	16	TX-	Transmitter
	18	TX+	Transmitter
	20	RX-	Receiver
	22	RX+	Receiver

CABLE ENTRANCE	PIN	SIGNAL	TECHNICAL SPECIFICATIONS
C2 (output)	13	NC	do not connect
	15	TX-	Transmitter
	17	TX+	Transmitter
	19	RX-	Receiver
	21	RX+	Receiver

CABLE ENTRANCE OVERVIEW

Cables entrance description:

- (A) main connections
- (B) USB connector always present (factory plugged)
- (C1) fieldbus interface (input)
- (C2) fieldbus interface (output)
- (P) threaded plug

PRESSURE TRANSDUCER CONNECTION
factory wired

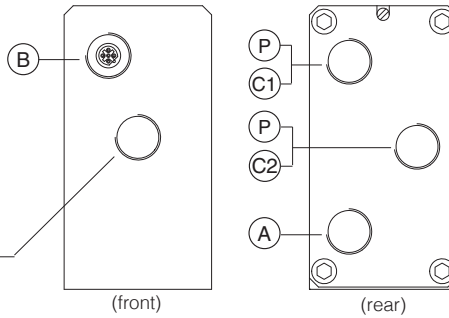

TERMINAL BOARD AND FIELDBUS TERMINATOR

Remove the 4 screws of driver's rear cover to access terminal board and fieldbus terminator

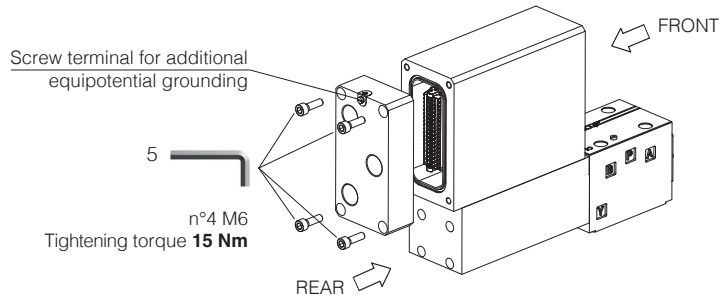

WARNING: the above operation must be performed in a safety area

Terminal board - see section 22

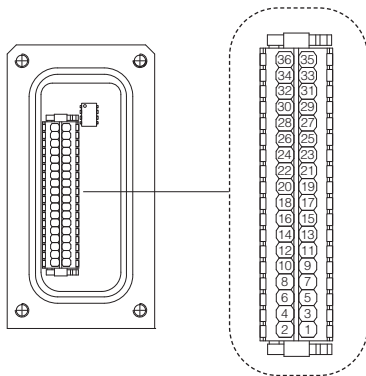

Fieldbus terminator only for BC and BP executions (1)

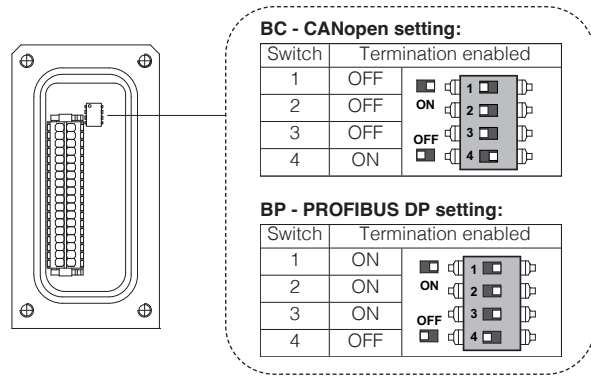

BLUETOOTH ADAPTER AND USB CONNECTOR

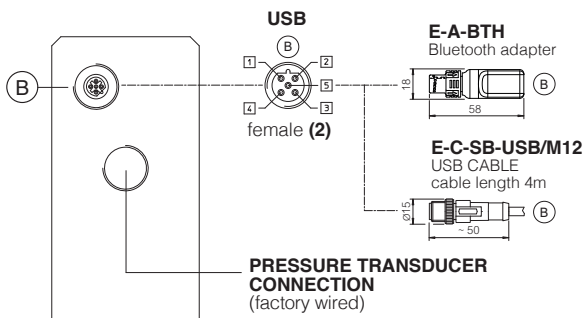

METALLIC PROTECTION CAP - supplied with the valves

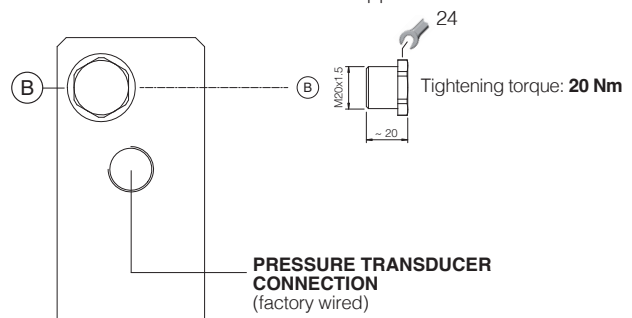

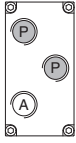
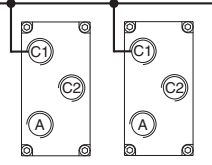
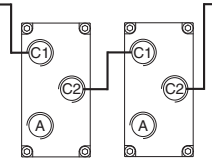

(1) Drivers with BC and BP fieldbus interface are delivered by default 'Not Terminated'. All switches are set OFF
 (2) Pin layout always referred to driver's view

23.1 Cable glands and threaded plug - see tech table **KX800**

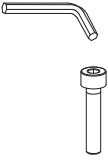

Communication interfaces	To be ordered separately				Cable entrance overview	Notes
	Cable gland quantity	entrance	Threaded plug quantity	entrance		
NP	1	A	none	none		Cable entrance P are factory plugged Cable entrance A is open for costumers
BC, BP, EH "via stub" connection	2	C1 A	1	C2		Cable entrance A, C1, C2 are open for costumers
BC, BP, EH "daisy chain" connection	3	C1 C2 A	none	none		Cable entrance A, C1, C2 are open for costumers

24 FASTENING BOLTS AND SEALS

24.1 RZGA valves

	RZGA-RES*-010	RZGA-RES*-033
	<p>Fastening bolts: 4 socket head screws M5x50 class 12.9 Tightening torque = 8 Nm</p>	<p>Fastening bolts: 4 socket head screws M5x50 class 12.9 Tightening torque = 8 Nm</p>
	<p>Seals: 4 OR 108 Diameter of ports P, A, T: Ø 5 mm</p>	<p>Seals: 4 OR 108 Diameter of ports P, A, T: Ø 7,5 mm</p>

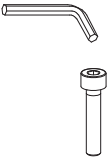
24.2 AGRCZA valves

	AGRCZA-RES*-10	AGRCZA-RES*-20
	<p>Fastening bolts: 4 socket head screws M10x45 class 12.9 Tightening torque = 70 Nm</p>	<p>Fastening bolts: 4 socket head screws M10x45 class 12.9 Tightening torque = 70 Nm</p>
	<p>Seals: 2 OR 3068 Diameter of ports A, B: Ø 14 mm 2 OR 109/70 Diameter of port X, Y: Ø 5 mm</p>	<p>Seals: 2 OR 4100 Diameter of ports A, B: Ø 22 mm 2 OR 109/70 Diameter of port X, Y: Ø 5 mm</p>

RZGA-RES-*-010

ISO 4401: 2005

Mounting surface: 4401-03-02-0-05 (see table P005)
(port B not used)

Mass [kg]	
RZGA-RES-*-010	8,5

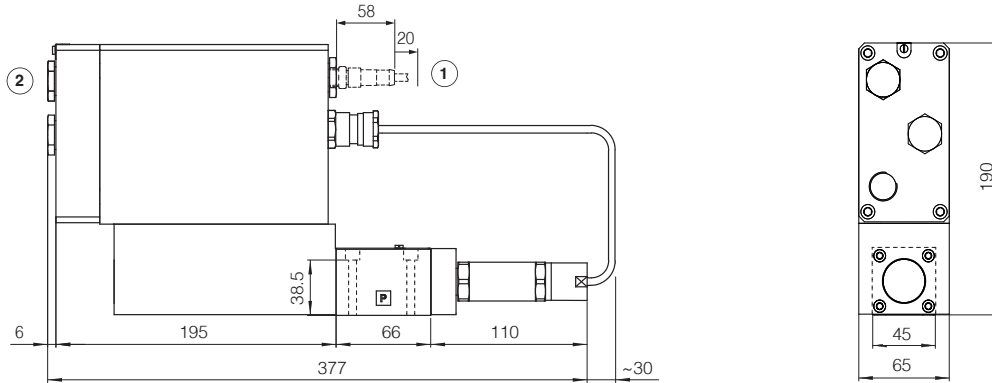

RZGA-RES-*-033

ISO 4401: 2005

Mounting surface: 4401-03-02-0-05 (see table P005)
(port B not used)

Mass [kg]	
RZGA-RES-*-033	9,5

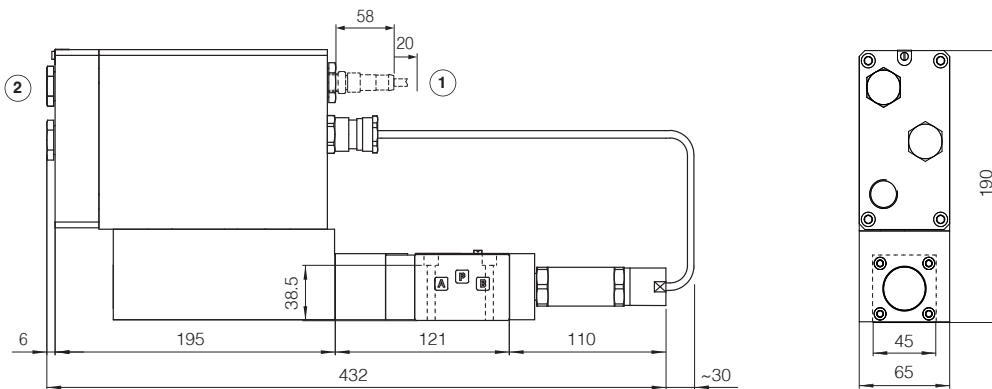

① = Space required for connection cable and for Bluetooth adapter or USB connector removal

② = The dimensions of cable glands must be considered (see tech table **KX800**)

AGRCZA-RES-*-10

ISO 5781: 2000

Mounting surface: 5781-06-07-0-00 (see table P005)

Mass [kg]	
AGRCZA-RES-*-10	12,1

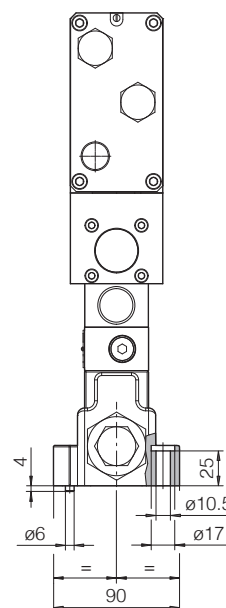
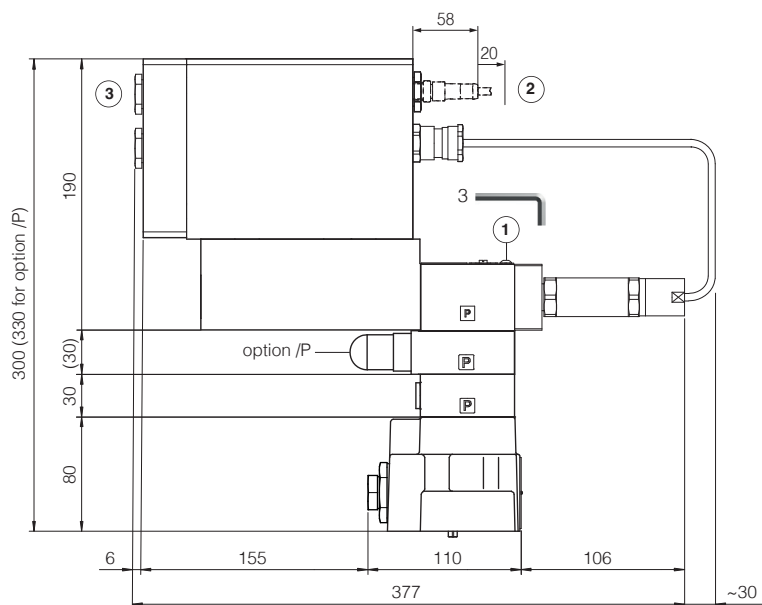

AGRCZA-RES-*-20

ISO 5781: 2000

Mounting surface: 5781-08-10-0-00 (see table P005)

Mass [kg]	
AGRCZA-RES-*-20	13,3

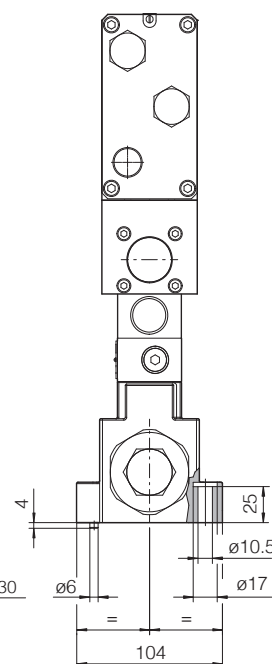
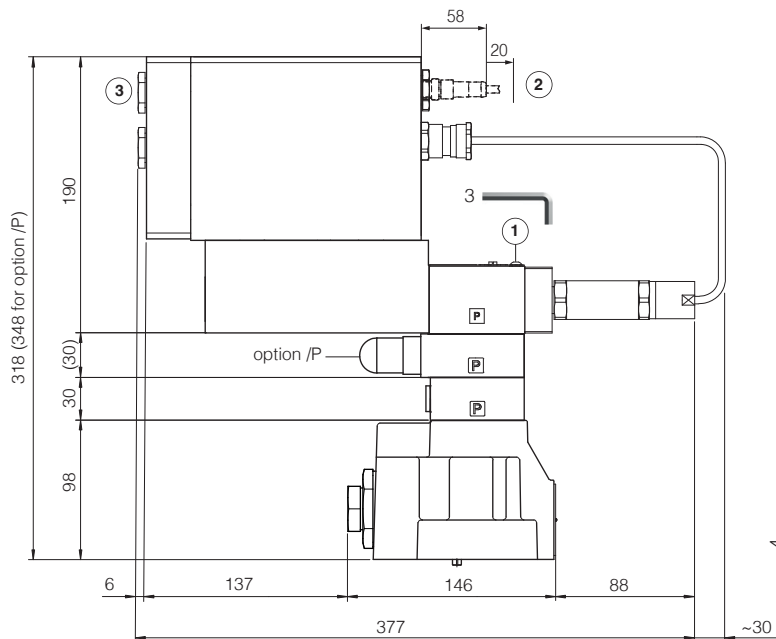

- ① = Air bleeding
- ② = Space required for connection cable and for Bluetooth adapter or USB connector removal
- ③ = The dimensions of cable glands must be considered (see tech table **KX800**)

27 RELATED DOCUMENTATION

- X010** Basics for electrohydraulics in hazardous environments
- X020** Summary of Atos ex-proof components certified to ATEX, IECEx, EAC, PESO, CCC
- FX900** Operating and maintenance information for ex-proof proportional valves
- GS500** Programming tools
- GS510** Fieldbus

- GX800** Ex-proof pressure transducer type E-ATRA-7
- KX800** Cable glands for ex-proof valves
- P005** Mounting surfaces for electrohydraulic valves
- E-MAN-RA-RES** RES user manual