

Ex-proof digital proportional 2-way cartridges high performance

piloted, with on-board driver and two LVDT transducers - **ATEX, IECEx, EAC, CCC**

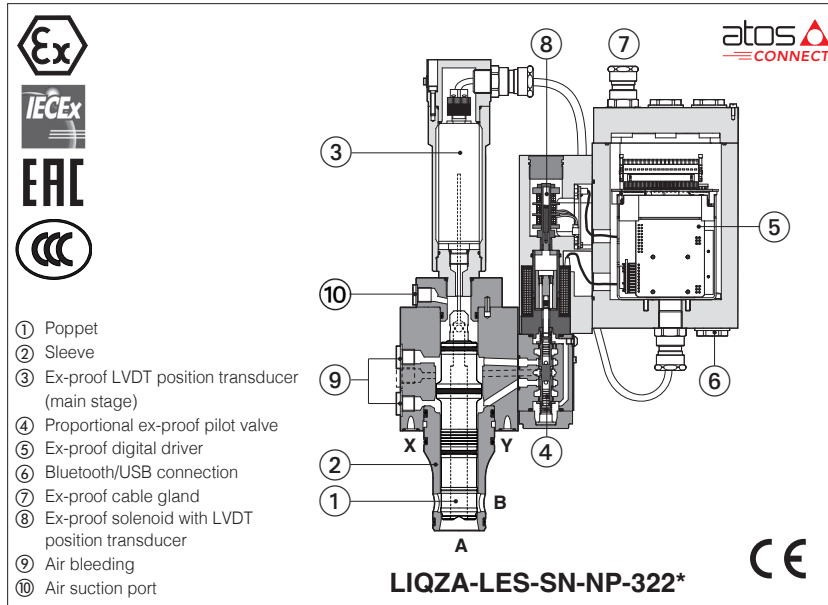

- ① Poppet
- ② Sleeve
- ③ Ex-proof LVDT position transducer (main stage)
- ④ Proportional ex-proof pilot valve
- ⑤ Ex-proof digital driver
- ⑥ Bluetooth/USB connection
- ⑦ Ex-proof cable gland
- ⑧ Ex-proof solenoid with LVDT position transducer
- ⑨ Air bleeding
- ⑩ Air suction port

LIQZA-LES

Ex-proof digital proportional 2-way cartridges, high performance with two LVDT position transducers (pilot valve and main stage) for best accuracy in not compensated flow regulations.

They are equipped with ex-proof on-board digital driver, LVDT transducers and proportional solenoid certified for safe operations in hazardous environments with potentially explosive atmosphere.

- Multicertification **ATEX, IECEx, EAC** and **CCC** for gas group **II 2G** and dust category **II 2D**

The flameproof enclosure of on-board digital driver, solenoid and transducers, prevents the propagation of accidental internal sparks or fire to the external environment.

The driver and solenoid are also designed to limit the surface temperature within the classified limits.

Size: **25 ÷ 100** - ISO 7368
 Max flow: **1200 ÷ 16000** l/min
 Max pressure: **420 bar**

1 MODEL CODE

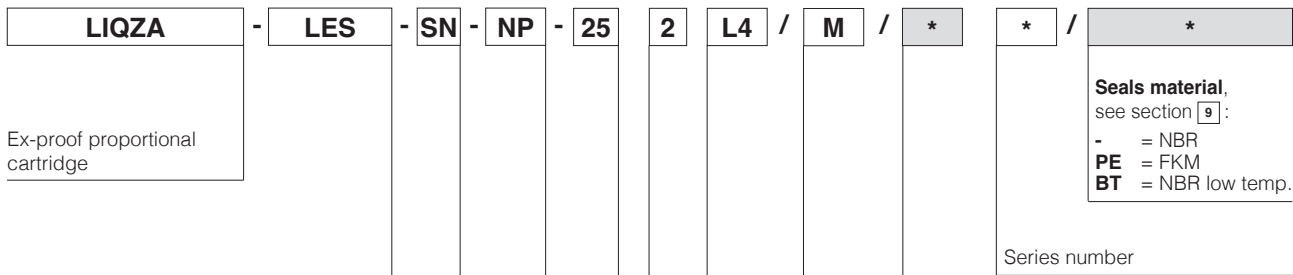

Valve size and nominal flow (l/min) at Δp 5 bar:

- 25=500
- 32=800
- 40=1200
- 50=2000
- 63=3000
- 80=4500
- 100=7200

Configuration: **2 = 2 way**

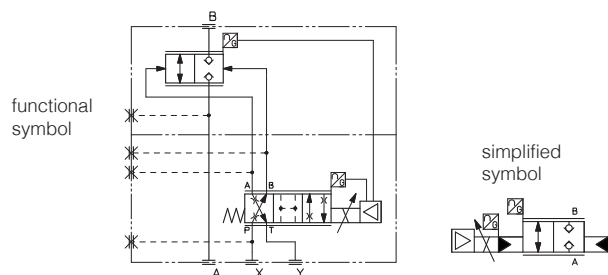

2 GENERAL NOTES

Atos digital proportional valves are CE marked according to the applicable directives (e.g. Immunity and Emission EMC Directive). Installation, wirings and start-up procedures must be performed according to the general prescriptions shown in tech table **FX900** and in the user manuals included in the E-SW-SETUP programming software.

3 VALVE SETTINGS AND PROGRAMMING TOOLS - see tech. table **GS500**

WARNING: the below operation must be performed in a safety area!

3.1 Atos CONNECT mobile App

Free downloadable App for smartphones and tablets which allows quick access to valve main functional parameters and basic diagnostic information via Bluetooth, thus avoiding physical cable connection and significantly reducing commissioning time. Atos CONNECT supports Atos digital valve drivers equipped with E-A-BTH adapter or with built-in Bluetooth. It does not support valves with p/Q control or axis controls.



3.2 E-SW-SETUP PC software

Free downloadable software for PC allows to set all valve functional parameters and to access complete diagnostic information of digital valve drivers via Bluetooth/USB service port. Atos E-SW-SETUP PC software supports all Atos digital valve drivers and it is available at www.atos.com in MyAtos area.

WARNING: drivers USB port is not isolated! For E-C-SB-USB/M12 cable, the use of E-A-SB-USB/OPT isolator adapter is highly recommended for PC protection

WARNING: for the list of countries where the Bluetooth adapter has been approved, see tech. table **GS500**

Bluetooth or USB connection

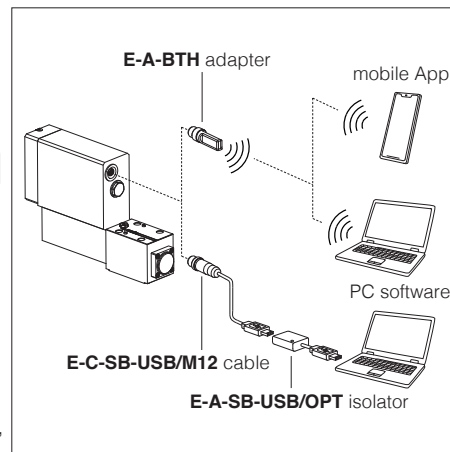

4 FIELDBUS - see tech. table **GS510**

Fieldbus allows valve direct communication with machine control unit for digital reference, valve diagnostics and settings. These executions allow to operate the valves through fieldbus or analog signals available on the terminal board.

5 GENERAL CHARACTERISTICS

Assembly position	Any position
Subplate surface finishing to ISO 4401	Acceptable roughness index, Ra ≤0,8 recommended Ra 0,4 - flatness ratio 0,01/100
MTTFd values according to EN ISO 13849	75 years, for further details see technical table P007
Ambient temperature range	Standard = -20°C ÷ +60°C /PE option = -20°C ÷ +60°C /BT option = -40°C ÷ +60°C
Storage temperature range	Standard = -20°C ÷ +70°C /PE option = -20°C ÷ +70°C /BT option = -40°C ÷ +70°C
Surface protection	Zinc coating with black passivation
Corrosion resistance	Salt spray test (ISO 9227) > 200 h
Vibration resistance	See technical table GX004
Compliance	Explosion proof protection, see section 8 -Flame proof enclosure "Ex d" -Dust ignition protection by enclosure "Ex t" RoHs Directive 2011/65/EU as last update by 2015/863/EU REACH Regulation (EC) n°1907/2006

6 HYDRAULIC CHARACTERISTICS - based on mineral oil ISO VG 46 at 50 °C

Size	25	32	40	50	63	80	100
Max regulated flow [l/min]							
Δp A-B at Δp = 5 bar	500	800	1200	2000	3000	4500	7200
at Δp = 10 bar	700	1100	1700	2800	4250	6350	10200
Max permissible flow	1200	1800	2500	4000	6000	10000	16000
Max pressure [bar]	Ports A, B = 420 X = 350 Y ≤ 10						
Nominal flow of pilot valve at Δp = 70 bar [l/min]	8	20	40	40	100	100	100
Leakage of pilot valve at P = 100 bar [l/min]	0,2	0,3	0,7	0,7	1	1	1
Piloting pressure [bar]	min: 40% of system pressure max 350 recommended 140 ÷ 160						
Piloting volume [cm³]	2,2	7,0	9,4	17,7	32,5	39,5	49,5
Piloting flow (1) [l/min]	5,3	14	19	35,5	56	60	60
Response time 0 ÷ 100% step signal (2) [ms]	≤ 30	≤ 32	≤ 35	≤ 35	≤ 40	≤ 45	≤ 55
Hysteresis [% of the max regulation]	≤ 0,1						
Repeatability [% of the max regulation]	± 0,1						
Thermal drift	zero point displacement < 1% at ΔT = 40°C						

(1) 0÷100% step signal

(2) With pilot pressure = 140 bar

7 ELECTRICAL CHARACTERISTICS

Power supplies	Nominal : +24 VDC Rectified and filtered : VRMS = 20 ÷ 32 VMAX (ripple max 10 % VPP)			
Max power consumption	35 W			
Analog input signals	Voltage: range ±10 VDC (24 VMAX tolerant) Current: range ±20 mA		Input impedance: Ri > 50 kΩ Input impedance: Ri = 500 Ω	
Insulation class	H (180°) Due to the occurring surface temperatures of the solenoid coils, the European standards ISO 13732-1 and EN982 must be taken into account			
Monitor outputs	Output range: voltage ±10 Vdc @ max 5 mA current ±20 mA @ max 500 Ω load resistance			
Enable input	Range: 0 ÷ 5 Vdc (OFF state), 9 ÷ 24 Vdc (ON state), 5 ÷ 9 Vdc (not accepted); Input impedance: Ri > 10 kΩ			
Fault output	Output range: 0 ÷ 24 Vdc (ON state > [power supply - 2 V] ; OFF state < 1 V) @ max 50 mA; external negative voltage not allowed (e.g. due to inductive loads)			
Alarms	Solenoid not connected/short circuit, cable break with current reference signal, over/under temperature, valve spool transducer malfunctions			
Protection degree to DIN EN60529	IP66/67 with relevant cable gland			
Duty factor	Continuous rating (ED=100%)			
Tropicalization	Tropical coating on electronics PCB			
Additional characteristics	Short circuit protection of solenoid current supply; spool position control by P.I.D. with rapid solenoid switching; protection against reverse polarity of power supply			
Electromagnetic compatibility (EMC)	According to Directive 2014/30/UE (Immunity: EN 61000-6-2; Emission: EN 61000-6-3)			
Communication interface	USB Atos ASCII coding	CANopen EN50325-4 + DS408	PROFIBUS DP EN50170-2/IEC61158	EtherCAT, POWERLINK, EtherNet/IP, PROFINET IO RT / IRT EC 61158
Communication physical layer	not insulated USB 2.0 + USB OTG	optical insulated CAN ISO11898	optical insulated RS485	Fast Ethernet, insulated 100 Base TX

Note: a maximum time of 800 ms (depending on communication type) has to be considered between the driver energizing with the 24 VDC power supply and when the valve is ready to operate. During this time the current to the valve coils is switched to zero

8 CERTIFICATION DATA

Components type	Pilot valve solenoid and LVDT transducer			LVDT main stage transducer
Certifications	Multicertification Group II ATEX IECEX EAC CCC			
Components Certified code	OZA-LES			ETHA-15
Type examination certificate (1)	ATEX: TUV IT 18 ATEX 068 X IECEX: IECEX TPS 19.0004X EAC:RU C - IT.AX38.B.00425/21 CCC: 2024322307006321			ATEX: TUV IT 16 ATEX 053 X IECEX: IECEX TPS 16.0003X EAC:RU C-IT.AX38.B.00425/21 CCC: 2024322315006312
Method of protection	<ul style="list-style-type: none"> • ATEX Ex II 2G Ex db IIC T6/T5/T4 Gb Ex II 2D Ex tb IIIC T85°C/T100°C/T135°C Db • IECEX, CCC Ex db IIC T6/T5/T4 Gb Ex tb IIIC T85°C/T100°C/T135°C Db • EAC: 1Ex d IIC T6/T5/T4 Gb Ex tb IIIC T85°C/T100°C/T135°C Db X 			<ul style="list-style-type: none"> • ATEX Ex II 2G Ex db IIC T6 Gb Ex II 2D Ex tb IIIC T85°C Db Ex I M2 Ex db IMb • IECEX Ex db IIC T6 Gb Ex tb IIIC T85°C Db Ex db IMb • EAC: 1Ex d IIC T4/T3 Gb X Ex tb IIIC T135°C/T200°C Db X • CCC Ex db IIC T6 Gb Ex tb IIIC T85°C Db
Temperature class	T6	T5	T4	T6
Surface temperature	≤ 85 °C	≤ 100 °C	≤ 135 °C	≤ 85 °C
Ambient temperature (2)	-40 ÷ +40 °C	-40 ÷ +55 °C	-40 ÷ +70 °C	-40 ÷ +70 °C
Applicable Standards	EN 60079-0 EN 60079-1	EN 60079-31	IEC 60079-0 IEC 60079-1	IEC 60079-31
Cable entrance: threaded connection	M = M20x1,5			factory wired

(1) The type examiner certificates can be downloaded from www.atos.com

(2) The driver solenoid and LVDT transducers are certified for minimum ambient temperature -40°C.

In case the complete valve must withstand with minimum ambient temperature -40°C, select **/BT** in the model code.

⚠ WARNING: service work performed on the valve by the end users or not qualified personnel invalidates the certification

9 SEALS AND HYDRAULIC FLUIDS - for other fluids not included in below table, consult our technical office

Seals, recommended fluid temperature	NBR seals (standard) = -20°C ÷ +60°C, with HFC hydraulic fluids = -20°C ÷ +50°C FKM seals (/PE option) = -20°C ÷ +80°C NBR low temp. seals (/BT option) = -40°C ÷ +60°C, with HFC hydraulic fluids = -20°C ÷ +50°C		
Recommended viscosity	20 ÷ 100 mm ² /s - max allowed range 15 ÷ 380 mm ² /s		
Max fluid contamination level	normal operation	ISO4406 class 18/16/13 NAS1638 class 7	see also filter section at www.atos.com or KTF catalog
	longer life	ISO4406 class 16/14/11 NAS1638 class 5	
Hydraulic fluid	Suitable seals type	Classification	Ref. Standard
Mineral oils	NBR, FKM, NBR low temp.	HL, HLP, HLPD, HVLP, HVLPD	DIN 51524
Flame resistant without water	FKM	HFDU, HFDR	ISO 12922
Flame resistant with water (1)	NBR, NBR low temp.	HFC	

! The ignition temperature of the hydraulic fluid must be 50°C higher than the max solenoid surface temperature

(1) Performance limitations in case of flame resistant fluids with water:

- max operating pressure = 210 bar
- max fluid temperature = 50°C

10 CABLE SPECIFICATION AND TEMPERATURE - Power supply and grounding cables have to comply with following characteristics:

Power supply and signals: section of wire = 1,0 mm ²	Grounding: section of external ground wire = 4 mm ²
--	---

10.1 Cable temperature

The cable must be suitable for the working temperature as specified in the "safety instructions" delivered with the first supply of the products.

Max ambient temperature [°C]	Temperature class	Max surface temperature [°C]	Min. cable temperature [°C]
40 °C	T6	85 °C	80 °C
55 °C	T5	100 °C	90 °C
70 °C	T4	135 °C	110 °C

11 CABLE GLANDS

Cable glands with threaded connections M20x1,5 for standard or armoured cables have to be ordered separately, see tech table **KX800**

Note: a Loctite sealant type 545, should be used on the cable gland entry threads

12 DIAGRAMS (based on mineral oil ISO VG 46 at 50 °C)

12.1 Regulation diagrams (values measured at Δp 5 bar)

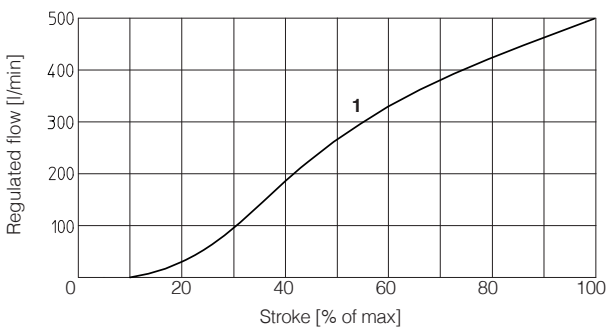

1 = LIQZA-LES-25*

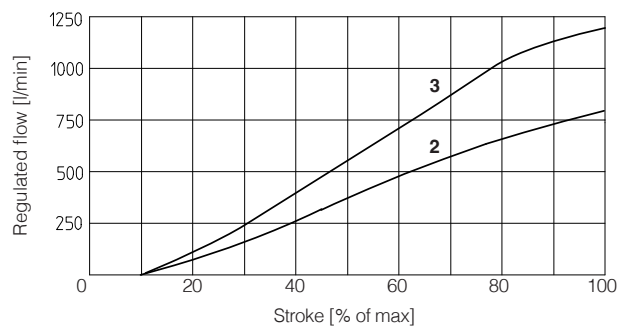

2 = LIQZA-LES-32* **3** = LIQZA-LES-40*

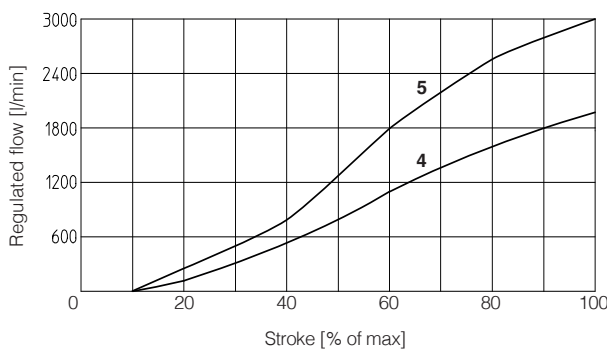

4 = LIQZA-LES-50* **5** = LIQZA-LES-63*

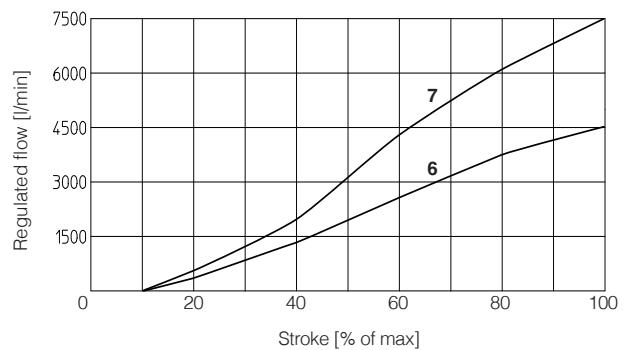

6 = LIQZA-LES-80* **7** = LIQZA-LES-100*

13 ELECTRONIC OPTIONS

- I = It provides 4 ÷ 20 mA current reference signal, instead of the standard 0 ÷ 10 Vdc.
Input signal can be reconfigured via software selecting between voltage and current, within a maximum range of ±10 VDC or ±20 mA
It is normally used in case of long distance between the machine control unit and the valve or where the reference signal can be affected by electrical noise; the valve functioning is disabled in case of reference signal cable breakage.

14 POWER SUPPLY AND SIGNALS SPECIFICATIONS

Generic electrical output signals of the valve (e.g. fault or monitor signals) must not be directly used to activate safety functions, like to switch-ON/OFF the machine's safety components, as prescribed by the European standards (Safety requirements of fluid technology systems and components-hydraulics, ISO 4413).

14.1 Power supply (V+ and V0)

The power supply must be appropriately stabilized or rectified and filtered: apply at least a 10000 µF/40 V capacitance to single phase rectifiers or a 4700 µF/40 V capacitance to three phase rectifiers.

 A safety fuse is required in series to each power supply: 2,5 A time lag fuse.

14.2 Power supply for driver's logic and communication (VL+ and VL0)

The power supply for driver's logic and communication must be appropriately stabilized or rectified and filtered: apply at least a 10000 µF/40 V capacitance to single phase rectifiers or a 4700 µF/40 V capacitance to three phase rectifiers.

The separate power supply for driver's logic on pin 3 and 4, allow to remove solenoid power supply from pin 1 and 2 maintaining active the diagnostics, USB and fieldbus communications.

 A safety fuse is required in series to each driver's logic and communication power supply: 500 mA fast fuse.

14.3 Flow reference input signal (Q_INPUT+)

The driver controls in closed loop the valve spool position proportionally to the external reference input signal.

Reference input signal is factory preset according to selected valve code, defaults are 0 ÷ 10 VDC for standard and 4 ÷ 20 mA for /I option.

Input signal can be reconfigured via software selecting between voltage and current, within a maximum range of ±10 VDC or ± 20 mA.

Drivers with fieldbus interface can be software set to receive reference signal directly from the machine control unit (fieldbus reference). Analog reference input signal can be used as on-off commands with input range 0 ÷ 24VDC.

14.4 Flow monitor output signal (Q_MONITOR)

The driver generates an analog output signal proportional to the actual spool position of the valve; the monitor output signal can be software set to show other signals available in the driver (e.g. analog reference, fieldbus reference, pilot spool position).

Monitor output signal is factory preset according to selected valve code, defaults are 0 ÷ 10 VDC for standard and 4 ÷ 20 mA for /I option.

Output signal can be reconfigured via software selecting between voltage and current, within a maximum range of ±10 VDC or ± 20 mA.

14.5 Enable input signal (ENABLE)

To enable the driver, supply a 24 VDC on pin 6: Enable input signal allows to enable/disable the current supply to the solenoid, without removing the electrical power supply to the driver; it is used to active the communication and the other driver functions when the valve must be disabled for safety reasons. This condition **does not comply** with norms IEC 61508 and ISO 13849.

Enable input signal can be used as generic digital input by software selection.

14.6 Fault output signal (FAULT)

Fault output signal indicates fault conditions of the driver (solenoid short circuits/not connected, reference signal cable broken for 4 ÷ 20 mA input, spool position transducer cable broken, etc.). Fault presence corresponds to 0 VDC, normal working corresponds to 24 VDC.

Fault status is not affected by the Enable input signal. Fault output signal can be used as digital output by software selection.

15 TERMINAL BOARD OVERVIEW

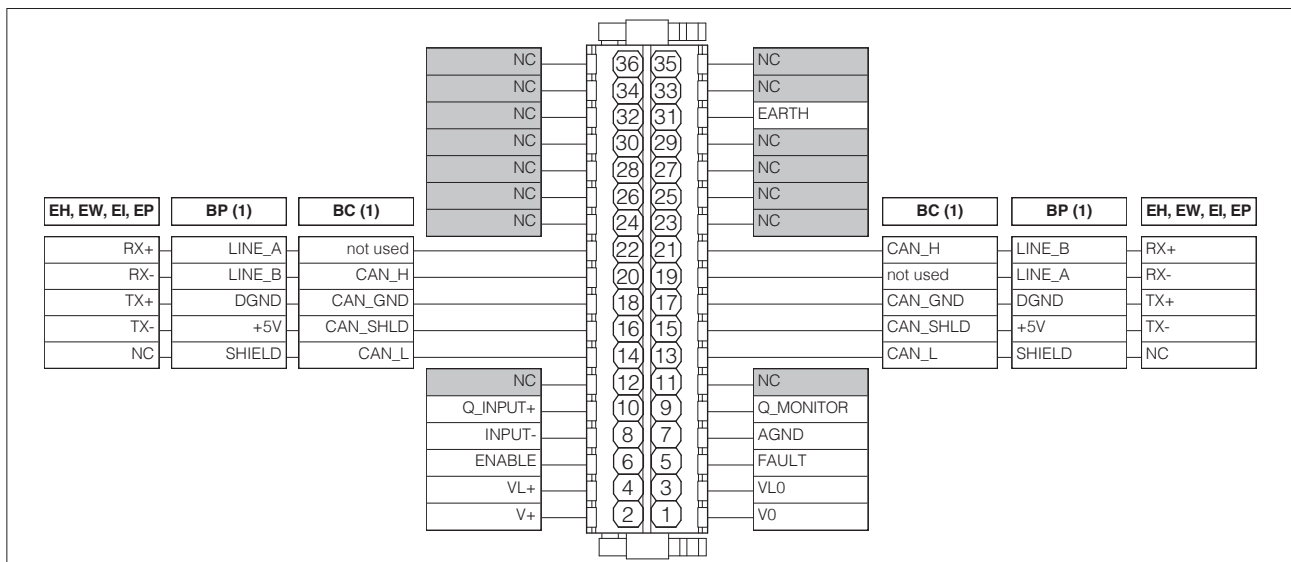

(1) For BC and BP executions the fieldbus connections have an internal pass-through connection

16 ELECTRONIC CONNECTIONS

16.1 Main connections signals

CABLE ENTRANCE	PIN	SIGNAL	TECHNICAL SPECIFICATIONS	NOTES
A	1	V0	Power supply 0 Vdc	Gnd - power supply
	2	V+	Power supply 24 Vdc	Input - power supply
	3	VL0	Power supply 0 Vdc for driver's logic and communication	Gnd - power supply
	4	VL+	Power supply 24 Vdc for driver's logic and communication	Input - power supply
	5	FAULT	Fault (0 Vdc) or normal working (24 Vdc), referred to VL0	Output - on/off signal
	6	ENABLE	Enable (24 Vdc) or disable (0 Vdc) the driver, referred to VL0	Input - on/off signal
	7	AGND	Analog ground	Gnd - analog signal
	8	INPUT-	Negative reference input signal for INPUT+	Input - analog signal
	9	Q_MONITOR	Flow monitor output signal: ± 10 Vdc / ± 20 mA maximum range, referred to AGND Defaults are: 0 ÷ 10 Vdc for standard and 4 ÷ 20 mA for /I option	Output - analog signal Software selectable
	10	Q_INPUT+	Flow reference input signal: ± 10 Vdc / ± 20 mA maximum range Defaults are: 0 ÷ 10 Vdc for standard and 4 ÷ 20 mA for /I option	Input - analog signal Software selectable
	31	EARTH	Internally connected to driver housing	

16.2 USB connector - M12 - 5 pin always present

CABLE ENTRANCE	PIN	SIGNAL	TECHNICAL SPECIFICATIONS		
B	1	+5V_USB	Power supply	<p>Driver view (female)</p>	
	2	ID	Identification		
	3	GND_USB	Signal zero data line		
	4	D-	Data line -		
	5	D+	Data line +		

16.3 BC fieldbus execution connections

CABLE ENTRANCE	PIN	SIGNAL	TECHNICAL SPECIFICATIONS
C1	14	CAN_L	Bus line (low)
	16	CAN_SHLD	Shield
	18	CAN_GND	Signal zero data line
	20	CAN_H	Bus line (high)
	22	not used	Pass-through connection (1)

CABLE ENTRANCE	PIN	SIGNAL	TECHNICAL SPECIFICATIONS
C2	13	CAN_L	Bus line (low)
	15	CAN_SHLD	Shield
	17	CAN_GND	Signal zero data line
	19	not used	Pass-through connection (1)
	21	CAN_H	Bus line (high)

(1) Pin 19 and 22 can be fed with external +5V supply of CAN interface

16.4 BP fieldbus execution connections

CABLE ENTRANCE	PIN	SIGNAL	TECHNICAL SPECIFICATIONS
C1	14	SHIELD	
	16	+5V	Power supply
	18	DGND	Data line and termination signal zero
	20	LINE_B	Bus line (low)
	22	LINE_A	Bus line (high)

CABLE ENTRANCE	PIN	SIGNAL	TECHNICAL SPECIFICATIONS
C2	13	SHIELD	
	15	+5V	Power supply
	17	DGND	Data line and termination signal zero
	19	LINE_A	Bus line (high)
	21	LINE_B	Bus line (low)

16.5 EH, EW, EI, EP fieldbus execution connections

CABLE ENTRANCE	PIN	SIGNAL	TECHNICAL SPECIFICATIONS
C1 (input)	14	NC	do not connect
	16	TX-	Transmitter
	18	TX+	Transmitter
	20	RX-	Receiver
	22	RX+	Receiver

CABLE ENTRANCE	PIN	SIGNAL	TECHNICAL SPECIFICATIONS
C2 (output)	13	NC	do not connect
	15	TX-	Transmitter
	17	TX+	Transmitter
	19	RX-	Receiver
	21	RX+	Receiver

17 CONNECTIONS LAYOUT

CABLE ENTRANCE OVERVIEW

Cables entrance description:

- (A) main connections
- (B) USB connector always present (factory plugged)
- (C1) fieldbus (input)
- (C2) fieldbus (output)
- (P) threaded plug

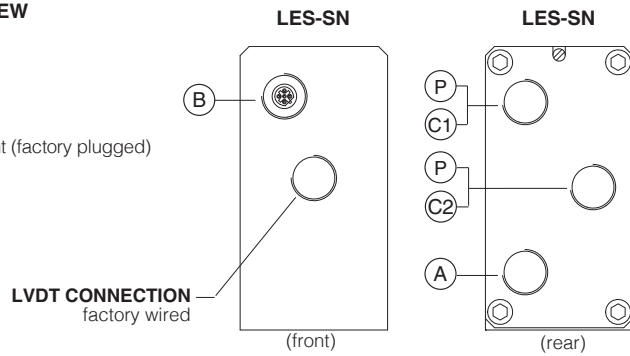

TERMINAL BOARD AND FIELDBUS TERMINATOR

Remove the 4 screws of driver's rear cover to access terminal board and fieldbus terminator

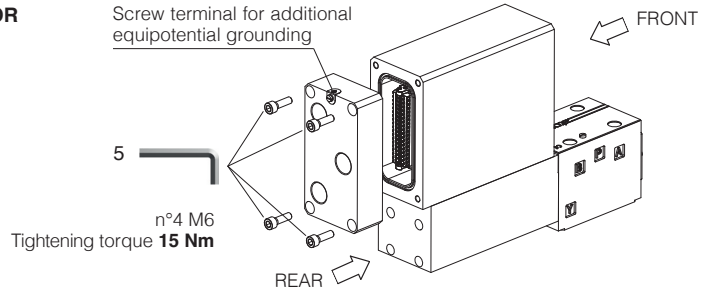

WARNING: the above operation must be performed in a safety area

Terminal board - see section 15

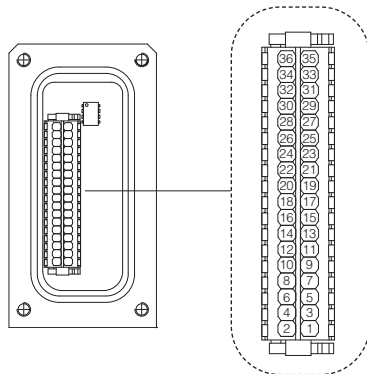

Fieldbus terminator only for BC and BP executions (1)

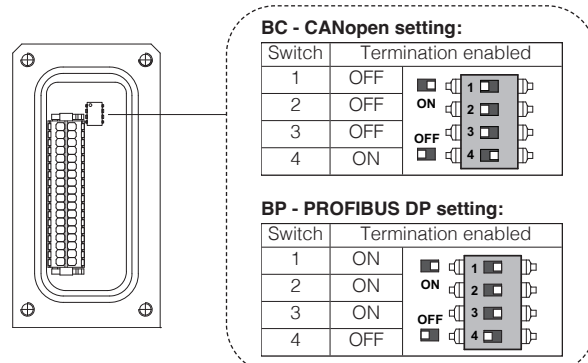

BLUETOOTH ADAPTER AND USB CONNECTOR

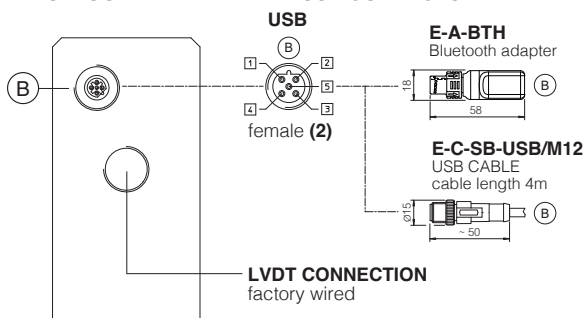

METALLIC PROTECTION CAP - supplied with the valves

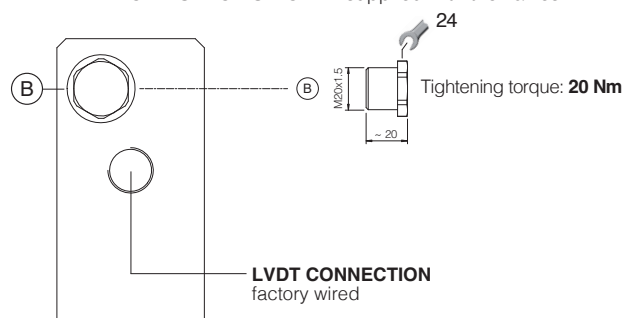

(1) Drivers with BC and BP fieldbus interface are delivered by default 'Not Terminated'. All switches are set OFF
 (2) Pin layout always referred to driver's view

17.1 Cable glands and threaded plug - see tech table **KX800**

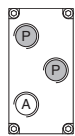
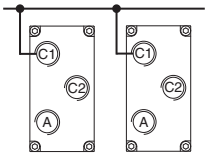
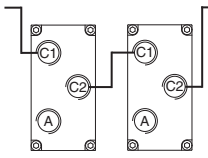
Communication interfaces	To be ordered separately				Cable entrance overview	Notes
	Cable gland quantity	entrance	Threaded plug quantity	entrance		
NP	1	A	none	none		Cable entrance A is open for costumers Cable entrance P are factory plugged
BC, BP, EH, EW, EI, EP "via stub" connection	2	C1 A	1	C2		Cable entrance A, C1, C2 are open for costumers
BC, BP, EH, EW, EI, EP "daisy chain" connection	3	C1 C2 A	none	none		Cable entrance A, C1, C2 are open for costumers

18 AIR BLEEDING

Size 25

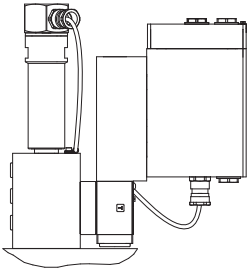

Sizes 32, 40, 50

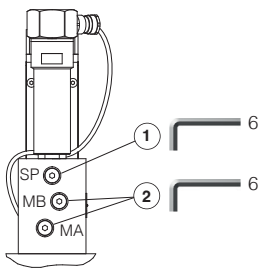

Sizes 63 to 100

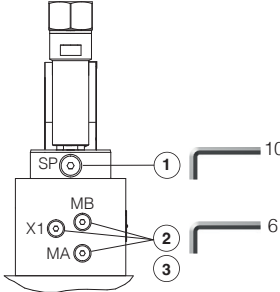

1 Air suction port (SP):
 N° 1 plug G1/4" for sizes 25 to 50
 N° 1 plug G1/2" for sizes 63 to 100
 To be used only in case port A is connected to tank and subjected to negative pressure, consult our technical office.

2 Air bleeding (MA, MB):
 N° 2 plugs G1/4"
 At the machine commissioning it is advisable to bleed the air from piloting chambers, by loosening the 2 plugs shown in the picture.
 Operate the valve for few seconds at low pressure and then lock the plugs.

3 External pilot pressure (X1):
 N° 1 plug G1/4" for sizes 32 to 100

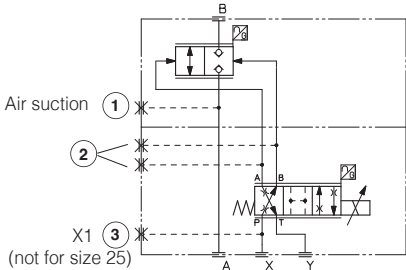

19 FASTENING BOLTS AND VALVE MASS

Type	Size	Fastening bolts (supplied with the valve)	Mass [kg]
LIQZA	25	4 socket head screws M12x100 class 12.9 Tightening torque = 125 Nm	15,2
	32	4 socket head screws M16x60 class 12.9 Tightening torque = 300 Nm	18
	40	4 socket head screws M20x70 class 12.9 Tightening torque = 600 Nm	23,7
	50	4 socket head screws M20x80 class 12.9 Tightening torque = 600 Nm	31
	63	4 socket head screws M30x120 class 12.9 Tightening torque = 2100 Nm	51
	80	8 socket head screws M24x80 class 12.9 Tightening torque = 1000 Nm	78,6
	100	8 socket head screws M30x120 class 12.9 Tightening torque = 2100 Nm	130

20 INSTALLATION DIMENSIONS [mm]

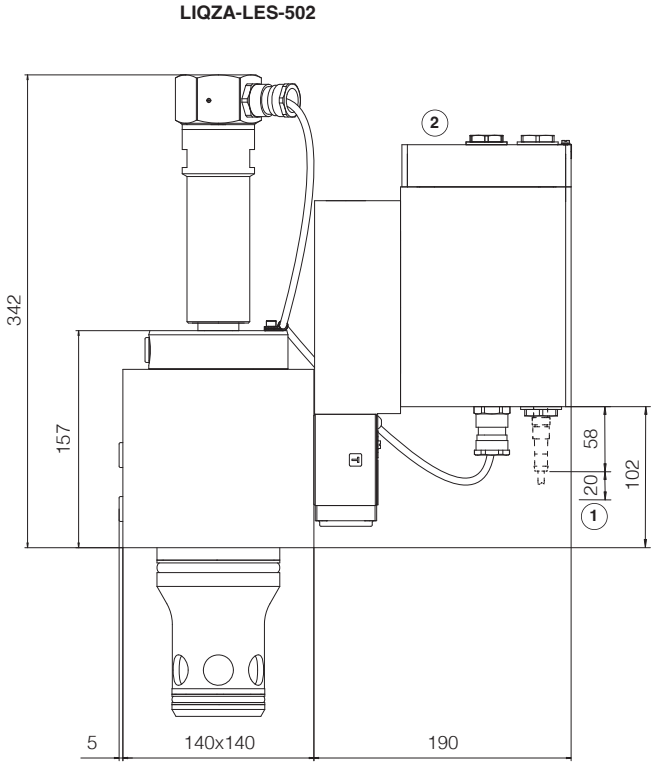
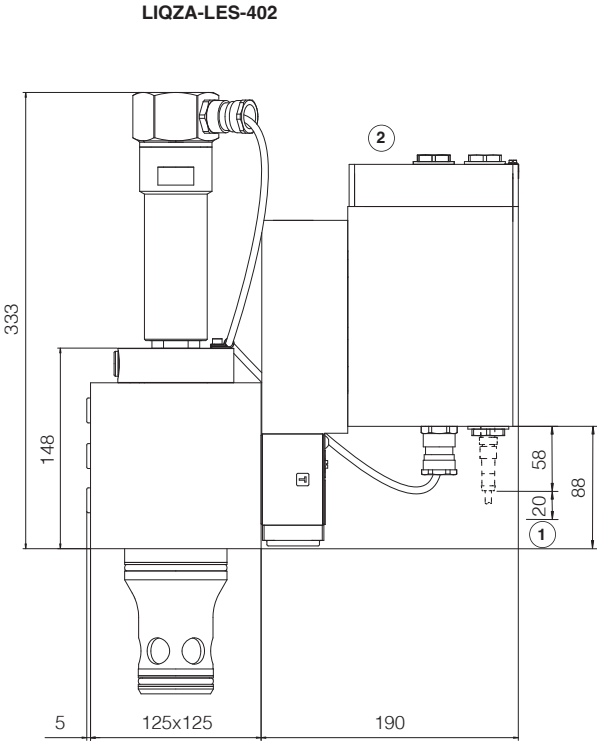
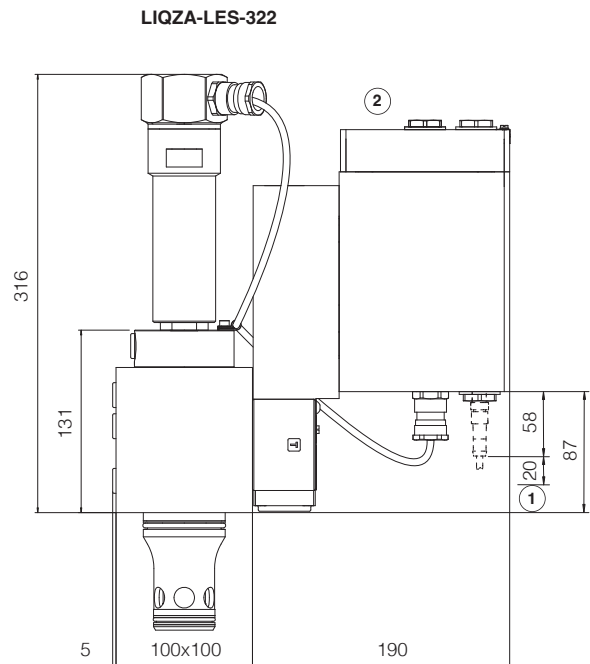
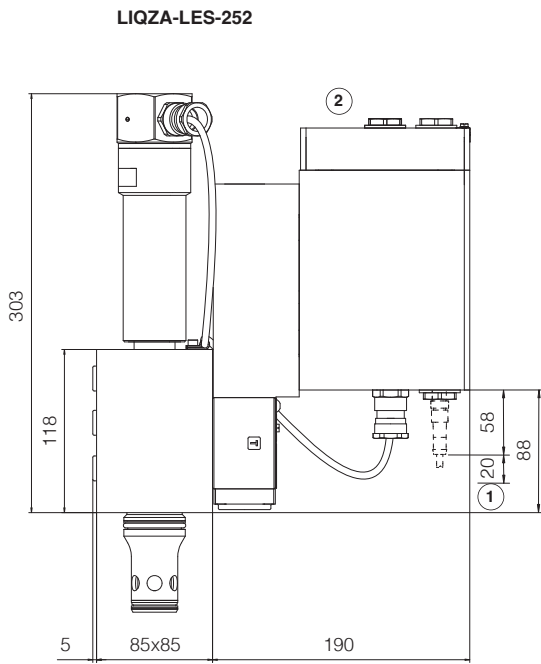

- ① = Space required for connection cable and for Bluetooth adapter or USB connector removal
- ② = The dimensions of all cable glands must be considered (see tech. table KX800)

Note: for mounting surface and cavity dimensions, see table P006

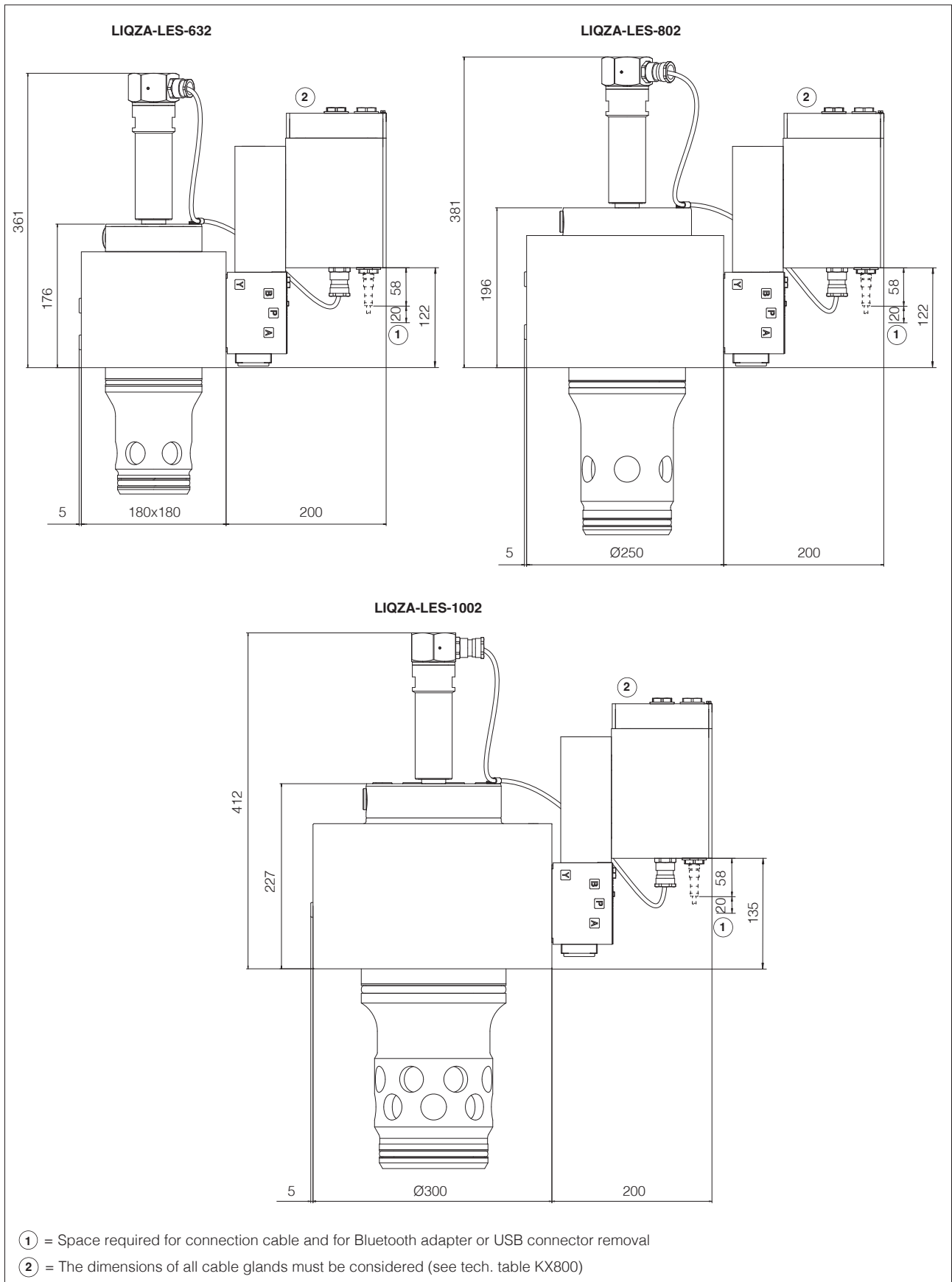

Note: for mounting surface and cavity dimensions, see table P006

21 RELATED DOCUMENTATION

X010 Basics for electrohydraulics in hazardous environments	KX800 Cable glands for ex-proof valves
X020 Summary of Atos ex-proof components certified to ATEX, IECEx, EAC, PESO, CCC	P006 Mounting surfaces and cavities for cartridge valves
FX900 Operating and maintenance information for ex-proof proportional valves	E-MAN-RA-LES TES/LES user manual
GS500 Programming tools	E-MAN-RA-LES-S TES/LES with p/Q control user manual
GS510 Fieldbus	