

Ex-proof proportional flow valves

pressure compensated, without transducer - **ATEX, IECEx, EAC, PESO, CCC** or **cULus**

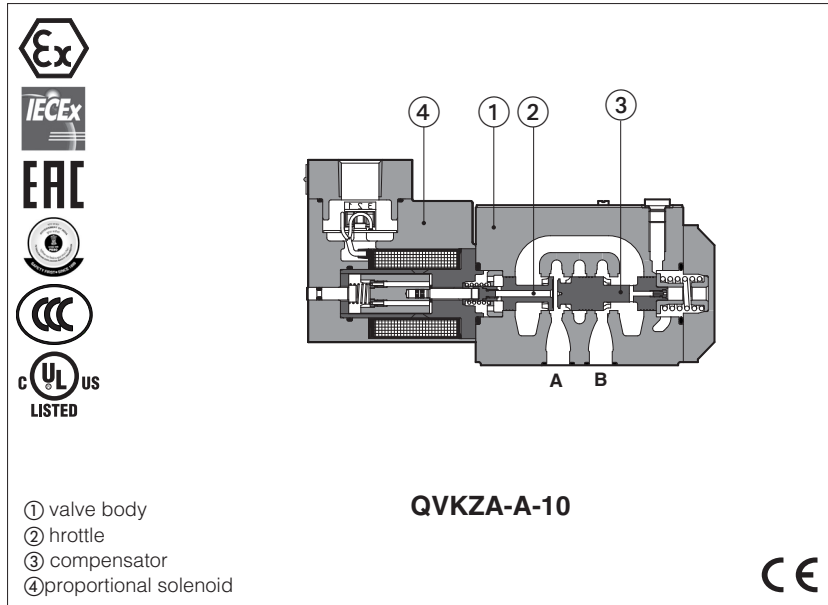

QVHZA-A, QVKZA-A

Ex-proof proportional flow valves, without position transducer for pressure compensated flow regulations.

They are equipped with ex-proof proportional solenoids certified for safe operations in hazardous environments with potentially explosive atmosphere.

Certifications:

- Multicertification **ATEX, IECEx, EAC, PESO, CCC** for gas group **II 2G** and dust category **II 2D**
- Multicertification **ATEX, IECEx**, for gas group **I M2** (mining)
- **cULus** North American certification for gas group **C&D**

The flameproof enclosure of solenoid prevents the propagation of accidental internal sparks or fire to the external environment.

The solenoid is also designed to limit the surface temperature within the classified limits.

QVHZA:

Size: **06** - ISO 4401
Max flow: **45 l/min**
Max pressure: **210 bar**

QVKZA:

Size: **10** - ISO 4401
Max flow: **90 l/min**
Max pressure: **210 bar**

1 MODEL CODE

QVKZA	/	*	-	A	-	10	/	90	/	M	/	*	/	*	/	*	/	*										
<p>Ex-proof pressure compensated proportional flow valves, direct</p> <p>QVHZA = size 06 QVKZA = size 10</p> <p>Certification type: Multicertification ATEX, IECEx, EAC, PESO, CCC: - = omit for Group II 2G / 2D (1) M = Group I M2 (mining) North American Certification: UL = cULus</p> <p>A = without transducer</p> <p>Valve size ISO 4401: 06 = size 06 10 = size 10</p> <p>Max regulated flow:</p> <table border="0"> <tr> <td>QVHZA</td> <td>QVKZA</td> </tr> <tr> <td>3 = 3,5 l/min</td> <td>65 = 65 l/min</td> </tr> <tr> <td>12 = 12 l/min</td> <td>90 = 90 l/min</td> </tr> <tr> <td>18 = 18 l/min</td> <td></td> </tr> <tr> <td>36 = 35 l/min</td> <td></td> </tr> <tr> <td>45 = 45 l/min</td> <td></td> </tr> </table> <p>Options (3): D = quick venting of port B O = horizontal cable entrance (2) WP =  manual override protected by metallic cap</p> <p>Solenoid threaded connection for cable gland fitting: GK = GK-1/2" - not for cULus (4) M = M20x1,5 - not for cULus NPT = 1/2" NPT</p> <p style="text-align: right;">Seals material, see section [7]: - = NBR PE = FKM BT = HNBR (2)</p> <p style="text-align: right;">Series number</p> <p>Voltage code: - = standard coil for 24 Vdc Atos drivers 24 = optional coil for 24 VDC low current drivers</p>																	QVHZA	QVKZA	3 = 3,5 l/min	65 = 65 l/min	12 = 12 l/min	90 = 90 l/min	18 = 18 l/min		36 = 35 l/min		45 = 45 l/min	
QVHZA	QVKZA																											
3 = 3,5 l/min	65 = 65 l/min																											
12 = 12 l/min	90 = 90 l/min																											
18 = 18 l/min																												
36 = 35 l/min																												
45 = 45 l/min																												

- (1)** The valves with Multicertification for Group II are also certified for Indian market according to **PESO** (Petroleum and Explosives Safety Organization). The PESO certificate can be downloaded from www.atos.com
- (2)** Not for multicertification **M** group I (mining) **(3)** Possible combined options: /DO, /DWP, /DOWP, /OWP
- (4)** Approved only for the Italian market

2 HYDRAULIC SYMBOLS

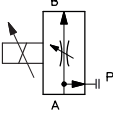
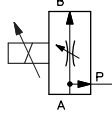
 <p>2 way connection</p>	 <p>3 way connection</p>	<p>The valves can be used in 2 or 3 way connection, depending to the application requirements.</p> <p>In 2 way the P port must not be connected (blocked) In 3 way the P port has to be connected to tank or to other user lines The port T must be always not connected (blocked) For application examples of 2 and 3 way connections, see section</p>
--	--	---

3 ELECTRONIC DRIVERS

Electronic drivers are factory set with max current limitation for ex-proof valves.

Please include in the driver order also the complete code of the connected ex-proof proportional valve.

Drivers model	E-BM-AS-* /A	E-BM-AES-* /A
Type	digital	digital
Format	DIN-rail panel	
Data sheet	G030	GS050

4 GENERAL CHARACTERISTICS

Assembly position	Any position
Subplate surface finishing to ISO 4401	Acceptable roughness index, Ra ≤0,8 recommended Ra 0,4 - flatness ratio 0,01/100
MTTFd valves according to EN ISO 13849	150 years, see technical table P007
Ambient temperature range	Standard = -20°C ÷ +70°C /PE option = -20°C ÷ +70°C /BT option = -40°C ÷ +70°C
Storage temperature range	Standard = -20°C ÷ +80°C /PE option = -20°C ÷ +80°C /BT option = -40°C ÷ +70°C
Surface protection	Zinc coating with black passivation - salt spray test (EN ISO 9227) > 200h
Compliance	Explosion proof protection, see section 8 -Flame proof enclosure "Ex d" -Dust ignition protection by enclosure "Ex t" RoHs Directive 2011/65/EU as last update by 2015/863/EU REACH Regulation (EC) n°1907/2006

5 HYDRAULIC CHARACTERISTICS - based on mineral oil ISO VG 46 at 50°C

Valve model	QVHZA					QVKZA		
	[l/min]							
Max regulated flow	3,5	12	18	35	45	65	90	
Min regulated flow	[cm³/min]	15	20	30	50	60	85	
Regulating Δp	[bar]	4 - 6		10 - 12		15	6 - 8	
Max flow on port A	[l/min]	40			50	55	70	
Max pressure	[bar]	210						
Response time (1)	[ms]	≤ 35					≤ 50	
Hysteresis		≤ 5 [% of the regulated max flow]						
Linearity		≤ 3 [% of the regulated max flow]						
Repeatability		≤ 1 [% of the regulated max flow]						

Note: above performance data refer to valves coupled with Atos electronic drivers, see section 3

(1) 0 ÷ 100% step signal

6 ELECTRICAL CHARACTERISTICS

Max. power	35W	
Insulation class	H (180°) Due to the occurring surface temperatures of the solenoid coils, the European standards ISO 13732-1 and EN982 must be taken into account	
Protection degree with relevant cable gland	Multicertification: IP66/67 to DIN EN60529 UL: raintight enclosure, UL approved	
Duty factor	Continuous rating (ED=100%)	
Voltage code	standard	option /24
Coil resistance R at 20°C	3,2 Ω	17,6 Ω
Max. solenoid current	2,5 A	1,1 A

7 SEALS AND HYDRAULIC FLUIDS - for other fluids not included in below table, consult our technical office

Seals, recommended fluid temperature	NBR seals (standard) = -20°C ÷ +60°C, with HFC hydraulic fluids = -20°C ÷ +50°C FKM seals (/PE option) = -20°C ÷ +80°C HNBR seals (/BT option) = -40°C ÷ +60°C, with HFC hydraulic fluids = -40°C ÷ +50°C		
Recommended viscosity	20 ÷ 100 mm²/s - max allowed range 15 ÷ 380 mm²/s		
Max fluid contamination level	normal operation	ISO4406 class 18/16/13 NAS1638 class 7	see also filter section at www.atos.com or KTF catalog
	longer life	ISO4406 class 16/14/11 NAS1638 class 5	
Hydraulic fluid	Suitable seals type	Classification	Ref. Standard
Mineral oils	NBR, FKM, HNBR	HL, HLP, HLPD, HVL, HVLDP	DIN 51524
Flame resistant without water	FKM	HFDR, HFDR	ISO 12922
Flame resistant with water (1)	NBR, HNBR	HFC	

 The ignition temperature of the hydraulic fluid must be 50°C higher than the max solenoid surface temperature

(1) Performance limitations in case of flame resistant fluids with water:

- max operating pressure = 180 bar
- max fluid temperature = 50°C

8 CERTIFICATION DATA

Valve type	QVHZA, QVKZA		QVHZA/M, QVHZA/M	QVHZA/UL, QVHZA/UL	
Certifications	Multicertification Group II ATEX, IECEX, EAC, PESO, CCC		Multicertification Group I ATEX, IECEX, CCC	North American cULus	
Solenoid certified code	OZA-A		OZAM-A	OZA-A/EC	
Type examination certificate (1)	ATEX: CESI 02 ATEX 014 IECEX: IECEX CES 10.0010x EAC: RU C - IT.AX38.B.00425/21 PESO: P588812/4 CCC: 2024322307005903		ATEX: CESI 03 ATEX 057x IECEX: IECEX CES 12.0007x	20170324 - E366100	
Method of protection	<ul style="list-style-type: none"> • ATEX, EAC Ex II 2G Ex db IIC T4/T3 Gb Ex II 2D Ex tb IIIC T135°C/T200°C Db • IECEX, CCC Ex db IIC T4/T3 Gb Ex tb IIIC T135°C/T200°C Db • PESO Ex db IIC T4/T3 Gb • EAC 1Ex d IIC T4/T3 Gb X Ex tb IIIC T135°C/T200°C Db X 		<ul style="list-style-type: none"> • ATEX Ex I M2 Ex db I Mb • IECEX Ex db I Mb 	<ul style="list-style-type: none"> • UL 1203 Class I, Div. I, Groups C & D Class I, Zone I, Groups IIA & IIB 	
Temperature class	T4	T3	-	T4	T3
Surface temperature	≤ 135°C	≤ 200°C	≤ 150°C	≤ 135°C	≤ 200°C
Ambient temperature (2)	-40 ÷ +40°C	-40 ÷ +70°C	-20 ÷ +60°C	-40 ÷ +55°C	-40 ÷ +70°C
Applicable standards	EN 60079-0 EN 60079-1 EN 60079-31		IEC 60079-0 IEC 60079-1 IEC 60079-31	UL 1203 and UL429, CSA 22.2 n°30-1986 CSA 22.2 n°139-13	
Cable entrance: threaded connection vertical (standard) or horizontal (option /O)	GK = GK-1/2"	M = M20x1,5	NPT = 1/2" NPT	1/2" NPT	

(1) The type examination certificates can be downloaded from www.atos.com

(2) The solenoids **Group II** and **cULus** are certified for minimum ambient temperature -40°C

In case the complete valve must withstand with minimum ambient temperature of -40°C, select **/BT** in the model code

⚠ WARNING: service work performed on the valve by the end users or not qualified personnel invalidates the certification

9 EX PROOF SOLENOIDS WIRING

Multicertification

Standard version Option /O

① cover with threaded connection for vertical cable gland fitting
② cover with threaded connection for horizontal cable gland fitting
③ terminal board for cables wiring
④ standard manual override
⑤ screw terminal for additional equipotential grounding

1 = Coil PCB 3 poles terminal board suitable for wires cross sections up to 2,5 mm² (max AWG14)
2 = GND
3 = Coil

cULus certification

Standard version Option /O

① cover with threaded connection for vertical cable gland fitting
② cover with threaded connection for horizontal cable gland fitting
③ terminal board for cables wiring
④ standard manual override

1 = Coil + PCB 3 poles terminal board suggested cable section up to 1,5 mm² (max AWG16), see section 10 note 1
2 = GND
3 = Coil -
 alternative GND screw terminal connected to solenoid housing

⚠ Pay attention to respect the polarity

10 CABLE SPECIFICATION AND TEMPERATURE - Power supply and grounding cables have to comply with following characteristics:

Multicertification Group I and Group II	
Power supply: section of coil connection wires = 2,5 mm ²	Grounding: section of internal ground wire = 2,5 mm ² section of external ground wire = 4 mm ²
cULus certification:	
<ul style="list-style-type: none"> Suitable for use in Class I Division 1, Gas Groups C Armored Marine Shipboard Cable which meets UL 1309 Tinned Stranded Copper Conductors Bronze braided armor Overall impervious sheath over the armor 	
Any Listed (UBVZ/UBVZ7) Marine Shipboard Cable rated 300 V min, 15A min. 3C 2,5 mm ² (14 AWG) having a suitable service temperature range of at least -25°C to +110°C ("BT" Models require a temperature range from -40°C to +110°C)	
Note 1: For Class I wiring the 3C 1,5 mm ² AWG 16 cable size is admitted only if a fuse lower than 10 A is connected to the load side of the solenoid wiring.	

10.1 Cable temperature

The cable must be suitable for the working temperature as specified in the "safety instructions" delivered with the first supply of the products.

Multicertification

Max ambient temperature [°C]	Temperature class		Max surface temperature [°C]		Min. cable temperature [°C]	
	Group I	Group II	Group I	Group II	Group I	Group II
40°C	-	T4	150°C	135°C	90°C	90°C
45°C	-	T4	-	135°C	-	95°C
55°C	-	T3	-	200°C	-	110°C
60°C	-	-	150°C	-	110°C	-
70°C	N.A.	T3	N.A.	200°C	N.A.	120°C

cULus certification

Max ambient temperature [°C]	Temperature class	Max surface temperature [°C]	Min. cable temperature
55°C	T4	135°C	100°C
70°C	T3	200°C	100°C

11 CABLE GLANDS - only **Multicertification**

Cable glands with threaded connections GK-1/2", 1/2"NPT or M20x1,5 for standard or armoured cables have to be ordered separately, see tech. table **KX600**

Note: a Loctite sealant type 545, should be used on the cable gland entry threads

12 OPTIONS

D = This option provides a quick venting of the use port B when the valve is closed or de-energized. The valve must be connected in 3 way, with P port connected to tank. When the proportional throttle is fully closed, the valve's port B is internally connected to port P (tank), permitting a quickly decompression of the pressure in the use line.

In the diagram aside are represented the venting times of **QVHZA** and **QVKZA** option /D respect to standard versions:

- 1** = standard versions
- 2** = option /D

O = Horizontal cable entrance, to be selected in case of limited vertical space.

WP = Manual override protected by metallic cap.

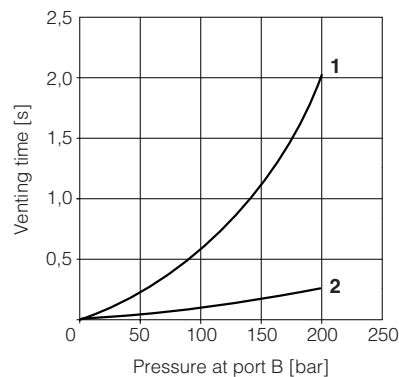

13 DIAGRAMS - based on mineral oil ISO VG 46 at 50°C

13.1 Regulation diagrams

- 1 = QVHZA-*-06/3
- 2 = QVHZA-*-06/12
- 3 = QVHZA-*-06/18
- 4 = QVHZA-*-06/36
- 5 = QVHZA-*-06/45
- 6 = QVKZA-*-10/65
- 7 = QVKZA-*-10/90

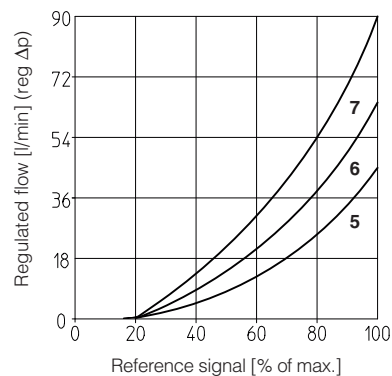
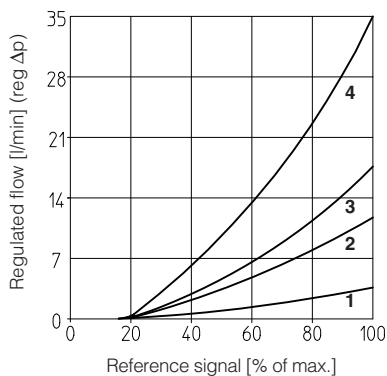

13.2 Regulated flow/outlet pressure diagrams
with inlet pressure = 210 bar

- 1 = QVHZA
- 2 = QVKZA

Dotted line for 3-way versions

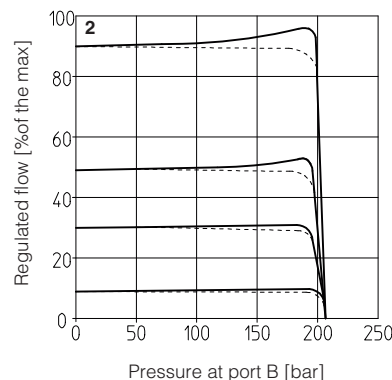
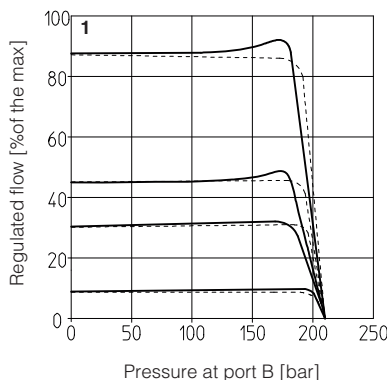

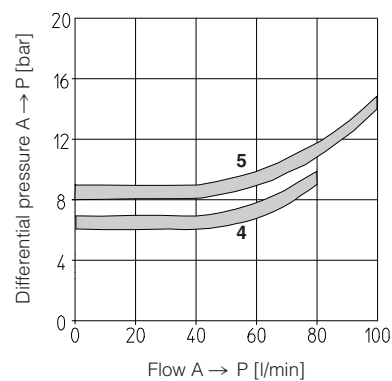
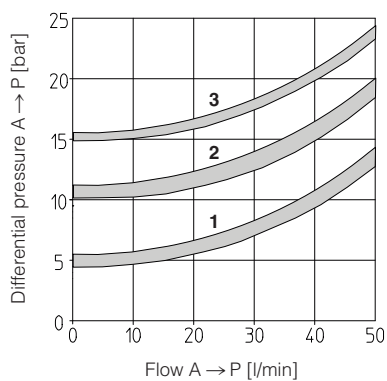

13.3 Flow A → P/Δp diagrams
3-way configuration

- 1 = QVHZA-*-06/3
- QVHZA-*-06/12
- 2 = QVHZA-*-06/18
- QVHZA-*-06/36
- 3 = QVHZA-*-06/45
- 4 = QVKZA-*-10/65
- 5 = QVKZA-*-10/90

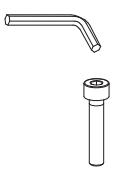

14 FASTENING BOLTS AND SEALS

	QVHZA	QVKZA
	<p>Fastening bolts: 4 socket head screws M5x50 class 12.9 Tightening torque = 8 Nm</p>	<p>Fastening bolts: 4 socket head screws M6x40 class 12.9 Tightening torque = 15 Nm</p>
	<p>Seals: 4 OR 108; Diameter of ports A, B, P, T: Ø 7,5 mm (max)</p>	<p>Seals: 5 OR 2050; Diameter of ports A, B, P, T: Ø 11,2 mm (max)</p>

15 INSTALLATION DIMENSIONS [mm]

QVHZA-A

ISO 4401: 2005 (see tab. P005)

Mounting surface: 4401-03-02-0-05

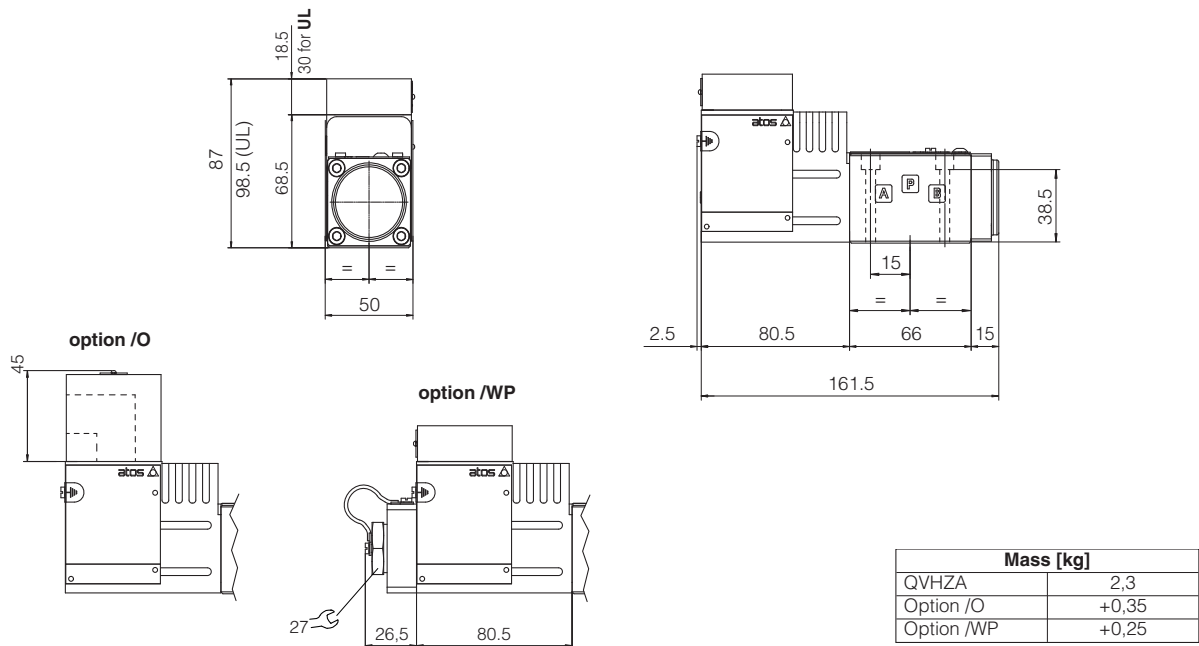

QVKZA-A

ISO 4401: 2005

Mounting surface: 4401-05-04-0-05 (see tab. P005)

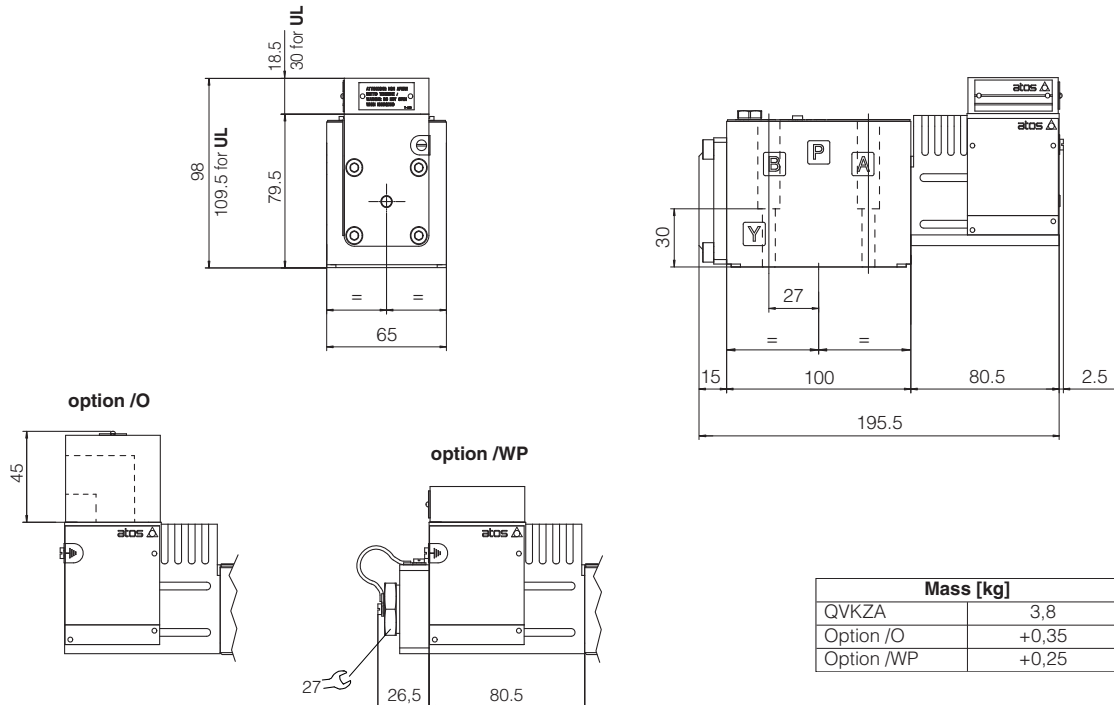

16 RELATED DOCUMENTATION

- X010** Basics for electrohydraulics in hazardous environments
- X020** Summary of Atos ex-proof components certified to ATEX, IECEx, EAC, CCC, PESO
- X030** Summary of Atos ex-proof components certified to cULus
- FX900** Operating and maintenance information for ex-proof proportional valves
- KX800** Cable glands for ex-proof valves
- P005** Mounting surfaces for electrohydraulic valves