

2 POSITION CONTROL

2.1 External reference signal

Axis card controls in closed loop the actuator position according to a position reference signal from the machine central unit.

Position profile can be managed in two ways (software selectable):

- Without trajectory generation **(a)**: the axis card receives from the machine central unit the position reference signal and follows it at any given instant
- With trajectory generation **(b)**: the axis card receives from the machine central unit just the final target position and internally generates a position profile limiting acceleration, velocity and deceleration

The position reference signal can be software selected between Analog reference **(c)** and Fieldbus reference **(d)**.

Refer to the axis card user manual for further details on position control features.

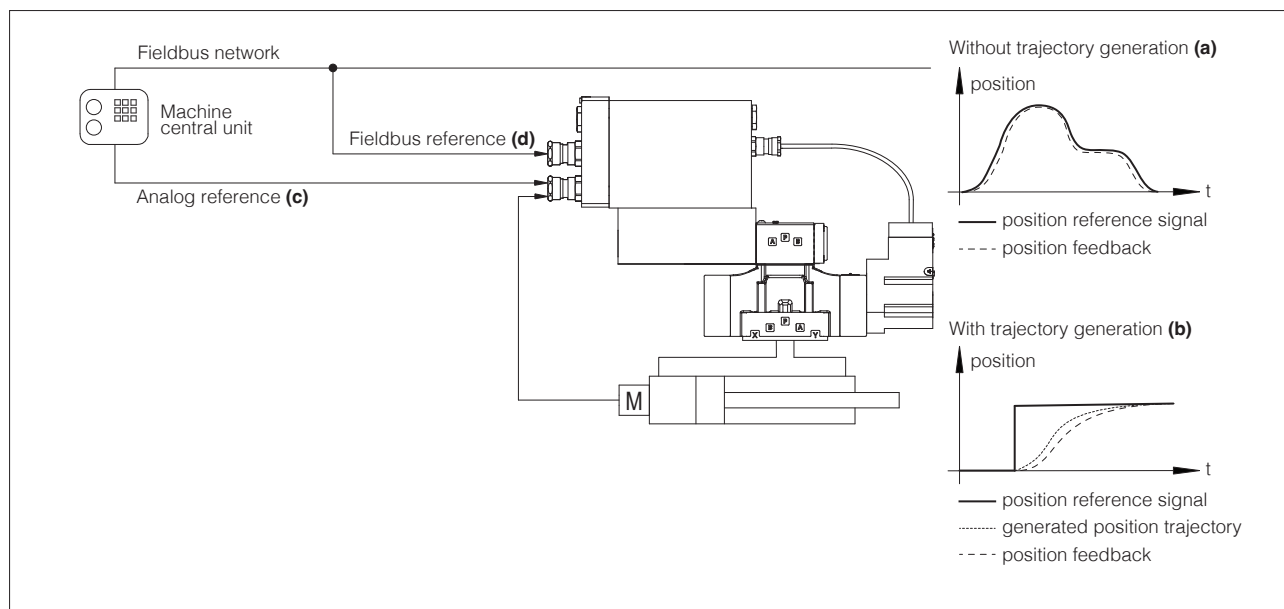

2.2 Automatic cycle

Axis card controls in closed loop the actuator position according to an internally generated automatic cycle: only start, stop and switch-over commands are required from the machine electronic central unit by means On-off commands **(e)** or Fieldbus commands **(f)**.

Atos PC software allows to realize an automatic cycle according to the application requirements. Refer to the axis card user manual for further details on automatic cycle features.

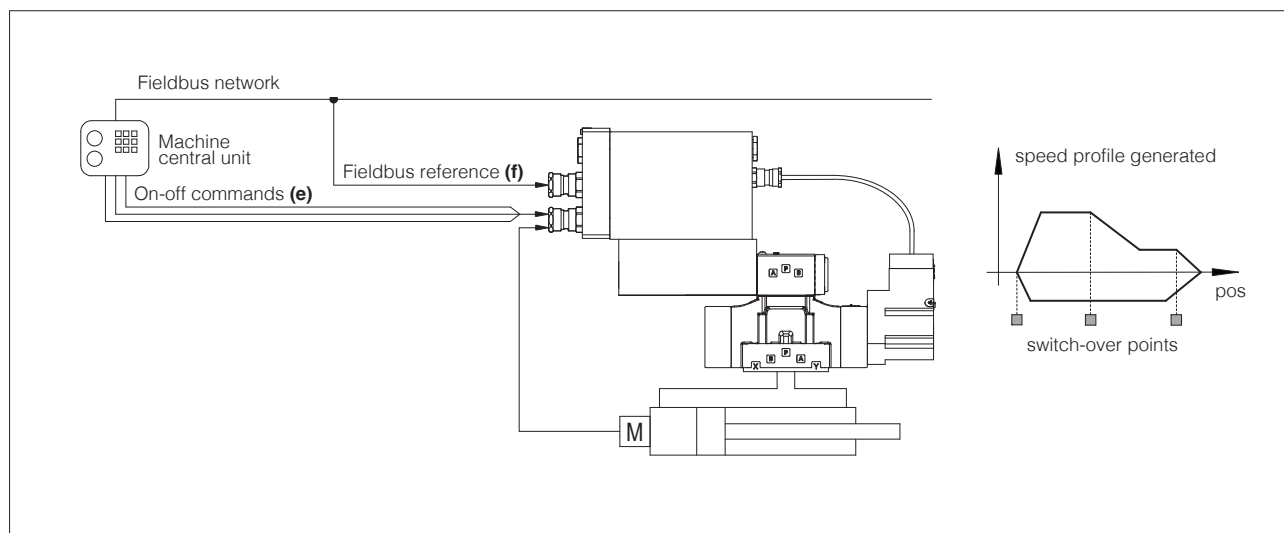

3 ALTERNATED POSITION / FORCE CONTROL

SF and **SL** controls add the alternated force closed loop control to the actuator standard position control. Pressure or force remote transducers have to be installed on the actuator and interfaced to the valve, see below functional schemes.

The position/force controls are operated according to two separate reference signals and a dedicated algorithm automatically selects which control is active time by time.

The dynamics of the switching between the two controls can be regulated thanks to specific software setting, in order to avoid instability and vibrations.

Position control is active (see phase ① and ③ at side) when the actuator force is lower than the relevant reference signal - the valve controls the actuator position by closed-loop regulation.

Force control is active (see phase ② and ④ at side) when the actuator actual force, measured by remote transducers, grows up to the relevant reference signal - the axis card reduces the valve's regulation in order to limit the actuator force; if the force tends to decrease under its reference signal, the position control returns active.

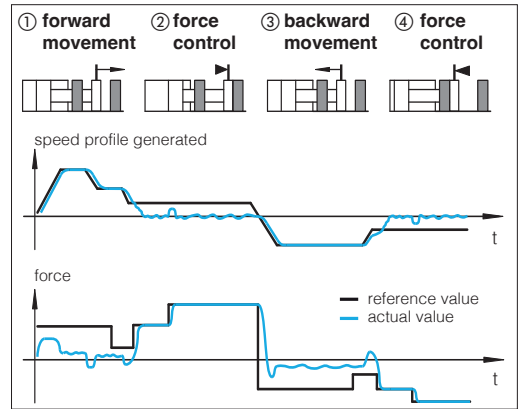

Alternated control configurations

| SF | SL |
|--|--|
| | |
| <p>two remote pressure transducers have to be installed on the actuator's ports; the actuator force is calculated by the pressure feedbacks ($P_a - P_b$)</p> | <p>one load cell transducer has to be installed between the actuator and the controlled load</p> |

| | | | |
|---------------------------------|---------------------------------------|------------------------------|--------------------|
| T valve spool transducer | M actuator position transducer | P pressure transducer | L load cell |
|---------------------------------|---------------------------------------|------------------------------|--------------------|

SF – position/force control

Adds force control to standard position control and permits to limit the max force in two directions controlling in closed loop the delta pressure acting on both sides of the hydraulic actuator. Two pressure transducers have to be installed on A and B hydraulic lines.

SL – position/force control

Adds force control to standard position control and permits to limit the max force in one or two directions controlling in closed loop the force performed by the hydraulic actuator. A load cell has to be installed on the hydraulic actuator.

General Notes:

- auxiliary check valves are recommended in case of specific hydraulic configuration requirements in absence of power supply or fault
- Atos technical office is available for additional evaluations related to specific applications

4 GENERAL NOTES

Atos digital proportionals valves are CE marked according to the applicable directives (e.g. Immunity and Emission EMC Directive). Installation, wirings and start-up procedures must be performed according to the general prescriptions shown in tech table **FX900** and in the user manuals included in the Z-SW-SETUP programming software.

5 VALVE SETTINGS AND PROGRAMMING TOOLS - see tech. table **GS500**

Free downloadable software for PC allows to set all valve functional parameters and to access complete diagnostic information of digital axis controls via Bluetooth/USB service port. Atos Z-SW-SETUP PC software supports all Atos digital axis controls and it is available at www.atos.com in MyAtos area.

WARNING: axis card USB port is not isolated! For E-C-SB-USB/M12 cable, the use of E-A-SB-USB/OPT isolator adapter is highly recommended for PC protection

WARNING: for the list of countries where the Bluetooth adapter has been approved, see tech. table **GS500**

Bluetooth or USB connection

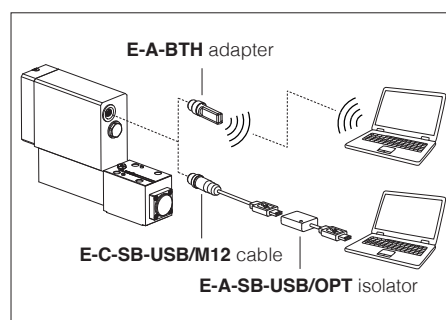

6 SMART START-UP

The automatic procedure supports the user during the commissioning phases of the axis control with guided procedures:

• General setting

It assists the user in system data setup, as like cylinder stroke, diameters, load mass, configure analog/digital signals and communication interface, position transducer setup.

• System check

It automatically executes position open loop movements to set axis control parameters, position transducer calibration and verify cylinder stroke.

• Position autotuning

It automatically determines the optimal PID parametrization of the position control adapting the dynamic response to guarantee control precision and axis stability. Once the procedure is started, the control performs few automatic position open loop movements of the actuator, during which control parameters are calculated and stored.

7 SMART TUNING

Once the Smart Start-up procedure has been completed, the Smart tuning feature allows to further refine the position control response by choosing from 3 different levels of performance in positioning:

- **dynamic** best dynamics and accuracy (default factory setting)
- **balanced** average dynamics and accuracy
- **smooth** attenuated dynamics and accuracy to improve control stability in critical applications or in environments with electrical disturbances

Settings can be changed any time via Z-SW-SETUP software or fieldbus.

If required, control performance can be further customized by modifying PID parameter via Z-SW-SETUP software.

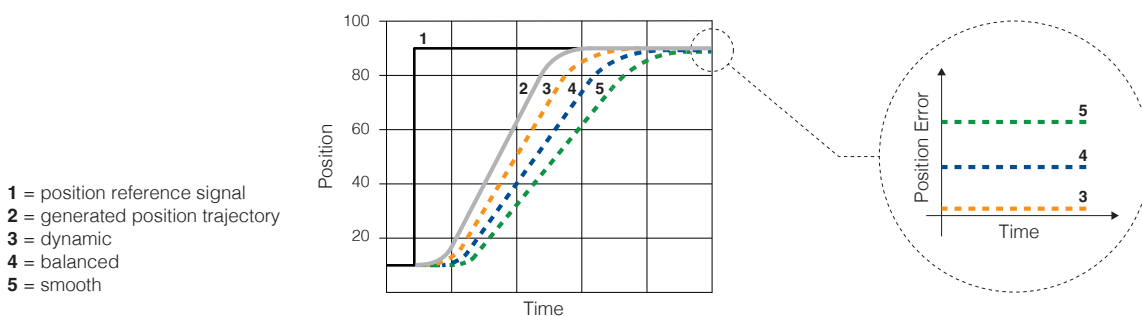

8 MULTIPLE SETS

Multiple PID sets allows to easily switch axis behaviour according to machine cycle, selecting between independent groups of parameters for:

- **position control PID**
- **force control PID and p/Q logics switching criteria**

Settings can be changed any time via Z-SW-SETUP software, fieldbus or digital input signals.

9 FIELDBUS - see tech. table **GS510**

Fieldbus allows valve direct communication with machine control unit for digital reference, valve diagnostics and settings. These executions allow to operate the valves through fieldbus or analog signals available on the terminal board.

10 GENERAL CHARACTERISTICS

| | |
|--|---|
| Assembly position | Any position |
| Subplate surface finishing to ISO 4401 | Acceptable roughness index: Ra ≤0,8, recommended Ra 0,4 – Flatness ratio 0,01/100 |
| MTTFd values according to EN ISO 13849 | 75 years, for further details see technical table P007 |
| Ambient temperature range | Standard = -20°C ÷ +60°C /PE option = -20°C ÷ +60°C /BT option = -40°C ÷ +60°C |
| Storage temperature range | Standard = -20°C ÷ +70°C /PE option = -20°C ÷ +70°C /BT option = -40°C ÷ +70°C |
| Surface protection | Zinc coating with black passivation |
| Corrosion resistance | Salt spray test (EN ISO 9227) > 200 h |
| Vibration resistance | See technical table GX004 |
| Compliance | Explosion proof protection, see section 14 -Flame proof enclosure “Ex d” -Dust ignition protection by enclosure “Ex t” CE according to EMC directive 2014/30/EU (Immunity: EN 61000-6-2; Emission: EN 61000-6-3) RoHS Directive 2011/65/EU as last update by 2015/863/EU REACH Regulation (EC) n°1907/2006 |

11 HYDRAULIC CHARACTERISTICS - based on mineral oil ISO VG 46 at 50 °C

| Valve model | DPZA*-1 | DPZA*-2 | | DPZA*-4 | DPZA*-4M | | |
|---------------------------|--|-----------|----------------|-----------|----------------|---------|---------|
| Pressure limits [bar] | ports P, A, B, X = 350; T = 250 (10 for option /D); Y = 10; | | | | | | |
| Spool type and size | L5, DL5 | L3 | L5, DL5 | T5 | L5, DL5 | | |
| Nominal flow [l/min] | | | | | | | |
| Δp P-T | Δp = 10 bar | 100 | 130 | 200 | 150 | 340 | 390 |
| | Δp = 30 bar | 160 | 220 | 350 | 260 | 590 | 670 |
| | Max permissible flow | 180 | 320 | 440 | 360 | 680 | 800 |
| Δp max P-T [bar] | 50 | 60 | 60 | 60 | 60 | 60 | 60 |
| Piloting pressure [bar] | min. = 25; max = 350 (option /G advisable for pilot pressure > 200 bar) | | | | | | |
| Piloting volume [cm³] | 1,4 | | 3,7 | | 9,0 | 11,3 | |
| Piloting flow (1) [l/min] | 1,7 | | 3,7 | | 6,8 | 8 | |
| Leakage (2) | Pilot [cm³/min] | 100/300 | | 150/450 | | 200/600 | 200/600 |
| | Main stage [l/min] | 0,4/1,2 | | 0,6/2,5 | | 1,0/4,0 | 1,0/4,0 |
| Response time (1) [ms] | ≤ 30 | | ≤ 30 | | ≤ 35 | ≤ 40 | |
| Hysteresis | ≤ 0,1 [% of max regulation] | | | | | | |
| Repeatability | ± 0,1 [% of max regulation] | | | | | | |

(1) 0 ÷ 100 % step signal and pilot pressure 100 bar

(2) At P = 100/350 bar

12 ELECTRICAL CHARACTERISTICS

| | | | | |
|--|---|------------------------------------|---|---|
| Power supplies | Nominal : +24 VDC Rectified and filtered : $V_{RMS} = 20 \div 32 V_{MAX}$ (ripple max 10 % VPP) | | | |
| Max power consumption | 35 W | | | |
| Analog input signals | Voltage: range ± 10 VDC (24 VMAX tolerant) Current: range ± 20 mA | | Input impedance: $R_i > 50$ k Ω Input impedance: $R_i = 500$ Ω | |
| Monitor outputs | Output range: voltage ± 10 VDC @ max 5 mA current ± 20 mA @ max 500 Ω load resistance | | | |
| Enable input | Range: 0 \div 5 Vdc (OFF state), 9 \div 24 Vdc (ON state), 5 \div 9 Vdc (not accepted); Input impedance: $R_i > 10$ k Ω | | | |
| Fault output | Output range: 0 \div 24 Vdc (ON state > [power supply - 2 V] ; OFF state < 1 V) @ max 50 mA; external negative voltage not allowed (e.g. due to inductive loads) | | | |
| Position transducers power supply | +24 Vdc @ max 100 mA and +5 Vdc @ max 100 mA are software selectable; ± 10 Vdc @ max 14 mA minimum load resistance 700 Ω | | | |
| Pressure/Force transducer power supply (only for SF, SL) | +24Vdc @ max 100 mA (E-ATRA-7 see tech table GX800) | | | |
| Alarms | Solenoid not connected/short circuit, cable break with current reference signal, over/under temperature, valve spool transducer malfunctions, alarms history storage function | | | |
| Insulation class | H (180°) Due to the occurring surface temperatures of the solenoid coils, the European standards ISO 13732-1 and EN982 must be taken into account | | | |
| Protection degree to DIN EN60529 | IP66 / IP67 with relevant cable gland | | | |
| Duty factor | Continuous rating (ED=100%) | | | |
| Tropicalization | Tropical coating on electronics PCB | | | |
| Additional characteristics | Short circuit protection of solenoid's current supply; 3 leds for diagnostic; protection against reverse polarity of power supply | | | |
| Communication interface | USB Atos ASCII coding | CANopen EN50325-4 + DS408 | PROFIBUS DP EN50170-2/IEC61158 | EtherCAT, POWERLINK, EtherNet/IP, PROFINET IO RT / IRT EC 61158 |
| Communication physical layer | not insulated USB 2.0 + USB OTG | optical insulated CAN ISO 11898 | optical insulated RS485 | Fast Ethernet, insulated 100 Base TX |

Note: a maximum time of 800 ms (depending on communication type) has to be considered between the axis card energizing with the 24 VDC power supply and when the valve is ready to operate. During this time the current to the valve coils is switched to zero.

13 SEALS AND HYDRAULIC FLUIDS - for other fluids not included in below table, consult our technical office

| | | | |
|---------------------------------------|---|--|-----------------------------|
| Seals, recommended fluid temperature | NBR seals (standard) = -20°C \div +60°C, with HFC hydraulic fluids = -20°C \div +50°C FKM seals (/PE option) = -20°C \div +80°C NBR low temp. seals (/BT option) = -40°C \div +60°C, with HFC hydraulic fluids = -20°C \div +50°C | | |
| Recommended viscosity | 20 \div 100 mm ² /s - max allowed range 15 \div 380 mm ² /s | | |
| Max fluid contamination level | normal operation | ISO4406 class 18/16/13 NAS1638 class 7 | see also filter section at |
| | longer life | ISO4406 class 16/14/11 NAS1638 class 5 | www.atos.com or KTF catalog |
| Hydraulic fluid | Suitable seals type | Classification | Ref. Standard |
| Mineral oils | NBR, FKM, NBR low temp. | HL, HLP, HLPD, HVLP, HVLPD | DIN 51524 |
| Flame resistant without water | FKM | HFDU, HFDR | ISO 12922 |
| Flame resistant with water (1) | NBR, NBR low temp. | HFC | |

 The ignition temperature of the hydraulic fluid must be 50°C higher than the max solenoid surface temperature

(1) Performance limitations in case of flame resistant fluids with water:

- max operating pressure = 210 bar
- max fluid temperature = 50°C

14 CERTIFICATION DATA

| | | | |
|--|---|--|----------------------------|
| Valve type | DPZA | | |
| Certifications | Multicertification Group II ATEX IECEx EAC CCC | | |
| Solenoid, transducer | Solenoid | Transducer | |
| Solenoid and transducer certified code | OZA-LEZ | ETHA-4* | |
| Type examination certificate (1) | <ul style="list-style-type: none"> • ATEX: TUV IT 18 ATEX 068 X • IECEx: IECEx TPS 19.0004X • EAC: RU C - IT.AK38.B.00425/21 • CCC: 2024322307006321 | <ul style="list-style-type: none"> • ATEX: CESI 02 ATEX 015X / 06 • IECEx: IECEx CES 12.006X • EAC: RU C - IT.AK38.B.00425/21 • CCC: 2024322315005904 | |
| Method of protection | <ul style="list-style-type: none"> • ATEX: Ex II 2G Ex db IIC T6/T5/T4 Gb; Ex II 2D Ex tb IIIC T85°C/T100°C/T135°C Db • IECEx, CCC: Ex db IIC T6/T5/T4 Gb; Ex tb IIIC T85°C/T100°C/T135°C Db • EAC: 1Ex d IIC T6/T5/T4 Gb X; Ex tb IIIC T85°C/T100°C/T135°C Db X | <ul style="list-style-type: none"> • ATEX: Ex II 2G Ex db IIC T6/T5/T4 Gb; Ex II 2D Ex tb IIIC T85°C/T100°C/T135°C Db • IECEx, CCC: Ex db IIC T6/T5/T4 Gb; Ex tb IIIC T85°C/T100°C/T135°C Db • EAC: 1Ex d IIC T4/T3 Gb X; Ex tb IIIC T135°C/T200°C Db X | |
| Temperature class | T6 | T5 | T4 |
| Surface temperature | ≤ 85 °C | ≤ 100 °C | ≤ 135 °C |
| Ambient temperature (2) | -40 ÷ +40 °C | -40 ÷ +55 °C | -40 ÷ +70 °C |
| Applicable Standards | EN 60079-0 IEC 60079-0 | EN 60079-1 IEC 60079-31 | EN 60079-31 IEC 60079-1 |
| Cable entrance: threaded connection | M = M20x1,5 | | |

(1) The type examination certificates can be downloaded from www.atos.com

(2) The driver and solenoids are certified for minimum ambient temperature -40°C.
In case the complete valve must withstand with minimum ambient temperature -40°C, select /BT in the model code.

⚠ WARNING: service work performed on the valve by the end users or not qualified personnel invalidates the certification.

15 CABLE SPECIFICATION AND TEMPERATURE - Power supply and grounding cables have to comply with following characteristics:

Power supply and signals: section of wire = 1,0 mm² **Grounding:** section of external ground wire = 4 mm²

15.1 Cable temperature

The cable must be suitable for the working temperature as specified in the "safety instructions" delivered with the first supply of the products.

| Max ambient temperature [°C] | Temperature class | Max surface temperature [°C] | Min. cable temperature [°C] |
|------------------------------|-------------------|------------------------------|-----------------------------|
| 40 °C | T6 | 85 °C | 80 °C |
| 55 °C | T5 | 100 °C | 90 °C |
| 70 °C | T4 | 135 °C | 110 °C |

16 CABLE GLANDS

Cable glands with threaded connections M20x1,5 for standard or armoured cables have to be ordered separately, see tech table **KX800**

Note: a Loctite sealant type 545, should be used on the cable gland entry threads

17 HYDRAULIC OPTIONS

B = Solenoid, on-board digital driver + axis card and LVDT position transducer at side of port B of the main stage.

D and E = Pilot and drain configuration can be modified as shown in section [26].
The valve's standard configuration provides internal pilot and external drain.

For different pilot / drain configuration select:

- Option /D Internal drain.
- Option /E External pilot (through port X).

G = Pressure reducing valve installed between pilot valve and main body with fixed setting:

- DPZA-2 = 28 bar
- DPZA-2, -4 and -4M = 40 bar

It is advisable for valves with internal pilot in case of system pressure higher than 150 bar.

Pressure reducing valve is standard for DPZA-1, for other sizes add /G option.

FUNCTIONAL SCHEME - example of configuration 70

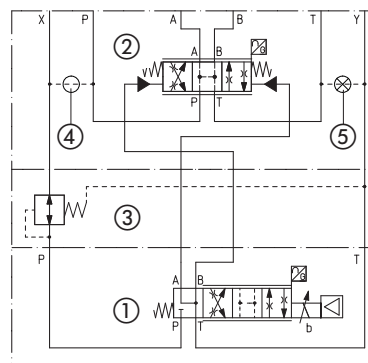

- ① Pilot valve
- ② Main stage
- ③ Pressure reducing valve
- ④ Plug to be added for external pilot trough port X
- ⑤ Plug to be removed for internal drain through port T

18 ELECTRONIC OPTIONS

I = This option provides 4 ÷ 20 mA current reference signal, instead of the standard ±10 VDC.

Input signal can be reconfigured via software selecting between voltage and current, within a maximum range of ±10 Vdc or ±20 mA.
It is normally used in case of long distance between the machine control unit and the valve or where the reference signal can be affected by electrical noise; the valve functioning is disabled in case of reference signal cable breakage.

C = This option is available to connect analog position transducer and pressure/force transducers with 4 ÷ 20 mA current output signal, instead of the standard ±10 VDC.
Input signal can be reconfigured via software selecting between voltage and current, within a maximum range of ±10 Vdc or ±20 mA.

19 DIAGRAMS (based on mineral oil ISO VG 46 at 50 °C)

19.1 Regulation diagrams (values measure at Δp 10 bar P-T)

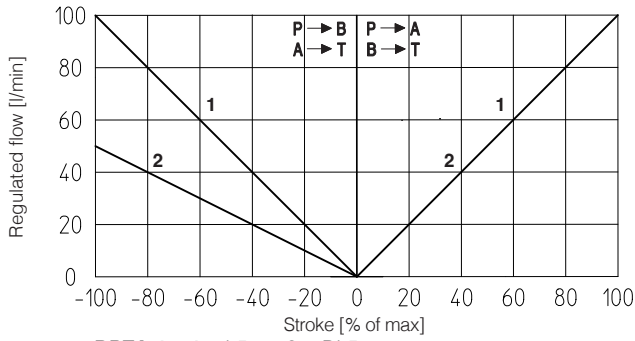

DPZA-1: 1 = L5 2 = DL5

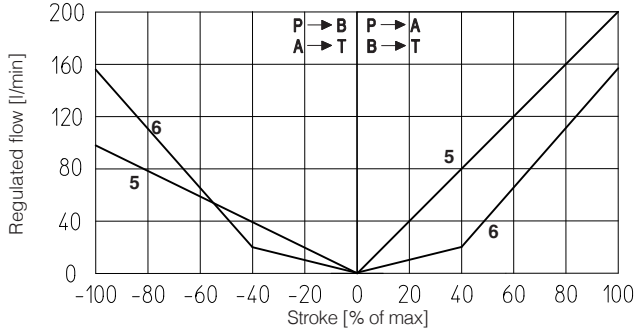

DPZA-2: 5 = DL5 6 = T5

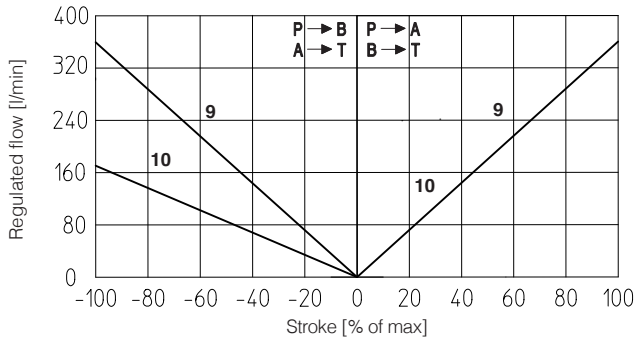

DPZA-4M: 9 = L5 10 = DL5

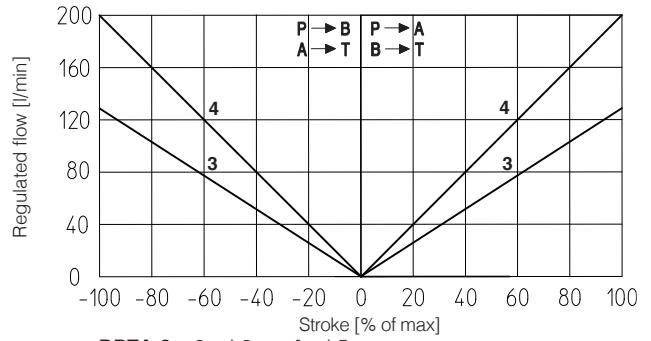

DPZA-2: 3 = L3 4 = L5

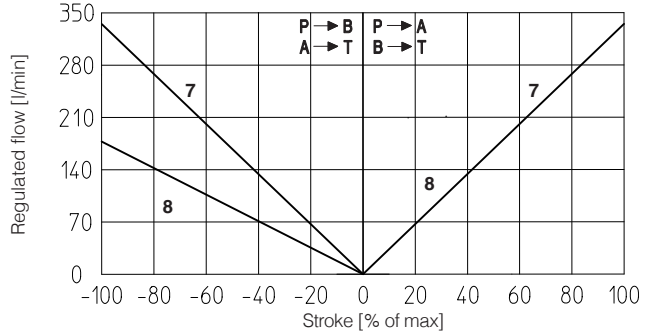

DPZA-4: 7 = L5 8 = DL5

Note: Hydraulic configuration vs. reference signal for configurations 60 and 70 (standard and option /B)

Reference signal $\begin{matrix} 0 \div +10 \text{ V} \\ 12 \div 20 \text{ mA} \end{matrix} \left. \vphantom{\begin{matrix} 0 \div +10 \text{ V} \\ 12 \div 20 \text{ mA} \end{matrix}} \right\} P \rightarrow A / B \rightarrow T$

Reference signal $\begin{matrix} 0 \div -10 \text{ V} \\ 4 \div 12 \text{ mA} \end{matrix} \left. \vphantom{\begin{matrix} 0 \div -10 \text{ V} \\ 4 \div 12 \text{ mA} \end{matrix}} \right\} P \rightarrow B / A \rightarrow T$

19.2 Bode diagrams

Stated at nominal hydraulic conditions.

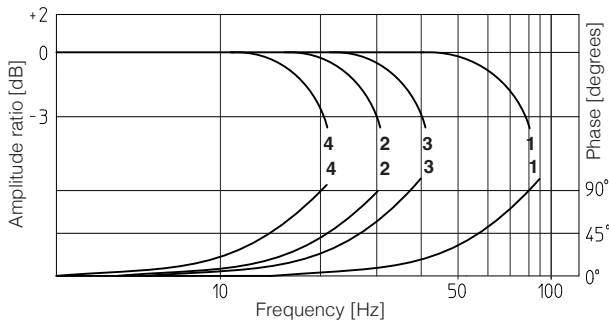

1 = DPZA-1 } $\pm 5\%$ 2 = DPZA-1 } $\pm 100\%$

3 = DPZA-4 } $\pm 5\%$ 4 = DPZA-4 } $\pm 100\%$

19.3 Pressure gain

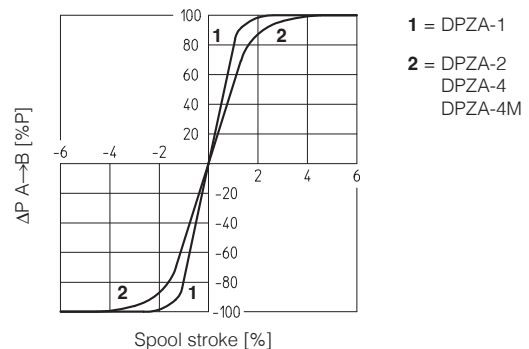
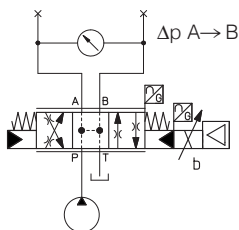

1 = DPZA-1

2 = DPZA-2
DPZA-4
DPZA-4M

20 POWER SUPPLY AND SIGNALS SPECIFICATIONS

Generic electrical output signals of the valve (e.g. fault or monitor signals) must not be directly used to activate safety functions, like to switch-ON/OFF the machine's safety components, as prescribed by the European standards (Safety requirements of fluid technology systems and components-hydraulics, ISO 4413).

20.1 Power supply (V+ and V0)

The power supply must be appropriately stabilized or rectified and filtered: apply at least a 10000 μ F/40 V capacitance to single phase rectifiers or a 4700 μ F/40 V capacitance to three phase rectifiers.

 A safety fuse is required in series to each power supply: 2,5 A time lag fuse.

20.2 Power supply for axis card logic and communication (VL+ and VL0)

The power supply for axis card logic and communication must be appropriately stabilized or rectified and filtered: apply at least a 10000 μ F/40 V capacitance to single phase rectifiers or a 4700 μ F/40 V capacitance to three phase rectifiers.

The separate power supply for controller's logic on pin 3 and 4, allow to remove solenoid power supply from pin 1 and 2 maintaining active the diagnostics, USB and fieldbus communications.

 A safety fuse is required in series to each axis card logic and communication power supply: 500 mA fast fuse.

20.3 Position reference input signal (P_INPUT+)

Functionality of P_INPUT+ signal (pin 10), depends on axis card reference mode, see section 2:

external analog reference (see 2.1): input is used as reference for control in closed loop the actuator position.

Reference input signal is factory preset according to selected valve code, defaults are ± 10 Vdc for standard and $4 \div 20$ mA for /I option.

Input signal can be reconfigured via software selecting between voltage and current, within a maximum range of ± 10 Vdc or ± 20 mA.

external fieldbus reference (see 2.1) or *automatic cycle* (see 2.2): analog reference input signal can be used as on-off commands with input range $0 \div 24$ Vdc.

20.4 Force reference input signal (F_INPUT+) - only for SF, SL

Functionality of F_INPUT+ signal (pin 12), depends on selected axis card reference mode and alternated control options, see section 3:

SF, SL controls and external analog reference selected: input is used as reference for the axis card force closed loop.

Reference input signal is factory preset according to selected valve code, defaults are ± 10 Vdc for standard and $4 \div 20$ mA for /I option.

Input signal can be reconfigured via software selecting between voltage and current, within a maximum range of ± 10 Vdc or ± 20 mA.

SN control or fieldbus/internal reference selected: analog reference input signal can be used as on-off commands with input range $0 \div 24$ Vdc.

20.5 Position monitor output signal (P_MONITOR)

The axis card generates an analog output signal (pin 9) proportional to the actual axis position; the monitor output signal can be software set to show other signals available in the axis card (e.g. analog reference, fieldbus reference, position error, valve spool position).

Monitor output signal is factory preset according to selected valve code, defaults are ± 10 Vdc for standard and $4 \div 20$ mA for /I option.

Output signal can be reconfigured via software selecting between voltage and current, within a maximum range of ± 10 Vdc or ± 20 mA.

20.6 Force monitor output signal (F_MONITOR) - only for SF, SL

The axis card generates an analog output signal (pin 11) according to alternated force control option:

SN control: output signal is proportional to the actual valve spool position

SF, SL controls: output signal is proportional to the actual force applied to the cylinder's rod end

Monitor output signals can be software set to show other signals available in the axis card (e.g. analog reference, force reference).

The output range and polarity are software selectable within the maximum range ± 10 Vdc or ± 20 mA.

Monitor output signal is factory preset according to selected valve code, defaults are ± 10 Vdc for standard and $4 \div 20$ mA for /I option.

Output signal can be reconfigured via software selecting between voltage and current, within a maximum range of ± 10 Vdc or ± 20 mA.

20.7 Enable input signal (ENABLE)

To enable the axis card, a 24Vdc voltage has to be applied on pin 6.

When the Enable signal is set to zero the axis card can be software set to perform one of the following actions:

- maintain the actuator actual position in closed loop control
- move towards a predefined position in closed loop control and maintains the reached position (hold position)
- move forward or backward in open loop (only the valve's closed loop remain active)

20.8 Fault output signal (FAULT)

Fault output signal indicates fault conditions of the axis card (solenoid short circuits/not connected, reference or transducer signal cable broken, maximum error exceeded, etc.). Fault presence corresponds to 0 Vdc, normal working corresponds to 24 Vdc.

Fault status is not affected by the Enable input signal.

Fault output signal can be used as digital output by software selection.

20.9 Position transducer input signal

A position transducer must be always directly connected to the axis card. Select the correct axis card execution depending on the desired transducer interface: digital SSI or Encoder (D execution), potentiometer or a generic transducer with analog interface (A execution).

Position digital input signal is factory preset to binary SSI, it can be reconfigured via software selecting between binary/gray SSI and Encoder.

Position analog input signal is factory preset according to selected valve code, defaults are ± 10 Vdc for standard and $4 \div 20$ mA for /C option.

Input signal can be reconfigured via software selecting between voltage and current, within a maximum range of ± 10 Vdc or ± 20 mA.

Refer to position transducer characteristics to select the transducer type according to specific application requirements (see 21.1).

20.10 Remote pressure/force transducer input signals - only for SF, SL

Analog remote pressure transducers or load cell can be directly connected to the axis card.

Analog input signal is factory preset according to selected valve code, defaults are ± 10 Vdc for standard and $4 \div 20$ mA for /C option.

Input signal can be reconfigured via software selecting between voltage and current, within a maximum range of ± 10 Vdc or ± 20 mA.

Refer to pressure/force transducer characteristics to select the transducer type according to specific application requirements (see 21.2).

21 ACTUATOR'S TRANSDUCER CHARACTERISTICS

21.1 Position transducers

The accuracy of the position control is strongly dependent to the selected position transducer. Four different transducer interfaces are available on the axis cards, depending to the system requirements: potentiometer or analog signal (A execution), SSI or Encoder (D execution). Transducers with digital interface allow high resolution and accurate measures, that combined with fieldbus communication grants highest performances. Transducers with analog interface grant simple and cost effective solutions.

21.2 Pressure/force transducers

The accuracy of the pressure/force control is strongly dependent to the selected pressure/force transducer, see section 3. Alternated force controls require to install pressure transducers or load cell to measure the actual pressure/force values. Pressure transducers allow easy system integration and cost effective solution for alternated position/pressure controls (see tech table **GX800** for pressure transducers details). Load cell transducers allow the user to get high accuracy and precise regulations for alternated position/force control. The characteristics of the remote pressure/force transducers must be always selected to match the application requirements and to obtain the best performances: transducer nominal range should be at least 115%÷120% of the maximum regulated pressure/force.

21.3 Transducers characteristics & interfaces - following values are just for reference, for details please consult the transducer's datasheet

| Execution | Position | | | | Pressure/Force |
|----------------------|---------------|-------------------|------------------------|---------------------|-------------------|
| | A | Analog | D | Incremental Encoder | SF, SL |
| Input type | Potentiometer | Analog | SSI (3) | Incremental Encoder | Analog |
| Power supply (1) | 10 ÷ 30 Vdc | +24 Vdc | +24 Vdc | +5 Vdc / +24 Vdc | +24 Vdc |
| Controller Interface | 0 ÷ 10 V | 0 ÷ 10V 4 ÷ 20 mA | Serial SSI binary/gray | TTL 5Vpp - 150 KHz | ±10 Vdc 4 ÷ 20 mA |
| Max speed | 0,5 m/s | 1 m/s | 1 m/s | 2 m/s | - |
| Max Resolution | < 0.4 % FS | < 0.2 % FS | 5 µm | 1 µm (@ 0.15 m/s) | < 0.4 % FS |
| Linearity error (2) | ± 0.1% FS | < ±0.02% FS | < ± 0.02 % FS | < ± 0.001 % FS | < ±0.25% FS |
| Repeatability (2) | ± 0.05% FS | < ± 0.005% FS | < ± 0.005 % FS | < ± 0.001 % FS | < ±0.1% FS |

(1) Power supply provided by Atos axis card (2) Percentage of total stroke (3) For Balluff BTL7 with SSI interface only special code SA433 is supported

22 TERMINAL BOARD OVERVIEW

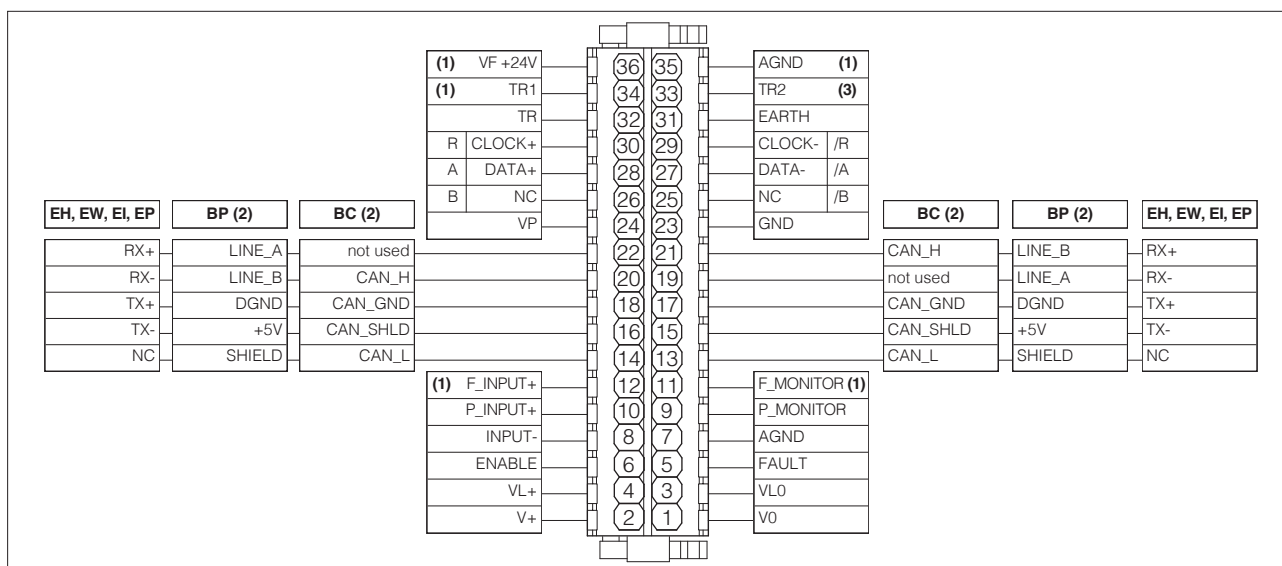

(1) Connections available only for **SF, SL**

(2) For BC and BP executions the fieldbus connections have an internal pass-through connection

(3) Connection available only for **SF**

23 ELECTRONIC CONNECTIONS

23.1 Main connections signals

| CABLE ENTRANCE | PIN | SIGNAL | TECHNICAL SPECIFICATIONS | NOTES |
|----------------|--------------|---|---|--|
| A | 1 | V0 | Power supply 0 Vdc | Gnd - power supply |
| | 2 | V+ | Power supply 24 Vdc | Input - power supply |
| | 3 | VL0 | Power supply 0 Vdc for axis card logic and communication | Gnd - power supply |
| | 4 | VL+ | Power supply 24 Vdc for axis card logic and communication | Input - power supply |
| | 5 | FAULT | Fault (0 Vdc) or normal working (24 Vdc), referred to VL0 | Output - on/off signal |
| | 6 | ENABLE | Enable (24 Vdc) or disable (0 Vdc) the driver, referred to VL0 | Input - on/off signal |
| | 7 | AGND | Analog ground | Gnd - analog signal |
| | 8 | INPUT- | Negative reference input signal for P_INPUT+ and F_INPUT+ | Input - analog signal |
| | 9 | P_MONITOR | Position monitor output signal: ± 10 Vdc / ± 20 mA maximum range, referred to AGND Defaults are: ± 10 Vdc for standard and $4 \div 20$ mA for /I option | Output - analog signal Software selectable |
| | 10 | P_INPUT+ | Position reference input signal: ± 10 Vdc / ± 20 mA maximum range Defaults are: ± 10 Vdc for standard and $4 \div 20$ mA for /I option | Input - analog signal Software selectable |
| | 11 | F_MONITOR | Force (SF, SL controls) or valve spool position (SN control) monitor output signal: ± 10 Vdc / ± 20 mA maximum range, referred to AGND Defaults are: ± 10 Vdc for standard and $4 \div 20$ mA for /I option | Output - analog signal Software selectable |
| | 12 | F_INPUT+ | Force reference input signal (SF, SL controls): ± 10 Vdc / ± 20 mA max. range Defaults are: ± 10 Vdc for standard and $4 \div 20$ mA for /I option | Input - analog signal Software selectable |
| 31 | EARTH | Internally connected to axis card housing | | |

23.2 USB connector - M12 - 5 pin always present

| CABLE ENTRANCE | PIN | SIGNAL | TECHNICAL SPECIFICATIONS | Axis card view | |
|----------------|-----|----------------|--------------------------|-----------------|--|
| B | 1 | +5V_USB | Power supply | <p>(female)</p> | |
| | 2 | ID | Identification | | |
| | 3 | GND_USB | Signal zero data line | | |
| | 4 | D- | Data line - | | |
| | 5 | D+ | Data line + | | |

23.3 BC fieldbus execution connections

| CABLE ENTRANCE | PIN | SIGNAL | TECHNICAL SPECIFICATIONS |
|----------------|-----|-----------------|------------------------------------|
| C1 | 14 | CAN_L | Bus line (low) |
| | 16 | CAN_SHLD | Shield |
| | 18 | CAN_GND | Signal zero data line |
| | 20 | CAN_H | Bus line (high) |
| | 22 | not used | Pass-through connection (1) |

| CABLE ENTRANCE | PIN | SIGNAL | TECHNICAL SPECIFICATIONS |
|----------------|-----|-----------------|------------------------------------|
| C2 | 13 | CAN_L | Bus line (low) |
| | 15 | CAN_SHLD | Shield |
| | 17 | CAN_GND | Signal zero data line |
| | 19 | not used | Pass-through connection (1) |
| | 21 | CAN_H | Bus line (high) |

(1) Pin 19 and 22 can be fed with external +5V supply of CAN interface

23.4 BP fieldbus execution connections

| CABLE ENTRANCE | PIN | SIGNAL | TECHNICAL SPECIFICATIONS |
|----------------|-----|---------------|---------------------------------------|
| C1 | 14 | SHIELD | |
| | 16 | +5V | Power supply |
| | 18 | DGND | Data line and termination signal zero |
| | 20 | LINE_B | Bus line (low) |
| | 22 | LINE_A | Bus line (high) |

| CABLE ENTRANCE | PIN | SIGNAL | TECHNICAL SPECIFICATIONS |
|----------------|-----|---------------|---------------------------------------|
| C2 | 13 | SHIELD | |
| | 15 | +5V | Power supply |
| | 17 | DGND | Data line and termination signal zero |
| | 19 | LINE_A | Bus line (high) |
| | 21 | LINE_B | Bus line (low) |

23.5 EH, EW, EI, EP fieldbus execution connections

| CABLE ENTRANCE | PIN | SIGNAL | TECHNICAL SPECIFICATIONS |
|----------------------|-----|------------|--------------------------|
| C1 (input) | 14 | NC | do not connect |
| | 16 | TX- | Transmitter |
| | 18 | TX+ | Transmitter |
| | 20 | RX- | Receiver |
| | 22 | RX+ | Receiver |

| CABLE ENTRANCE | PIN | SIGNAL | TECHNICAL SPECIFICATIONS |
|-----------------------|-----|------------|--------------------------|
| C2 (output) | 13 | NC | do not connect |
| | 15 | TX- | Transmitter |
| | 17 | TX+ | Transmitter |
| | 19 | RX- | Receiver |
| | 21 | RX+ | Receiver |

23.6 Remote pressure transducer connections - only for SF, SL

| CABLE ENTRANCES | PIN | SIGNAL | TECHNICAL SPECIFICATIONS | NOTES | SL - Single transducer | | SF - Double transducers | |
|-----------------|-----|----------------|---|---|------------------------|---------|-------------------------|---------|
| | | | | | Voltage | Current | Voltage | Current |
| D1 | 33 | TR2 | 2nd signal transducer ± 10 Vdc / ± 20 mA maximum range | Input - analog signal Software selectable | / | / | Connect | Connect |
| | 34 | TR1 | 1st signal transducer ± 10 Vdc / ± 20 mA maximum range | Input - analog signal Software selectable | Connect | Connect | Connect | Connect |
| D2 | 35 | AGND | Common gnd for transducer power and signals | Common gnd | Connect | / | Connect | / |
| | 36 | VF +24V | Power supply +24Vdc | Output - power supply | Connect | Connect | Connect | Connect |

E-ATRA remote pressure transducer connection - see tech table GX800

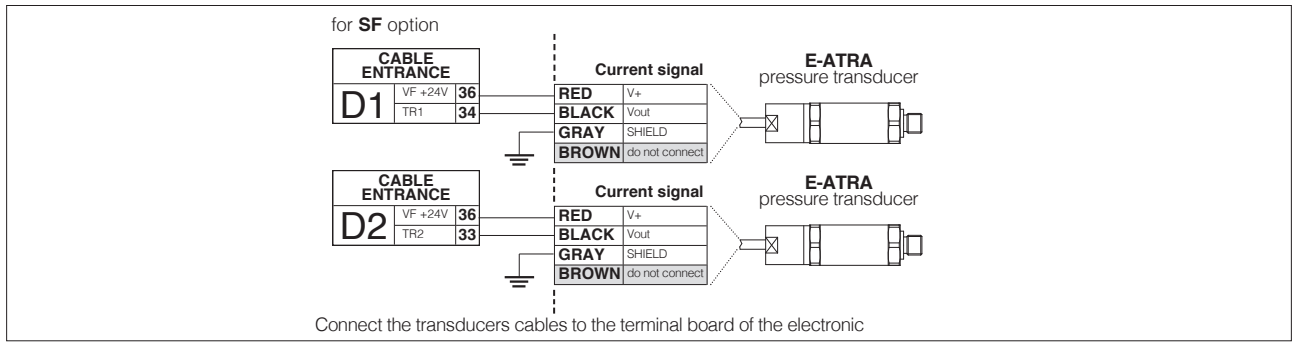

23.7 D execution - Digital position transducers connections

| CABLE ENTRANCE | PIN | SSI - default transducer (1) | | | Encoder (1) | | |
|----------------|-----|---|--|---|---|--|---|
| | | SIGNAL | TECHNICAL SPECIFICATION | NOTES | SIGNAL | TECHNICAL SPECIFICATION | NOTES |
| E | 30 | CLOCK+ | Serial synchronous clock (+) | Input - digital signal | R | Input channel R | Input - digital signal |
| | 29 | CLOCK- | Serial synchronous clock (-) | | /R | Input channel /R | |
| | 28 | DATA+ | Serial position data (+) | | A | Input channel A | |
| | 27 | DATA- | Serial position data (-) | | /A | Input channel /A | |
| | 26 | NC | Not connect | Do not connect | B | Input channel B | |
| | 25 | NC | Not connect | Do not connect | /B | Input channel /B | |
| | 24 | VP | Power supply: +24Vdc, +5Vdc or OFF (default OFF) | Output - power supply Software selectable | VP | Power supply: +24Vdc, +5Vdc or OFF (default OFF) | Output - power supply Software selectable |
| 23 | GND | Common gnd for transducer power and signals | Common gnd | GND | Common gnd for transducer power and signals | Common gnd | |

(1) Digital position transducer type is software selectable: Encoder or SSI, see 20.9

SSI connection - example

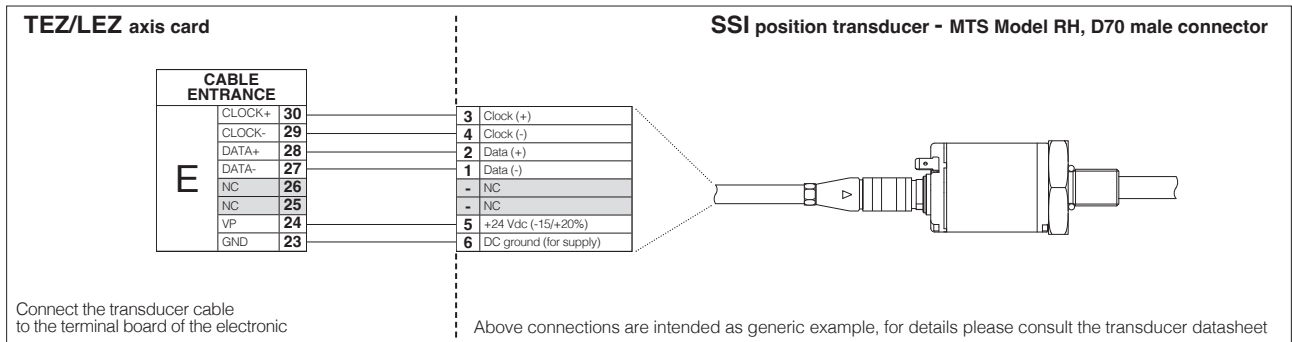

Encoder connection - example

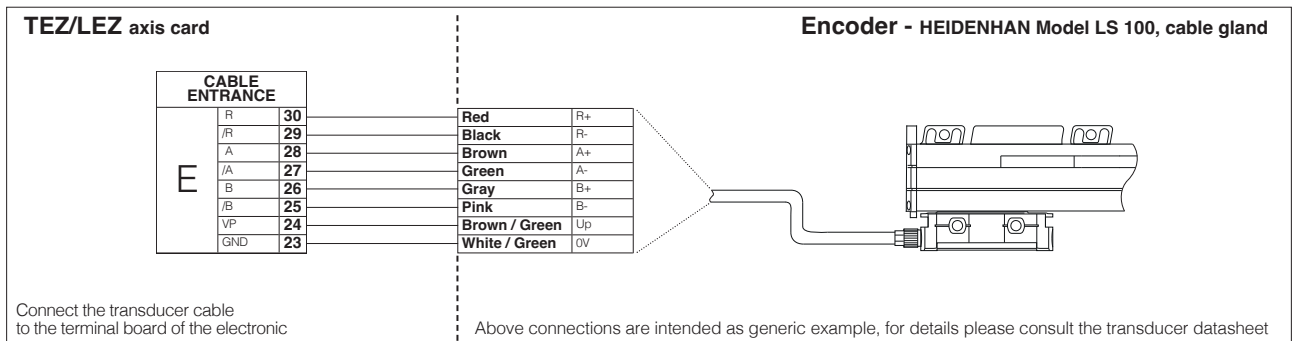

23.8 A execution - Analog position transducers connector

| CABLE ENTRANCE | PIN | SIGNAL | TECHNICAL SPECIFICATION | NOTES |
|----------------|-----|--------|---|---|
| E | 32 | TR | Signal transducer | Input - analog signal |
| | 24 | VP | Power supply: +24Vdc or OFF (default OFF) | Output - power supply Software selectable |
| | 23 | GND | Common gnd for transducer power and signals | Common gnd |

CABLE ENTRANCE OVERVIEW

Cables entrance description:

- (A) main connections
- (B) USB connector always present (factory plugged)
- (C1) fieldbus (input)
- (C2) fieldbus (output)
- (D1) pressure/force transducer 1
- (D2) pressure transducer 2 (factory plugged)
- (E) position transducer
- (P) threaded plug

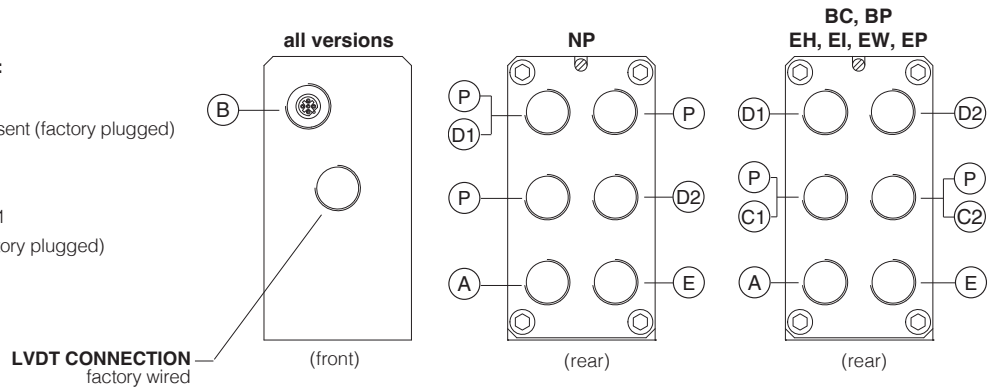

TERMINAL BOARD AND FIELDBUS TERMINATOR

Remove the 4 screws of axis card rear cover to access terminal board and fieldbus terminator

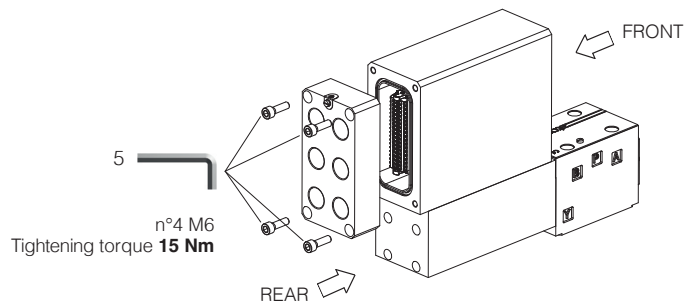

WARNING: the above operation must be performed in a safety area

Terminal board - see section 22

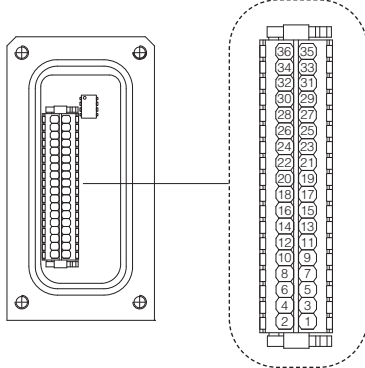

Fieldbus terminator only for BC and BP executions (1)

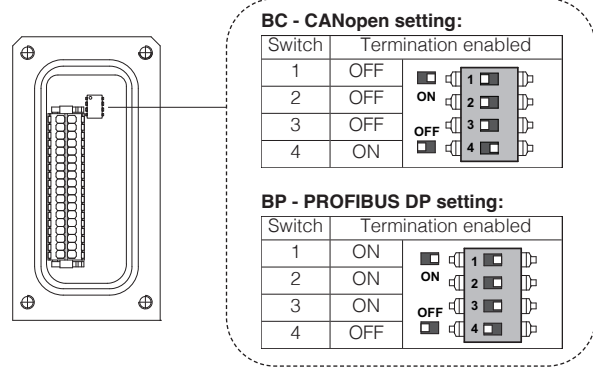

BLUETOOTH ADAPTER AND USB CONNECTOR

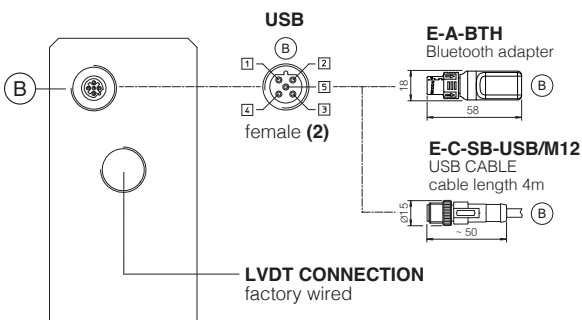

METALLIC PROTECTION CAP - supplied with the valves

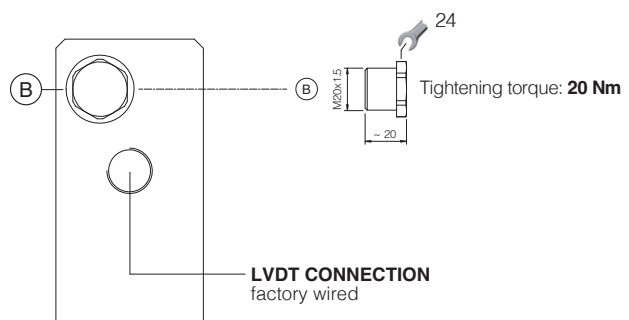

(1) On-board digital driver + axis card with BC and BP fieldbus interface are delivered by default 'Not Terminated'. All switches are set OFF
 (2) Pin layout always referred to on-board digital driver + axis card view

24.1 Cable glands and threaded plug for LEZ-SN - see tech table **KX800**

| Communication interfaces | To be ordered separately | | | | Cable entrance overview | Notes |
|--|--------------------------|------------------|------------------------|----------|-------------------------|--|
| | Cable gland quantity | entrance | Threaded plug quantity | entrance | | |
| NP | 2 | A - E | none | none | | Cable entrance A, E are open for costumers Cable entrance P are factory plugged |
| BC, BP, EH, EW, EI, EP "via stub" connection | 3 | C1 A - E | 1 | C2 | | Cable entrance A, E, C1, C2 are open for costumers Cable entrance P are factory plugged |
| BC, BP, EH, EW, EI, EP "daisy chain" connection | 4 | C1 - C2 A - E | none | none | | Cable entrance A, E, C1, C2 are open for costumers Cable entrance P are factory plugged |

24.2 Cable glands and threaded plug for LEZ-SF, SL - see tech table **KX800**

| Communication interfaces | To be ordered separately | | | | Cable entrance overview | Notes |
|--|--------------------------|-----------------------------|------------------------|----------|-------------------------|---|
| | Cable gland quantity | entrance | Threaded plug quantity | entrance | | |
| NP | 4 (SF) 3 (SL) | D1 D2 A - E | none | none | | Cable entrance A, E, D1 are open for costumers Cable entrance P, D2 are factory plugged (1) |
| BC, BP, EH, EW, EI, EP "via stub" connection | 5 (SF) 4 (SL) | D1 - D2 C1 A - E | 1 | C2 | | Cable entrance A, E, C1, C2, D1 are open for costumers Cable entrance D2 is factory plugged (1) |
| BC, BP, EH, EW, EI, EP "daisy chain" connection | 6 (SF) 5 (SL) | D1 - D2 C1 - C2 A - E | none | none | | Cable entrance A, E, C1, C2, D1, D2 are open for costumers Cable entrance D2 is factory plugged (1) |

(1) Remove plug D2 for second transducer connection of SF version

25 MAIN SOFTWARE PARAMETER SETTINGS

For a detailed descriptions of the available settings, wirings and installation procedures, please refer to the user manuals included in the Z-SW-SETUP programming software:

Z-MAN-RA-LEZ - user manual for **TEZ** and **LEZ** with **SN**

Z-MAN-RA-LEZ-S - user manual for **TEZ** and **LEZ** with **SF, SL**

25.1 External reference and transducer parameters

Allow to configure the axis card reference and transducer inputs, analog or digital, to match the specific application requirements:

- *Scaling parameters* define the correspondence of these signals with the specific actuator stroke or force to be controlled
- *Limit parameters* define maximum/minimum stroke and force to detect possible alarm conditions
- *Homing parameters* define the startup procedure to initialize incremental transducer (e.g. Encoder)

25.2 PID control dynamics parameters

Allow to optimize and adapt the axis card closed loop to the wide range of hydraulic system characteristics:

- *PID parameters* each part of the closed loop algorithm (proportional, integral, derivative, feed forward, fine positioning, etc) can be modified to match the application requirements

25.3 Monitoring parameters

Allow to configure the axis card monitoring function of the positioning error (difference between actual reference and feedback) and detects anomalous conditions:

- *Monitoring parameters* maximum allowed errors can be set for both static and dynamic positioning phases, and dedicated waiting times can be set to delay the activation of the alarm condition and relevant reaction (see 25.4)

25.4 Fault parameters

Allow to configure how the axis card detects and reacts to alarm conditions:

- *Diagnostics parameters* define different conditions, threshold and delay time to detect alarm conditions
- *Reaction parameters* define different actions to be performed in case of alarm presence (stop at actual or preprogrammed position, emergency forward/backward, axis card disabling, etc.)

25.5 Valve characteristics compensation

Allow to modify the valve regulation to match the actuator/system characteristics and to obtain the best overall performances:

- *Valve parameters* modify the standard valve regulation by means of deadband compensation, curve linearization and differentiated gain for positive and negative regulation

25.6 Motion phases parameters

When the internal reference generation is active a pre-programmed cycle can be generated; start/stop/switch-over commands and reference generation types parameters can be set to design a customized sequence of motion phases adapted to the specific application requirements (see 2.2).

26 PLUGS LOCATION FOR PILOT/DRAIN CHANNELS

Depending on the position of internal plugs, different pilot/drain configurations can be obtained as shown below. To modify the pilot/drain configuration, proper plugs must only be interchanged. The plugs have to be sealed using loctite 270. Standard valves configuration provides internal pilot and external drain.

| | | | |
|--------|----------------|----------------|---|
| DPZA-1 | Pilot channels | Drain channels | <p>Internal piloting: blinded plug SP-X300F ① in X; External piloting: blinded plug SP-X300F ② in Pp; Internal drain: blinded plug SP-X300F ③ in Y; External drain: blinded plug SP-X300F ④ in Dr.</p> |
| DPZA-2 | Pilot channels | Drain channels | <p>Internal piloting: Without blinded plug SP-X300F ①; External piloting: Add blinded plug SP-X300F ①; Internal drain: Without blinded plug SP-X300F ②; External drain: Add blinded plug SP-X300F ②.</p> |
| DPZA-4 | Pilot channels | Drain channels | <p>Internal piloting: Without blinded plug SP-X500F ①; External piloting: Add blinded plug SP-X500F ①; Internal drain: Without blinded plug SP-X300F ②; External drain: Add blinded plug SP-X300F ②.</p> |

27 FASTENING BOLTS AND SEALS

| Type | Size | Fastening bolts | Seals |
|------|---------|---|---|
| DPZA | 1 = 10 | 4 socket head screws M6x40 class 12.9 Tightening torque = 15 Nm | 5 OR 2050; Diameter of ports A, B, P, T: Ø 11 mm (max) 2 OR 108 Diameter of ports X, Y: Ø = 5 mm (max) |
| | 2 = 16 | 4 socket head screws M10x50 class 12.9 Tightening torque = 70 Nm 2 socket head screws M6x45 class 12.9 Tightening torque = 15 Nm | 4 OR 130; Diameter of ports A, B, P, T: Ø 20 mm (max) 2 OR 2043 Diameter of ports X, Y: Ø = 7 mm (max) |
| | 4 = 25 | 6 socket head screws M12x60 class 12.9 Tightening torque = 125 Nm | 4 OR 4112; Diameter of ports A, B, P, T: Ø 24 mm (max) 2 OR 3056 Diameter of ports X, Y: Ø = 7 mm (max) |
| | 4M = 27 | 6 socket head screws M12x60 class 12.9 Tightening torque = 125 Nm | 4 OR 41301; Diameter of ports A, B, P, T: Ø 32 mm (max) 2 OR 3056 Diameter of ports X, Y: Ø = 7 mm (max) |

DPZA-LEZ-*-1

ISO 4401: 2005

Mounting surface: 4401-05-05-0-05

(see table P005)

| Mass [kg] | |
|------------|------|
| DPZA-*-17* | 13,7 |
| Option /G | +0,9 |

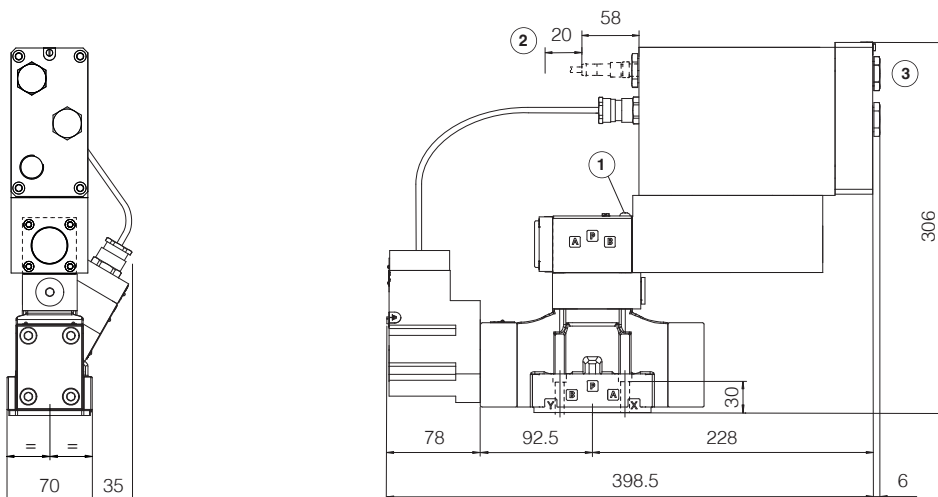

DPZA-LEZ-*-2

ISO 4401: 2005

Mounting surface: 4401-07-07-0-05

(see table P005)

| Mass [kg] | |
|------------|------|
| DPZA-*-27* | 17,9 |
| Option /G | +0,9 |

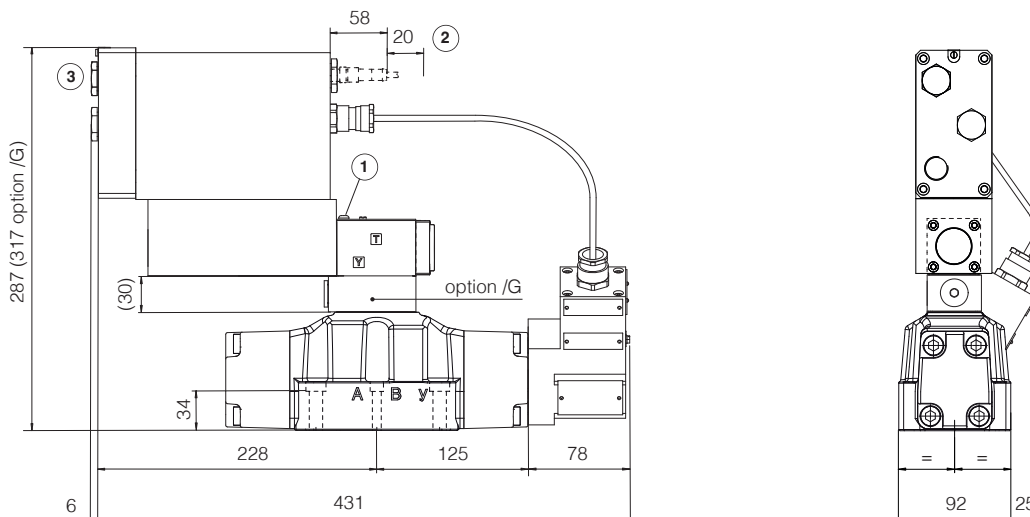

- ① = Air bleeding
- ② = Space required for connection cable and for Bluetooth adapter or USB connector removal
- ③ = The dimensions of cable glands must be considered (see tech table **KX800**)

Note: for option /B the proportional solenoid, the LVDT transducer and the on-board digital driver + axis card are at side of port A (side B of pilot valve)

DPZA-LEZ-*-4 DPZA-LEZ-*-4M

ISO 4401: 2005

Mounting surface: 4401-08-08-0-05
(see table P005)

| Mass [kg] | |
|------------|------|
| DPZA-*-4* | 23,1 |
| DPZA-*-4M* | 23,1 |
| Option /G | +0,9 |

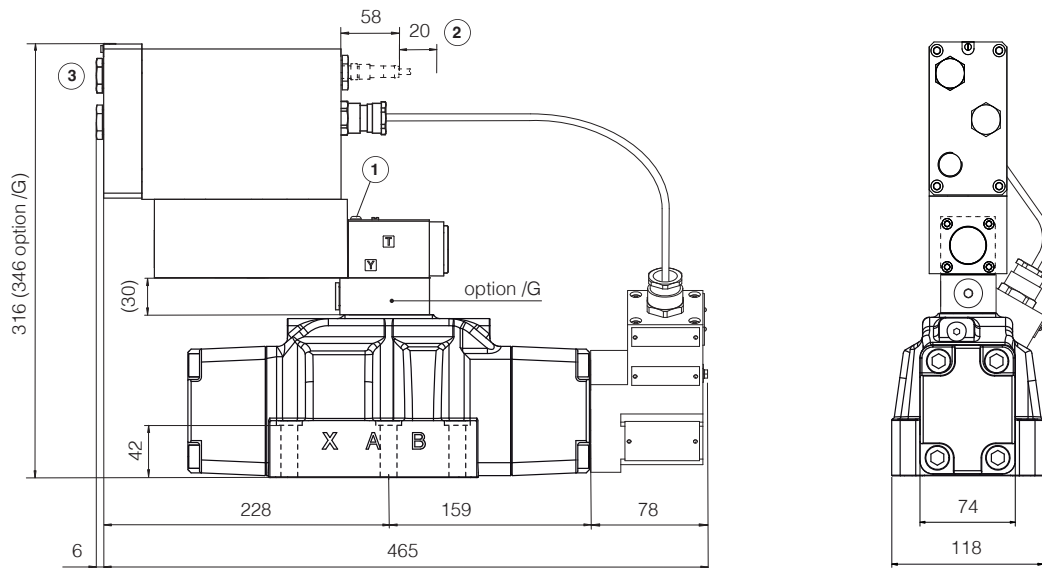

- ① = Air bleeding
- ② = Space required for connection cable and for Bluetooth adapter or USB connector removal
- ③ = The dimensions of cable glands must be considered (see tech table **KX800**)

Note: for option /B the proportional solenoid, the LVDT transducer and the on-board digital driver + axis card are at side of port A (side B of pilot valve)

29 RELATED DOCUMENTATION

X010 Basics for electrohydraulics in hazardous environments
X020 Summary of Atos ex-proof components certified to ATEX, IECEx, EAC, PESO, CCC
FX500 Ex-proof digital proportionals with p/Q control
FX900 Operating and maintenance information for ex-proof proportional valves
GS500 Programming tools
GS510 Fieldbus

GX800 Ex-proof pressure transducer type E-ATRA-7
KX800 Cable glands for ex-proof valves
P005 Mounting surfaces for electrohydraulic valves
Z-MAN-RA-LEZ TEZ/LEZ user manual
Z-MAN-RA-LEZ-S TEZ/LEZ with p/Q control user manual